

**CHM WORM GEARED  
MOTORS  
AND WORM GEAR UNITS**



**ACCESSORIES FOR GEAR BOXES  
AND ELECTRIC MOTORS**



## INDEX

CHM – CHMR – CHME – CHMRE Worm geared motors and worm gear units	Page	1
Introduction	Page	2
CHM – CHMR – CHME – CHMRE Models – order example	Page	3
CHM Motor mounting flanges	Page	4
Mounting positions	Page	5
Performance and dimensions with CHM 025 4-pole motors	Page	6
Performance CHM 30 – 130 with 4-pole motors	Page	7
CHM – CHMR – CHME – CHMRE 030 – 130 Dimensions	Pages	8-9
CHTPC / CHM – CHME Worm gears with pre-stage modules	Page	10
CHTPC / CHM – CHME Possible couplings and assembly instructions	Page	11
Performance CHTPC / CHM with 4-pole motors	Page	12
CHTPC / CHM Dimensions	Page	13
Combined worm gears	CHM / CHM – CHME CHMR / CHM – CHME	Pages 14-15
Executions	CHM / CHM – CHME CHMR / CHM – CHME	Page 16
Performance CHM / CHM with 4-pole motors	Page	17
Combined gear dimensions	Page	18
Torque arm kit – Single and double output shaft	Page	19
Cover	Page	20
BRM-S and BRM-D Reduction bushings kit	Page	20
Technical data for CHT electric motors	Page	21
Sizes and overall dimensions of CHT electric motors	Page	21
Forced ventilation kit	Page	22
Exploded view and spare parts list for worm gears	Page	23
Use and maintenance instructions	Page	24
General sales conditions	Page	25

# WORM GEARED MOTORS AND WORM GEAR UNITS



CHM



CHME



CHMR



CHMRE

 **CHIARAVALLI**  
TRASMISSIONI S.p.A.

## INTRODUCTION

The worm gears made by Chiaravalli Trasmissioni SpA are square and are considerably versatile for mounting. The machining of the components, carried out using numeric control machines, guarantees maximum precision for the restricted tolerances, producing a product that will remain reliable over time. The groups are constructed with aluminium casings from sizes 025 to 090, while the sizes 110 and 130 are made from cast iron.

All of the bodies are painted with RAL 9022 aluminium colour to protect the parts from aging and to give better protection against micro-blowholes that may be present in the aluminium.

The gears are supplied with at least one filling plug that is also used during testing to check for possible leaks. A connection flange allows two gears to be combined in order to obtain high gear ratios.

Four sizes of CHTPC pre-stage gears are available to pair with the gears; these are also constructed in aluminium and are painted like the worm gears.

All of the groups are supplied with a lubricant whose characteristics are described in the following table.

## LUBRICATION

	CHM 025/090	CHM 110/130			CHTPC
<b>Lubricant</b>	Synthetic	Mineral	Mineral	Mineral	Synthetic
<b>°C Ambient</b>	-25°C/+50°C	-25°C/+50°C	-5°C/+40°C	-15°C/+25°C	-25°C/+50°C
<b>ISO</b>	VG320	VG320	VG460	VG220	VG320
<b>AGIP</b>	TELIUM VSF 320	BLASIA 320	BLASIA 460	BLASIA 220	TELIUM VSF 320
<b>SHELL</b>	TIVELA OIL SC 320	OMALA OIL 320	OMALA OIL 460	OMALA OIL 220	TIVELA OIL SC 320
<b>IP</b>	TELIUM VSF	MELLANA OIL 320	MELLANA OIL 460	MELLANA OIL 220	TELIUM VSF

## LUBRICATION

The size 025 to 090 gears are supplied complete with synthetic oil and therefore do not require any maintenance. The size 110 and 130 gears are supplied with the quantity of mineral oil foreseen for the B3 assembly position. It is the client's responsibility to adapt the quantity of oil to the assembly position and in addition, to substitute the filling plug, supplied closed for transport reasons, with the one equipped with a hole attached to the gear. If the breather plug is not installed it may create internal pressure with a consequent leakage of oil from the oil seals. For the sizes 110 and 130 we recommend that the oil is changed after the running in period, approx. 300 working hours.

## QUANTITY OF OIL IN LITRES

CHM	025	030	040	050	063	075	090	110	130	CHTPC	63	71	80	90
<b>B3</b>	0.02	0.04	0.08	0.15	0.30	0.55	1	3	4.5		0.05	0.07	0.15	0.16
<b>B8</b>	0.02	0.04	0.08	0.15	0.30	0.55	1	2.2	3.3		0.05	0.07	0.15	0.16
<b>B6/B7</b>	0.02	0.04	0.08	0.15	0.30	0.55	1	2.5	3.5		0.05	0.07	0.15	0.16
<b>V5</b>	0.02	0.04	0.08	0.15	0.30	0.55	1	3	4.5		0.05	0.07	0.15	0.16
<b>V6</b>	0.02	0.04	0.08	0.15	0.30	0.55	1	2.2	3.3		0.05	0.07	0.15	0.16

## MOTOR MOUNTING FLANGES

Gears that are supplied with mounting flanges must be assembled with motors whose shaft and flange tolerances correspond to a "normal class" of quality in order to avoid vibration and forcing of the input bearing. Motors supplied by Chiaravalli guarantee that this requirement is fulfilled. For ease of consultation, the correspondence of the size of the B5 and B14 motor with the sizes of the shaft and the motor connection flange are shown in the following table.

Remember that, as the motor connection flanges are separate from the body it is also possible to have a shaft / flange combination that does not correspond to the table, e.g. 19/140, thereby offering adaptability for other non-unified models such as the brushless or direct current types.

MMF	056	063	071	080	090	100	112	132
<b>B5</b>	9/120	11/140	14/160	19/200	24/200	28/250	28/250	38/300
<b>B14</b>	9/80	11/90	14/105	19/120	24/140	28/160	28/160	38/200

## MODELS CHM - CHMR - CHME - CHMRE

TYPE (1)	SIZE (2)	VERSION (3)	FLANGE POS. (4)	i	M.M.F.	MOUNT. POS. (4)
<b>CHM</b>	025	FA	1	7.5		U UNIVERSAL
	030	FB	2	10		B3
<b>CHMR</b>	040	FC		15		B8
	050	FD		20		B6
<b>CHME</b>	063	FE		25		B7
	075			30		V5
<b>CHMRE</b>	090			40		V6
	110			50		
	130			60		
				80		
				100		

See page 4

## EXAMPLE ORDER

<b>CHM</b>	<b>090</b>	<b>FA (5)</b>	<b>2 (5)</b>	<b>30</b>	<b>90 B14</b>	<b>V5</b>
------------	------------	---------------	--------------	-----------	---------------	-----------

If the motor is also required, please specify:

Size es. 90 L4

Power es. Kw 1.5

Poles es. 4

Voltage es. V230/400

Frequency es. 50 Hz

Flange es. B 14

N.B. From size 25 to 63 the gears are always supplied in the Universal position and can therefore be mounted in any position, from size 75 to size 130 if the position required differs from B3 it must be specified.

In particular, in the event that a gear in position B3 is to be mounted in positions V5 or V6, the bearing positioned in the upper side must be lubricated using suitable grease that ensures proper lubrication.

We have tested Tecnolubeseal POLYMER 400/2 grease.

1) see page 1

2) see pages 6 and 7

3) see page 9

4) see page 5

5) lack of instructions indicates that the gear is not equipped with an output flange.



# MOTOR MOUNTING FLANGES AVAILABLE

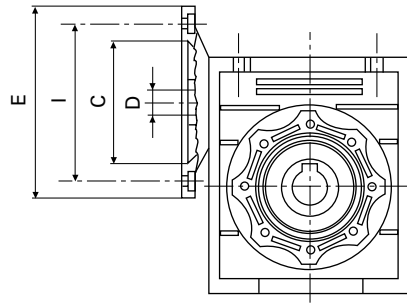

	PAM	C	I	E	7,5	10	15	20	25	30	40	50	60	80	100
					D										
<b>CHM 025</b>	56B14	50	65	80	9	9	9	9	9	9	9	9	9		
<b>CHM 030</b>	63B5	95	115	140											
	63B14	60	75	90	11	11	11	11	11	11	11	11			
	56B5	80	100	120	9	9	9	9	9	9	9	9	9	9	
<b>CHM 040</b>	56B14	50	65	80	9	9	9	9	9	9	9	9	9	9	
	71B5	110	130	160	14	14	14	14	14	14	14				
	71B14	70	85	105	14	14	14	14	14	14	14				
	63B5	95	115	140	11	11	11	11	11	11	11	11	11	11	11
<b>CHM 050</b>	63B14	60	75	90	11	11	11	11	11	11	11	11	11	11	11
	56B5	80	100	120								9	9	9	9
	80B5	130	165	200	19	19	19	19	19	19					
	80B14	80	100	120	19	19	19	19	19	19					
<b>CHM 063</b>	71B5	110	130	160											
	71B14	70	85	105											
	90B5	130	165	200	24	24	24	24	24	24					
	90B14	95	115	140	24	24	24	24	24	24					
	80B5	130	165	200	19	19	19	19	19	19	19	19	19		
	80B14	80	100	120	19	19	19	19	19	19	19	19	19		
<b>CHM 075</b>	71B5	110	130	160								14	14	14	14
	71B14	70	85	105							14	14	14	14	14
	100/112B5	180	215	250	28	28	28								
	100/112B14	110	130	160	28	28	28								
	90B5	130	165	200	24	24	24	24	24	24	24				
	90B14	95	115	140	24	24	24	24	24	24	24	24	24		
<b>CHM 090</b>	80B5	130	165	200				19	19	19	19	19	19	19	19
	80B14	80	100	120				19	19	19	19	19	19	19	19
	71B5	110	130	160							14	14	14	14	14
	71B14	70	85	105							14	14	14	14	14
<b>CHM 110</b>	100/112B5	180	215	250	28	28	28	28	28	28					
	100/112B14	110	130	160	28	28	28	28	28	28					
	90B5	130	165	200	24	24	24	24	24	24	24	24	24		
	90B14	95	115	140	24	24	24	24	24	24	24	24	24		
	80B5	130	165	200							19	19	19	19	19
<b>CHM 130</b>	80B14	80	100	120							19	19	19	19	19
	132B5	230	265	300	38	38	38	38							
	100/112B5	180	215	250	28	28	28	28	28	28	28	28	28		
	100/112B14	110	130	160	28	28	28	28	28	28	28	28	28	28	
<b>CHM 130</b>	90B5	130	165	200					24	24	24	24	24	24	24
	100/112B5	180	215	250					28	28	28	28	28	28	28
	100/112B14	110	130	160					28	28	28	28	28	28	28
<b>CHM 130</b>	90B5	130	165	200										24	24

# MOUNTING POSITION

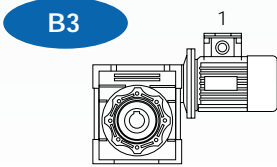
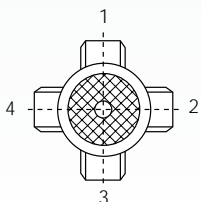
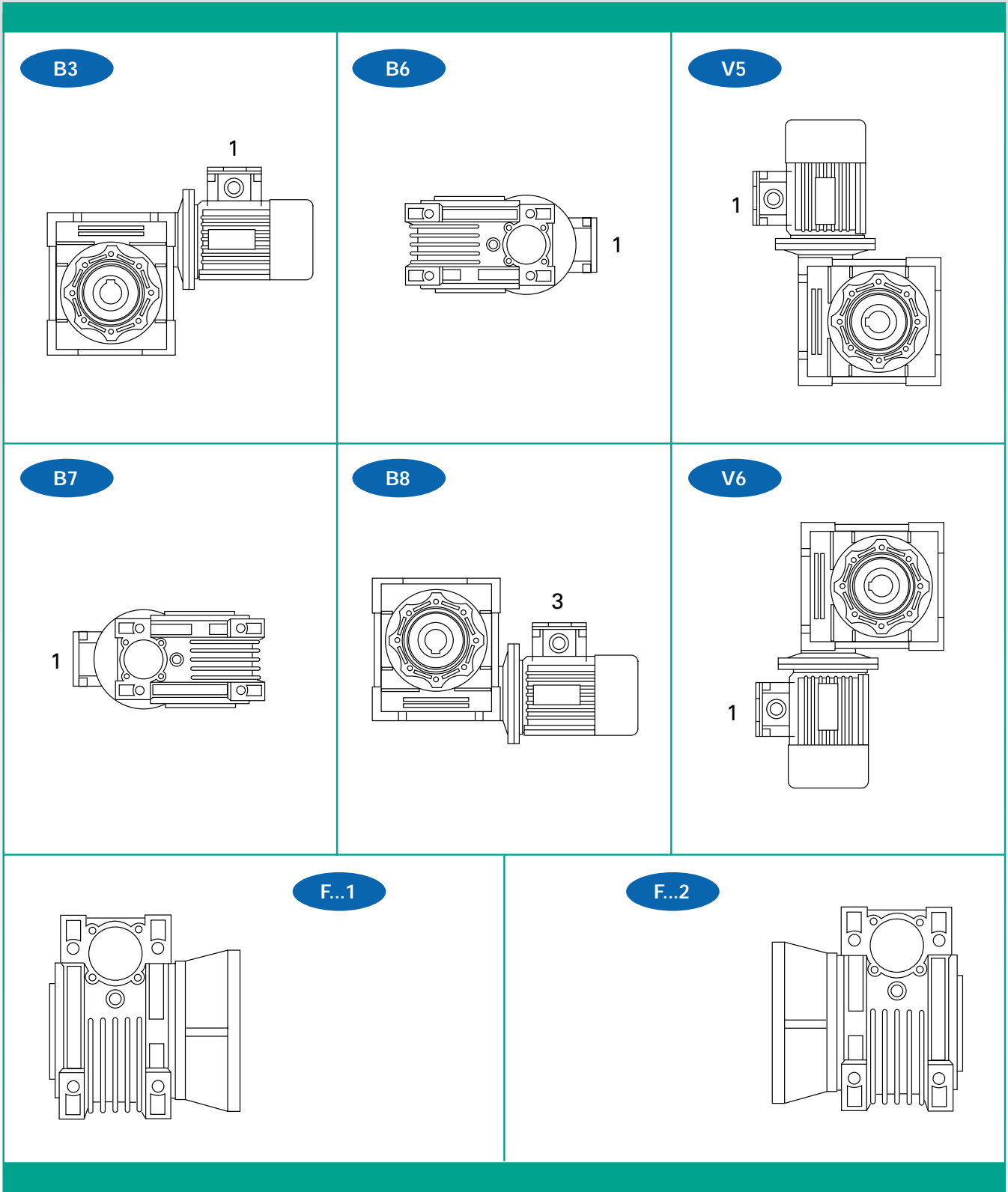

**POSITION OF TERMINAL BOX**

N.B. The position of the terminal box always refers to the B3 position.



# CHM 025 PERFORMANCE WITH 4-POLE MOTORS – 1400 REVS. INPUT

TYPE	i=ratio	n2 r/min	Kw=P1	Nm=T2	f.s.
CHM 025	7.5	186.7	0.09	3.8	2.8
	10	140.0	0.09	5	2.4
	15	93.3	0.09	7.2	1.6
	20	70.0	0.09	9	1.3
	25	56.0	0.09	10	1.0
	30	46.7	0.09	12.3	1.1
	40	35.0	0.09	13	1.0
	50	28.0	0.09	14	0.7
60	23.3	0.09	14	0.6	

## CHM 025 DIMENSIONS

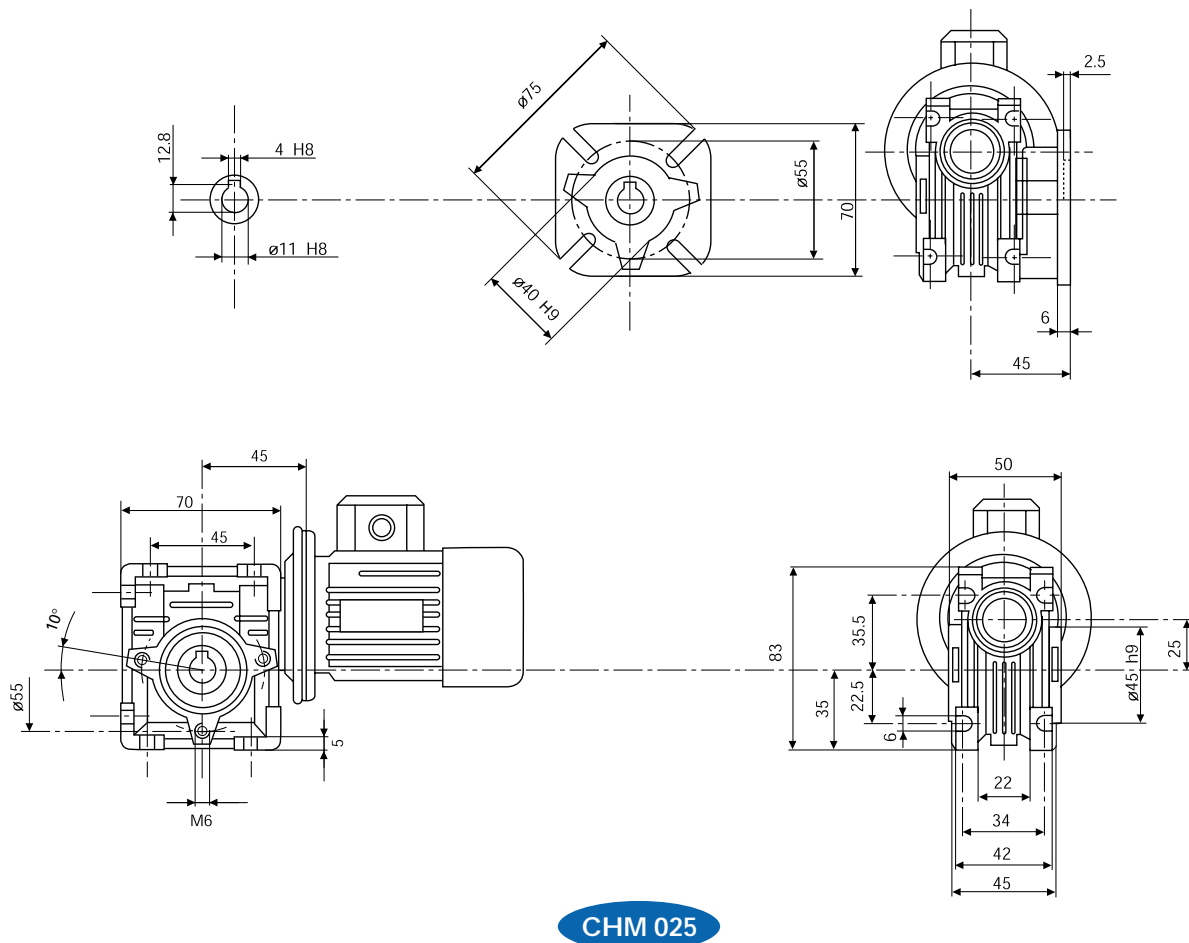

Weight 0.7 Kg. excluding motor

## CHM PERFORMANCE WITH 4-POLE MOTORS – 1400 REVS. INPUT

TYPE	i=ratio	n2 r/min	Kw=P1	Nm=T2	f.s.
	7.5	186.7	0.22	9	2.1
	10	140.0	0.22	11	1.6
	15	93.3	0.22	16	1.0
	20	70.0	0.22	20	0.9
<b>CHM 030</b>	25	56.0	0.18	20	1.0
	30	46.7	0.18	22	0.9
	40	35.0	0.18	21	0.8
	50	28.0	0.18	19	0.8
	60	23.3	0.09	18	0.9
	80	17.5	0.09	13	0.9

TYPE	i=ratio	n2 r/min	Kw=P1	Nm=T2	f.s.
	7.5	186.7	4.00	180	1.0
	10	140.0	4.00	237	0.8
	15	93.3	3.00	260	0.8
	20	70.0	1.50	167	1.2
<b>CHM 075</b>	25	56.0	1.50	204	1.0
	30	46.7	1.50	232	1.0
	40	35.0	1.10	214	1.0
	50	28.0	0.75	176	1.2
	60	23.3	0.75	199	1.0
	80	17.5	0.55	178	1.1
	100	14.0	0.55	203	0.9

TYPE	i=ratio	n2 r/min	Kw=P1	Nm=T2	f.s.
	7.5	186.7	0.55*	22	1.6
	10	140.0	0.55*	30	1.4
	15	93.3	0.55*	44	0.9
	20	70.0	0.55*	38	1.0
<b>CHM 040</b>	25	56.0	0.37	45	0.9
	30	46.7	0.37	52	0.8
	40	35.0	0.25	43	0.9
	50	28.0	0.22	44	0.9
	60	23.3	0.18	42	0.8
	80	17.5	0.18	36	0.8
	100	14.0	0.18	35	0.8

TYPE	i=ratio	n2 r/min	Kw=P1	Nm=T2	f.s.
	7.5	186.7	4.00	184	1.5
	10	140.0	4.00	242	1.3
	15	93.3	4.00	351	1.1
	20	70.0	4.00	456	0.8
<b>CHM 090</b>	25	56.0	3.00	417	0.8
	30	46.7	3.00	478	0.9
	40	35.0	1.50	306	1.2
	50	28.0	1.50	367	1.0
	60	23.3	1.50	421	0.8
	80	17.5	0.75	257	1.1
	100	14.0	0.75	300	0.9

TYPE	i=ratio	n2 r/min	Kw=P1	Nm=T2	f.s.
	7.5	186.7	0.75	33.3	2.0
	10	140.0	0.75	43.9	1.6
	15	93.3	0.75	62.6	1.2
	20	70.0	0.75	80	0.9
<b>CHM 050</b>	25	56.0	0.55	70	1.0
	30	46.7	0.55	80	1.0
	40	35.0	0.37	67	1.1
	50	28.0	0.37	78	0.9
	60	23.3	0.37	87	0.8
	80	17.5	0.25	70	0.9
	100	14.0	0.18	59	0.9

TYPE	i=ratio	n2 r/min	Kw=P1	Nm=T2	f.s.
	7.5	186.7	7.50	344	1.6
	10	140.0	7.50	453	1.3
	15	93.3	7.50	659	1.0
	20	70.0	5.50	635	1.0
<b>CHM 110</b>	25	56.0	4.00	573	1.2
	30	46.7	4.00	645	1.1
	40	35.0	3.00	636	1.1
	50	28.0	3.00	764	0.9
	60	23.3	2.20	645	1.0
	80	17.5	1.50	546	0.9
	100	14.0	1.10	470	1.0

TYPE	i=ratio	n2 r/min	Kw=P1	Nm=T2	f.s.
	7.5	186.7	1.50	67.4	1.8
	10	140.0	1.50	88.6	1.4
	15	93.3	1.50	126	1.1
	20	70.0	1.50	164	0.8
<b>CHM 063</b>	25	56.0	1.10	145	0.9
	30	46.7	1.10	165	1.0
	40	35.0	0.75	143	1.0
	50	28.0	0.55	122	1.1
	60	23.3	0.55	138	0.9
	80	17.5	0.37	114	1.1
	100	14.0	0.37	127	0.9

TYPE	i=ratio	n2 r/min	Kw=P1	Nm=T2	f.s.
	7.5	186.7	7.50	348	2.2
	10	140.0	7.50	455	1.8
	15	93.3	7.50	660	1.2
	20	70.0	7.50	877	1.0
<b>CHM 130</b>	25	56.0	7.50	1071	0.9
	30	46.7	7.50	1225	0.8
	40	35.0	5.50	1173	0.9
	50	28.0	4.00	1023	0.9
	60	23.3	3.00	886	1.1
	80	17.5	3.00	1112	0.8
	100	14.0	1.50	652	1.1

It is also possible to couple motors that are less powerful than those shown in the table. It is possible to couple 2800 or 900 rev. motors by adapting the power and verifying the application. For any clarification, please contact our technical office.

# CHM - CHMR - CHME - CHMRE 030 ÷ 130 DIMENSIONS

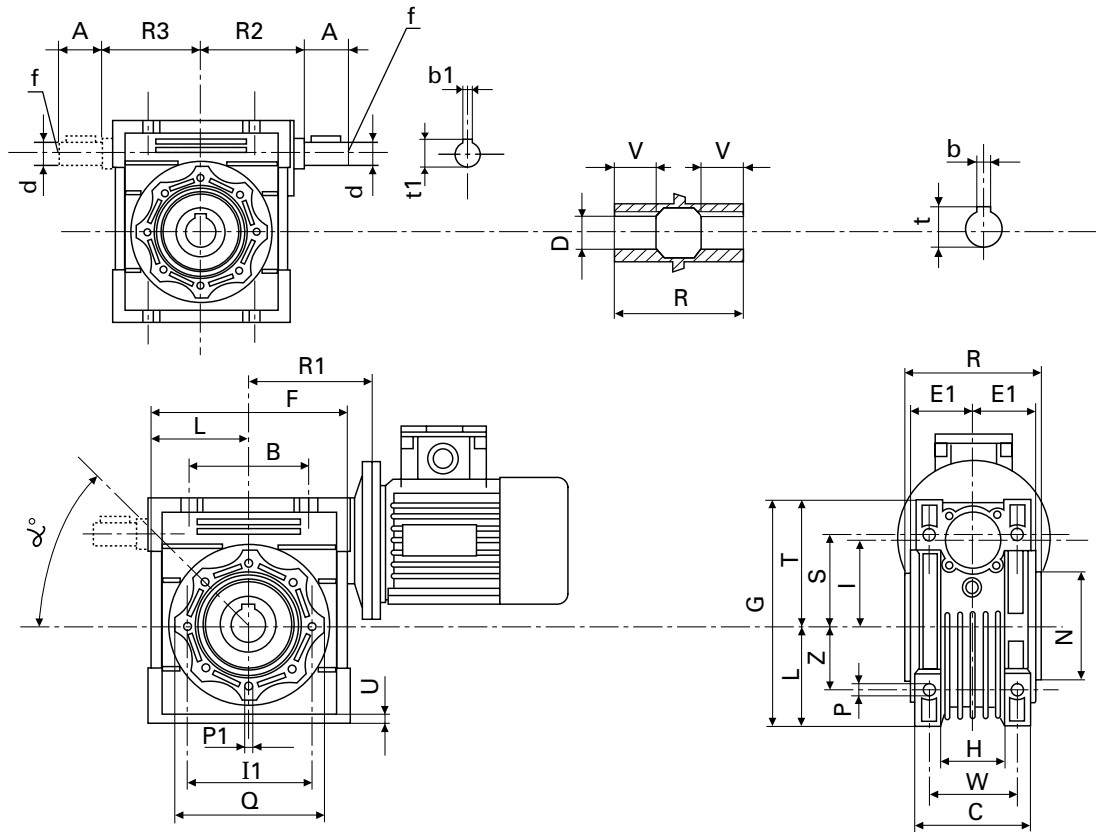

	B	A	F	D(H7)	d(j6)	G	H	R1	R	R2	R3	L	I	C	I1	N(h8)	E1	P	Q
<b>030</b>	54	20	80	14	9	97	32	55	63	51	45	40	30	56	65	55	29	6.5	75
<b>040</b>	70	23	100	18	11	121.5	43	70	78	60	53	50	40	71	75	60	36.5	6.5	87
<b>050</b>	80	30	120	25	14	144	49	80	92	74	64	60	50	85	85	70	43.5	8.5	100
<b>063</b>	100	40	144	25	19	174	67	95	112	90	75	72	63	103	95	80	53	8.5	110
<b>075</b>	120	50	172	28	24	205	72	112.5	120	105	90	86	75	112	115	95	57	11	140
<b>090</b>	140	50	208	35	24	238	74	129.5	140	125	108	103	90	130	130	110	67	13	160
<b>110</b>	170	60	252.5	42	28	295	-	160	155	142	135	127.5	110	144	165	130	74	14	200
<b>130</b>	200	80	292.5	45	30	335	-	180	170	162	155	147.5	130	155	215	180	81	16	250

	S	T	U	V	Z	W	P1	α	b	b1	f	t	t1	Weight in kg. excluding motor
<b>030</b>	44	57	5.5	21	27	44	M6x11(n.4)	0°	5	3	-	16.3	10.2	1.2
<b>040</b>	55	71.5	6.5	26	35	60	M6x8(n.4)	45°	6	4	-	20.8	12.5	2.3
<b>050</b>	64	84	7	30	40	70	M8x10(n.4)	45°	8	5	M6	28.3	16.0	3.5
<b>063</b>	80	102	8	36	50	85	M8x14(n.4)	45°	8	6	M6	28.3	21.5	6.2
<b>075</b>	93	119	10	40	60	90	M8x14(n.4)	45°	8	8	M8	31.3	27.0	8.5
<b>090</b>	102	135	11	45	70	100	M10x18(n.4)	45°	10	8	M8	38.3	27.0	12
<b>110</b>	125	167.5	14	50	85	115	M10x18(n.4)	45°	12	8	M10	45.3	31.0	35
<b>130</b>	140	187.5	15	60	100	120	M12x21(n.4)	45°	14	8	M10	48.8	33.0	53

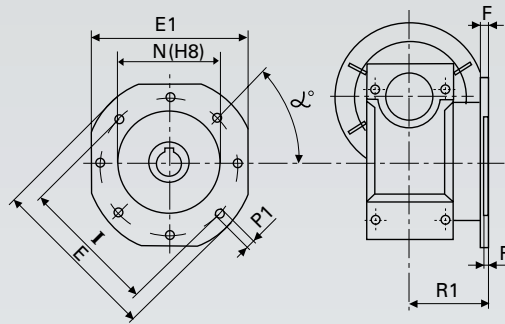

		030	040	050	063	075	090	110	130
FA	R1	54.5	67	90	82	111	111	131	140
	F	6	7	9	10	13	13	15	15
	R	4	4	5	6	6	6	6	6
	N	50	60	70	115	130	152	170	180
	I	68/72*	75/95*	85/110*	150/165*	165/185*	175/195*	230	255
	P1	6.5(n°4)	9(n°4)	11(n°4)	11(n°4)	14(n°4)	14(n°4)	14(n°8)	16(n°8)
	E	80	110	125	180	200	210	280	320
	E1	70	95	110	142	170	200	260	290
	α°	45°	45°	45°	45°	45°	45°	45°	22.5°
FB	R1	-	97	120	112	90	122	180	-
	F	-	7	9	10	13	18	15	-
	R	-	4	5	6	6	6	6	-
	N	-	60	70	115	110	180	170	-
	I	-	75/95*	85/110*	150/165*	130/145*	215/230*	230	-
	P1	-	9(n°4)	11(n°4)	11(n°4)	14(n°4)	14(n°4)	14(n°8)	-
	E	-	110	125	180	160	250	280	-
	E1	-	95	110	142	-	-	260	-
	α°	-	45°	45°	45°	45°	45°	45°	-
FC	R1	-	80	89	98	-	110	-	-
	F	-	9	10	10	-	17	-	-
	R	-	5	5	5	-	6	-	-
	N	-	95	110	130	-	130	-	-
	I	-	115	130	165	-	165/185*	-	-
	P1	-	9.5(n°4)	9.5(n°4)	11(n°4)	-	11(n°4)	-	-
	E	-	140	160	200	-	200	-	-
	α°	-	45°	45°	45°	-	45°	-	-
FD	R1	-	58	72	107	-	151	-	-
	F	-	12	14.5	10	-	13	-	-
	R	-	5	5	5	-	6	-	-
	N	-	80	95	130	-	152	-	-
	I	-	100/110*	115/125*	165	-	175/195*	-	-
	P1	-	9(n°4)	11(n°4)	11(n°4)	-	14(n°4)	-	-
	E	-	120	140	200	-	210	-	-
	α°	-	45°	45°	45°	-	45°	-	-
FE	R1	-	-	-	80.5	-	-	-	-
	F	-	-	-	16.5	-	-	-	-
	R	-	-	-	5	-	-	-	-
	N	-	-	-	110	-	-	-	-
	I	-	-	-	130/145*	-	-	-	-
	P1	-	-	-	11(n°4)	-	-	-	-
	E	-	-	-	160	-	-	-	-
α°	-	-	-	45°	-	-	-	-	

\* The values marked have a slot instead of a hole, therefore the fixing centreline, value, may be within the range indicated, an intermediate value is recommended.

## CHTPC WORM GEAR WITH PRE-STAGE MODULE



### DESIGNATION CHTPC / CHM - CHME

TYPE	SIZE	i =	P.A.M.	MOUNT. POS
CHTPC	63	3	63B5	If supplied coupled with CHM or CHME types specify the position of these, when the pre-stage module is supplied by itself it is prepared for universal assembly.
	71	3	71B5	
	80	3	80B5	
	90	2.42	90B5	

### EXAMPLE ORDER FOR A CHTPC COUPLED TO A CHM OR CHME GEAR

CHTPC	90	CHM	110	i=242 (2.42x100)	PAM 90B5	POS.B3
-------	----	-----	-----	------------------	----------	--------

If the motor is also required, please specify:

Size	es. 90 L4
Power	es. Kw 1.5
Poles	es. 4
Voltage	es. V230/400
Frequency	es. 50 Hz
Flange	sempre B 5

N.B. From size 25 to 63 the gears are always supplied in the Universal position and can therefore be mounted in any position, from size 75 to size 130 if the position required differs from B3 it must be specified.

In particular, in the event that a gear in position B3 is to be mounted in positions V5 or V6, the bearing positioned in the upper side must be lubricated using suitable grease that ensures proper lubrication.

We have tested Tecnolubeseal POLYMER 400/2 grease.

## POSSIBLE COUPLINGS FOR CHTPC / CHM - CHME

CHM - CHME	i	CHTPC 63	CHTPC 71	CHTPC 80	CHTPC 90
40	all	#			
40	da 7.5 a 40	#			
50	da 40 a 100	#			
50	da 7.5 a 50		#		
63	da 50 a 100	#			
63	da 30 a 100		#		
75	da 30 a 100		#		
75	da 30 a 100			#	
90	da 30 a 100		#		
90	da 30 a 100			#	
110	da 40 a 100			#	
110	da 30 a 100				#
130	da 30 a 100				#

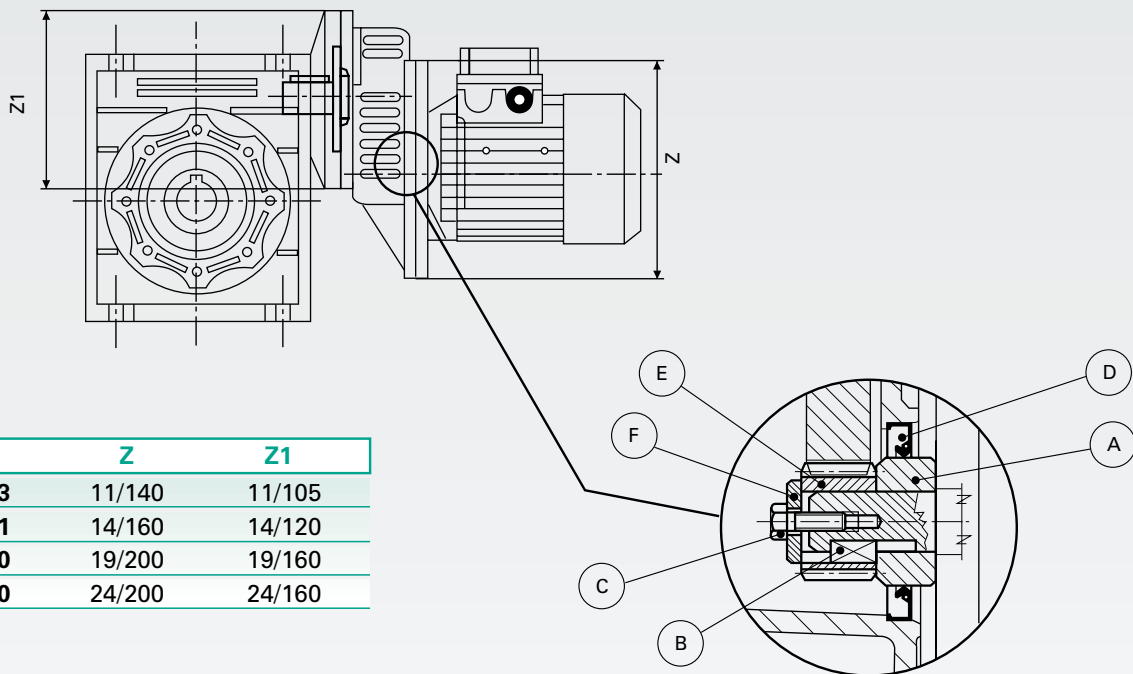

	Z	Z1
<b>CHTPC 63</b>	11/140	11/105
<b>CHTPC 71</b>	14/160	14/120
<b>CHTPC 80</b>	19/200	19/160
<b>CHTPC 90</b>	24/200	24/160

### PINION ASSEMBLY INSTRUCTIONS

- 1) Assemble the spacer A (if necessary heat between 80° and 100° C) onto the driving shaft and block it with Loctite 638 for coaxial blockings
- 2) Insert the key B included in the kit
- 3) Assemble the pinion E (if necessary heat between 80° and 100° C) onto the driving shaft
- 4) Fix the washer F using the screw C
- 5) Assemble the oil seal D in the direction shown in the drawing
- 6) Insert the motor with the pinion, taking care not to damage the oil seal

\* The size CHTPC 90 is fixed using a ring and dowel

# CHTPC/CHM PERFORMANCE WITH 4-POLE MOTORS – 1400 REVS. INPUT

TYPE	i=ratio	n2 r/min	Kw=P1	Nm=T2
	90	15.6	0.18	61
	120	11.7	0.18	52
<b>CHTPC63</b>	150	9.3	0.18	46
<b>CHM040</b>	180	7.8	0.18	46
	240	5.8	0.18	40
	300	4.7	0.18	36

TYPE	i=ratio	n2 r/min	Kw=P1	Nm=T2
	90	15.6	0.37	153
	120	11.7	0.37	190
<b>CHTPC71</b>	150	9.3	0.37	220
<b>CHM075</b>	180	7.8	0.37	236
	180	7.8	0.25	159
	240	5.8	0.25	208
	300	4.7	0.25	210

TYPE	i=ratio	n2 r/min	Kw=P1	Nm=T2
	90	15.6	0.18	69
	120	11.7	0.18	85
<b>CHTPC63</b>	150	9.3	0.18	89
<b>CHM050</b>	180	7.8	0.18	88
	240	5.8	0.18	76
	300	4.7	0.18	65

TYPE	i=ratio	n2 r/min	Kw=P1	Nm=T2
	90	15.6	0.75	307
	120	11.7	0.55	278
<b>CHTPC80</b>	150	9.3	0.55	260
<b>CHM075</b>				

TYPE	i=ratio	n2 r/min	Kw=P1	Nm=T2
	90	15.6	0.25	97
<b>CHTPC71</b>	120	11.7	0.25	110
<b>CHM050</b>	150	9.3	0.25	112

TYPE	i=ratio	n2 r/min	Kw=P1	Nm=T2
	180	7.8	0.37	260
<b>CHTPC71</b>	240	5.8	0.37	320
<b>CHM090</b>	300	4.7	0.37	345

TYPE	i=ratio	n2 r/min	Kw=P1	Nm=T2
	150	9.3	0.18	101
<b>CHTPC63</b>	180	7.8	0.18	115
<b>CHM063</b>	240	5.8	0.18	136
	300	4.7	0.18	121

TYPE	i=ratio	n2 r/min	Kw=P1	Nm=T2
	90	15.6	0.75	320
<b>CHTPC80</b>	120	11.7	0.75	397
<b>CHM090</b>	150	9.3	0.75	426
	180	7.8	0.75	425
	240	5.8	0.55	374

TYPE	i=ratio	n2 r/min	Kw=P1	Nm=T2
	90	15.6	0.37	145
	90	15.6	0.25	98
<b>CHTPC71</b>	120	11.7	0.37	184
<b>CHM063</b>	120	11.7	0.25	124
	150	9.3	0.37	192
	150	9.3	0.25	129
	180	7.8	0.25	164
	240	5.8	0.25	139
	300	4.7	0.25	128

TYPE	i=ratio	n2 r/min	Kw=P1	Nm=T2
	120	11.7	0.75	421
<b>CHTPC80</b>	150	9.3	0.75	496
<b>CHM110</b>	180	7.8	0.75	569
	240	5.8	0.75	617
	300	4.7	0.55	585

TYPE	i=ratio	n2 r/min	Kw=P1	Nm=T2
	96.8	14.5	1.50	679
<b>CHTPC90</b>	121	11.6	1.50	801
<b>CHM110</b>	145.2	9.6	1.50	810
	145.2	9.6	1.10	595
	193.6	7.2	1.10	660

TYPE	i=ratio	n2 r/min	Kw=P1	Nm=T2
	96.8	14.5	1.50	679
<b>CHTPC90</b>	121	11.6	1.50	813
<b>CHM130</b>	145.2	9.6	1.50	917
	193.6	7.2	1.50	1013
	242	5.8	1.10	848

The choice of power installed is tied to the unification of the motors, therefore it is sometimes in exuberance compared to the gear; always verify the maximum torque indicated when making the selection and if in doubt please contact our technical office.



## CHTPC - CHM DIMENSIONS

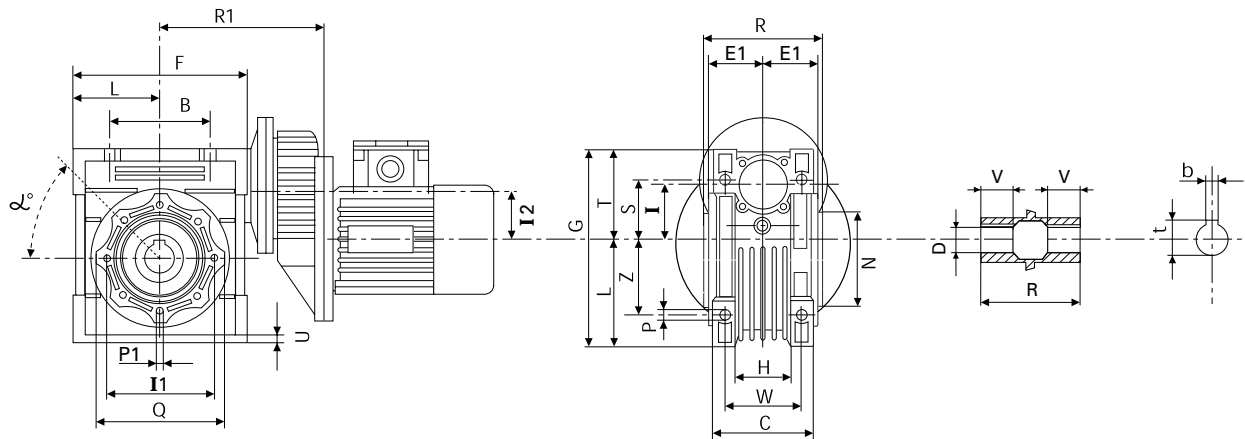

CHTPC CHM	B	F	D(H7)	G	H	R1	R	L	I	I2	C	I1	N(H8)	E1	P	Q	S	T
63+040	70	100	18	121.5	43	123	78	50	40	40	71	75	60	36.5	6.5	87	55	71.5
63+050	80	120	25	144	49	133	92	60	50	40	85	85	70	43.5	8.5	100	64	84
71+050	80	120	25	144	49	143	92	60	50	50	85	85	70	43.5	8.5	100	64	84
63+063	100	144	25	174	67	148	112	72	63	40	103	95	80	53	8.5	110	80	102
71+063	100	144	25	174	67	158	112	72	63	50	103	95	80	53	8.5	110	80	102
71+075	120	172	28	205	72	176	120	86	75	50	112	115	95	57	11	140	93	119
80+075	120	172	28	205	72	186	120	86	75	63	112	115	95	57	11	140	93	119
71+090	140	208	35	238	74	193	140	103	90	50	130	130	110	67	13	160	102	135
80+090	140	208	35	238	74	203	140	103	90	63	130	130	110	67	13	160	102	135
80(90)+110	170	252.5	42	295	-	233	155	127.5	110	63	144	165	130	74	14	200	125	167.5
80(90)+130	200	292.5	45	335	-	253	170	147.5	130	63	155	215	180	81	16	250	140	187.5

CHTPC CHM	U	V	Z	W	P1	$\alpha^\circ$	b	t	Weight in Kg. excluding motor
63+040	6.5	26	35	60	M6x8n.4	45°	6	20.8	3.9
63+050	7	30	40	70	M8x10n.4	45°	8	28.3	5.2
71+050	7	30	40	70	M8x10n.4	45°	8	28.3	5.8
63+063	8	36	50	85	M8x14n.8	45°	8	28.3	7.9
71+063	8	36	50	85	M8x14n.8	45°	8	28.3	8.5
71+075	10	40	60	90	M8x14n.8	45°	8	31.3	11
80+075	10	40	60	90	M8x14n.8	45°	8	31.3	12.6
71+090	11	45	70	100	M10x18n.8	45°	10	38.3	14.3
80+090	11	45	70	100	M10x18n.8	45°	10	38.3	16.2
80(90)+110	14	50	85	115	M10x18n.8	45°	12	45.3	39
80(90)+130	15	60	100	120	M12x21n.8	45°	14	48.8	67.2

N.B. For the side flange and double extended input worm dimensions see the corresponding size of the CHM series. See pages 8 and 9.

COMBINED WORM GEAR CHM/CHM-CHME  
CHMR/CHM-CHME



DIRECTION OF ROTATION

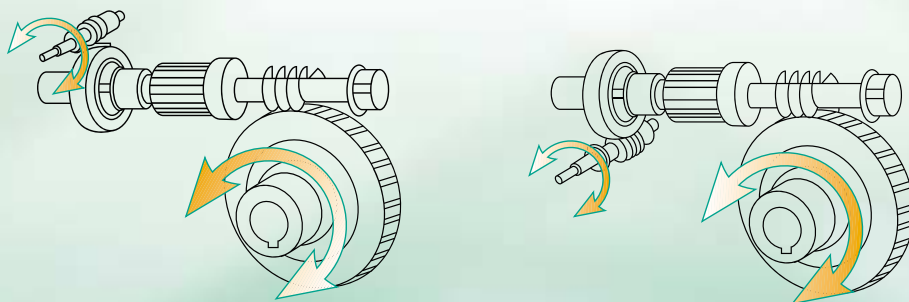

**DESIGNATION CHM/CHM - CHME E CHMR/CHM - CHME**

TYPE	SIZE(1)	VERSION(2)	FLANGE POS.(3)	i	EXEC.(4)	M.M.F.	MOUNT. POS.(3)
CHM/CHM	030/040	FA	1	300	OAD		U
CHM/CHME	030/050	FB	2	400	OAS		B3
CHMR/CHM	030/063	FC		500	OBD		B8
CHMR/CHME	040/075	FD		600	OBS		B6
	040/090	FE		750	VAD		B7
	050/110			900	VAS		V5
	063/130			1200	VBD		V6
				1500	VBS		
				1800			
				2400			

See page 4

For the motor mounting flanges (M.M.F.) see the table showing the types available.  
 For the executions see the table with drawings, if not specified OBS would be supplied.  
 The mounting position refers to the second gear.

**EXAMPLE ORDER**

<b>CHM/CHM</b>	<b>040/090</b>	<b>FA(5)</b>	<b>2(5)</b>	<b>500</b>	<b>OAD</b>	<b>63 B14</b>	<b>V5</b>
----------------	----------------	--------------	-------------	------------	------------	---------------	-----------

If the motor is also required, please specify:

- Size es. 63 B4
- Power es. Kw 0.18
- Poles es. 4
- Voltage es. V230/400
- Frequency es. 50 Hz
- Flange es. B 14

N.B. From size 25 to 63 the gears are always supplied in the Universal position and can therefore be mounted in any position, from size 75 to size 130 if the position required differs from B3 it must be specified.  
 In particular, in the event that a gear in position B3 is to be mounted in positions V5 or V6, the bearing positioned in the upper side must be lubricated using suitable grease that ensures proper lubrication.  
 We have tested Tecnolubeseal POLYMER 400/2 grease.

- 1) see page 17
- 2) see page 9
- 3) see page 5
- 4) see page 16
- 5) lack of instructions indicates that the gear is not equipped with an output flange.

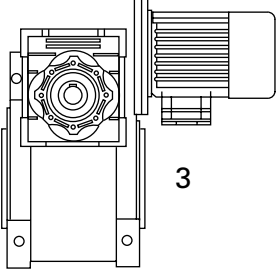
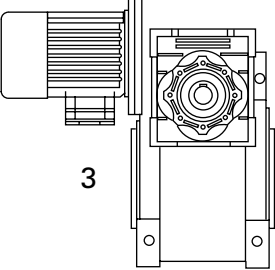
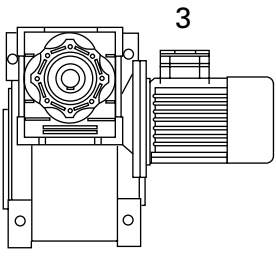
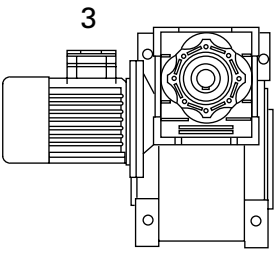
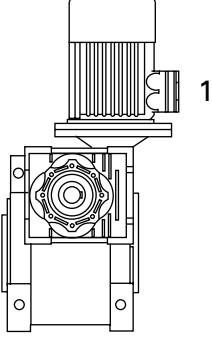
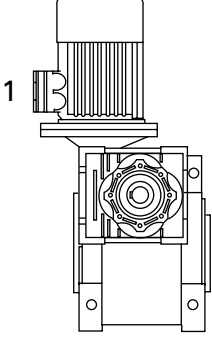
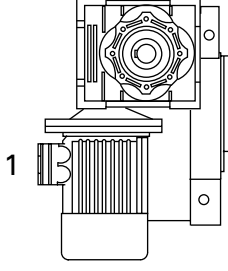
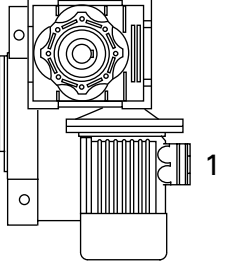

# EXECUTION

 <p>OAD</p>	 <p>OAS</p>
 <p>OBD</p>	 <p>OBS</p>
 <p>VAD</p>	 <p>VAS</p>
 <p>VBS</p>	 <p>VBD</p>

The execution determines the mounting position of the first gear in relation to the second gear. If not otherwise specified at the time of order, the group will be supplied in the OBS execution. The placing position refers to the second gear.

## CHM/CHM PERFORMANCE WITH 4-POLE MOTORS – 1400 REVS. INPUT

TYPE	i=ratio	n2 r/min	Kw=P1	Nm=T2
	300	4.7	0.09*	70
	400	3.5	0.09*	63
	500	2.8	0.09*	57
	600	2.3	0.09*	72
<b>CHM</b>	750	1.9	0.09*	72
<b>030/040</b>	900	1.6	0.09*	73
	1200	1.2	0.09*	65
	1500	0.9	0.09*	73
	1800	0.8	0.09*	73
	2400	0.6	0.09*	65

TYPE	i=ratio	n2 r/min	Kw=P1	Nm=T2
	300	4.7	0.37	405
	400	3.5	0.37	523
	500	2.8	0.37	550
	600	2.3	0.37	605
<b>CHM</b>	750	1.9	0.25	538
<b>040/090</b>	900	1.6	0.25	533
	1200	1.2	0.18	629
	1500	0.9	0.18	588
	1800	0.8	0.18*	492
	2400	0.6	0.18*	625

TYPE	i=ratio	n2 r/min	Kw=P1	Nm=T2
	300	4.7	0.18	142
	400	3.5	0.18	127
	500	2.8	0.09	123
	600	2.3	0.09	143
<b>CHM</b>	750	1.9	0.09	148
<b>030/050</b>	900	1.6	0.09*	141
	1200	1.2	0.09*	118
	1500	0.9	0.09*	139
	1800	0.8	0.09*	155
	2400	0.6	0.09*	124

TYPE	i=ratio	n2 r/min	Kw=P1	Nm=T2
	300	4.7	0.75	871
	400	3.5	0.75	1013
	500	2.8	0.55	984
	600	2.3	0.55	1062
<b>CHM</b>	750	1.9	0.55	1128
<b>050/110</b>	900	1.6	0.37	1079
	1200	1.2	0.25	943
	1500	0.9	0.25	1064
	1800	0.8	0.25	1075
	2400	0.6	0.18	1001

TYPE	i=ratio	n2 r/min	Kw=P1	Nm=T2
	300	4.7	0.22	210
	400	3.5	0.18	222
	500	2.8	0.18	205
	600	2.3	0.18*	208
<b>CHM</b>	750	1.9	0.18*	216
<b>030/063</b>	900	1.6	0.09	200
	1200	1.2	0.09	236
	1500	0.9	0.09*	204
	1800	0.8	0.09*	202
	2400	0.6	0.09*	220

TYPE	i=ratio	n2 r/min	Kw=P1	Nm=T2
	300	4.7	1.50	1789
	400	3.5	1.10	1519
	500	2.8	1.10	1629
	600	2.3	0.75	1631
<b>CHM</b>	750	1.9	0.75	1804
<b>063/130</b>	900	1.6	0.75	1826
	1200	1.2	0.55	1705
	1500	0.9	0.37	1674
	1800	0.8	0.37	1698
	2400	0.6	0.25	1624

TYPE	i=ratio	n2 r/min	Kw=P1	Nm=T2
	300	4.7	0.37	405
	400	3.5	0.25	336
	500	2.8	0.25	307
	600	2.3	0.18	362
<b>CHM</b>	750	1.9	0.18	391
<b>040/075</b>	900	1.6	0.18*	325
	1200	1.2	0.18*	359
	1500	0.9	0.09	360
	1800	0.8	0.09	404
	2400	0.6	0.09*	330

N.B. The powers marked with an asterisk are higher than those that the gear allows, therefore the applicative choice must be made in accordance with the torque and not the power.

The gear ratios are those most frequently requested. It is possible to obtain multiple combinations using the various ratios of the two single gears.

## DIMENSIONS OF COMBINED GEARS CHM – CHM / CHMR – CHM

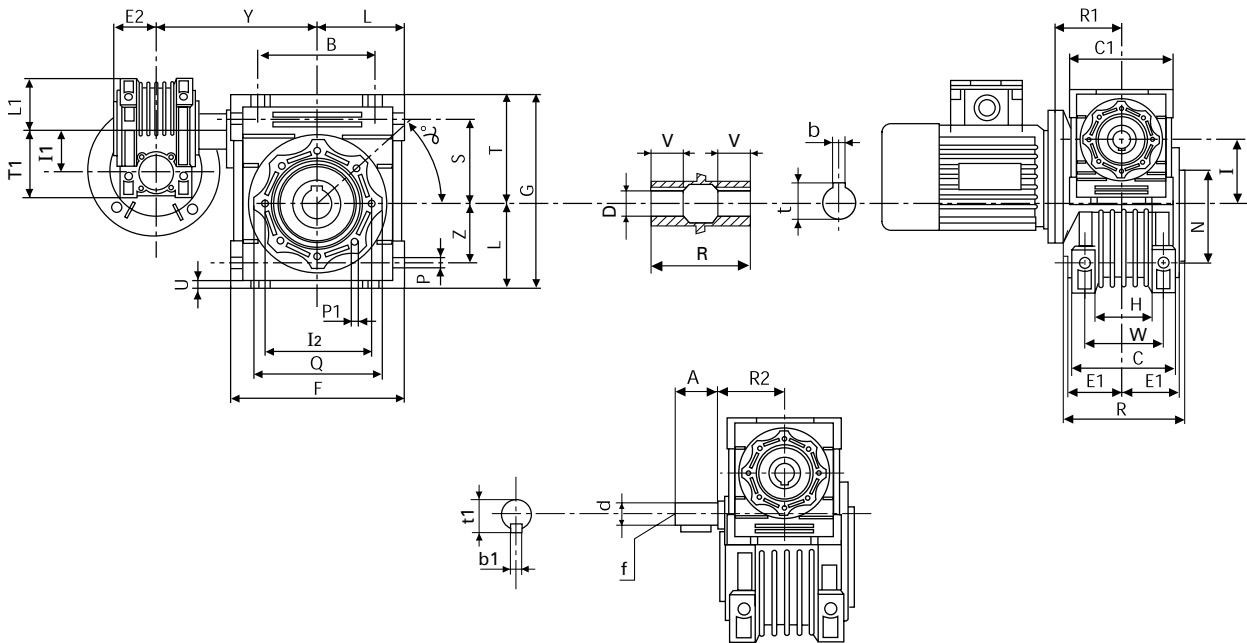

CHM-CHM	B	A	F	C1	D(H7)	d(j6)	G	H	R1	R	R2	L	L1	I	I1	C	I2	N(H8)	E1	E2	P
030/040	70	20	100	80	18	9	121.5	43	55	78	51	50	40	40	30	71	75	60	36.5	29	6.5
030/050	80	20	120	80	25	9	144	49	55	92	51	60	40	50	30	85	85	70	43.5	29	8.5
030/063	100	20	144	80	25	9	174	67	55	112	51	72	40	63	30	103	95	80	53	29	8.5
040/075	120	23	172	100	28	11	205	72	70	120	60	86	50	75	40	112	115	95	57	36.5	11
040/090	140	23	208	100	35	11	238	74	70	140	60	103	50	90	40	130	130	110	67	36.5	13
050/110	170	30	252.5	120	42	14	295	-	80	155	74	127.5	60	110	50	144	165	130	74	43.5	14
063/130	200	40	292.5	144	45	19	335	-	95	170	90	147.5	72	130	63	155	215	180	81	53	16

CHM-CHM	Q	S	T	T1	U	V	Z	Y	W	P1	a	b	b1	f	t	t1	Weight in Kg. excluding motor
030/040	87	55	71.5	57	6.5	26	35	120	60	M6x8(n.4)	45°	6	3	-	20.8	10.2	3.9
030/050	100	64	84	57	7	30	40	130	70	M8x10(n.4)	45°	8	3	-	28.3	10.2	5.0
030/063	110	80	102	57	8	36	50	145	85	M8x14(n.8)	45°	8	3	-	28.3	10.2	7.8
040/075	140	93	119	71.5	10	40	60	165	90	M8x14(n.8)	45°	8	4	-	31.3	12.5	11.5
040/090	160	102	135	71.5	11	45	70	182	100	M10x18(n.8)	45°	10	4	-	38.3	12.5	15
050/110	200	125	167.5	84	14	50	85	225	115	M10x18(n.8)	45°	12	5	M6	45.3	16.0	39.2
063/130	250	140	187.5	102	15	60	100	245	120	M12x21(n.4)	45°	14	6	M6	48.8	21.5	70

N.B. For the side flange and double extended input worm dimensions see the corresponding size of the CHM models. See pages 8 and 9.

## TORQUE ARM

TYPE	I	R	F	H	Ø E	A	B	Ø C	Ø d	Ø P	N°	Weight per kit kg.
CHT MV 25*	70	15	17.5	14	8	33.5	118.5	55	7	45	4	0.17
CHT MV 30*	85	15	24	14	8	38	138	65	7	55	8	0.18
CHT MV 40	100	18	31.5	14	10	44	162	75	7	60	8	0.24
CHT MV 50	100	18	38.5	14	10	50	168	85	9	70	8	0.27
CHT MV 63	150	18	49	14	10	55	223	95	9	80	8	0.57
CHT MV 75	200	30	47.5	25	20	70	300	115	9	95	8	1.10
CHT MV 90	200	30	57.5	25	20	80	310	130	11	110	8	1.26
CHT MV 110	250	35	62	30	25	100	385	165	11	130	8	1.92
CHT MV 130/150	250	35	69	30	25	125	410	215	14	180	8	2.23

\* Without vibration resistant bushing

The anchoring point of the torque arm is equipped with a vibration resistant bushing.

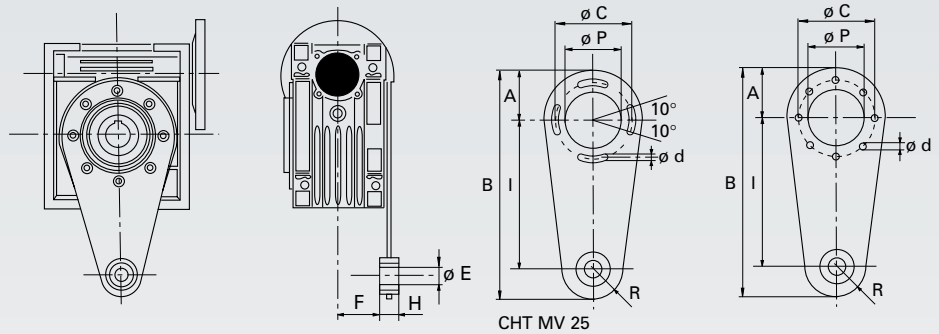

## SINGLE OUTPUT SHAFT KIT

TYPE	A	Ø d	B	b	t 1	R	L	d 2	Weight per kit kg.
CHT MVS 25	23	11	25.5	4	12.5	55.5	81	-	0.07
CHT MVS 30	30	14	32.5	5	16	69.5	102	M6x16	0.14
CHT MVS 40	40	18	43	6	20.5	85	128	M6x16	0.27
CHT MVS 50	50	25	53.5	8	28	99.5	153	M10x22	0.60
CHT MVS 63	50	25	53.5	8	28	119.5	173	M10x22	0.67
CHT MVS 75	60	28	63.5	8	31	128.5	192	M10x22	0.94
CHT MVS 90	80	35	84.5	10	38	149.5	234	M12x28	1.79
CHT MVS 110	80	42	84.5	12	45	164.5	249	M16x35	2.70
CHT MVS 130	80	45	85	14	48.5	180	265	M16x35	3.60

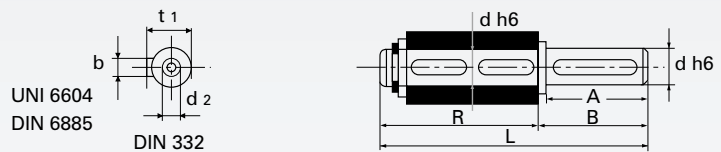

## DOUBLE OUTPUT SHAFT KIT

TYPE	A	Ø d	B	R	b	t 1	L	d 2	Weight per kit kg.
CHT MVD 25	23	11	25.5	50	4	12.5	101	-	0.11
CHT MVD 30	30	14	32.5	63	5	16	128	M6x16	0.16
CHT MVD 40	40	18	43	78	6	20.5	164	M6x16	0.34
CHT MVD 50	50	25	53.5	92	8	28	199	M10x22	0.75
CHT MVD 63	50	25	53.5	112	8	28	219	M10x22	0.84
CHT MVD 75	60	28	63.5	120	8	31	247	M10x22	1.20
CHT MVD 90	80	35	84.5	140	10	38	309	M12x28	2.50
CHT MVD 110	80	42	84.5	155	12	45	324	M16x35	3.44
CHT MVD 130	80	45	85	170	14	48.5	340	M16x35	4.25

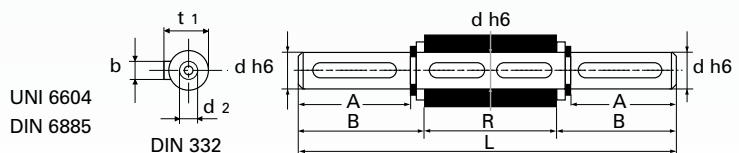



# COVER

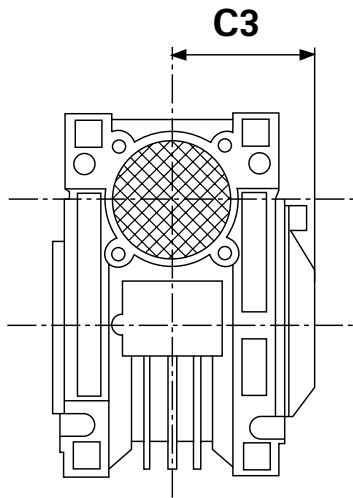

TYPE	C3
030	43
040	50
050	59
063	70
075	75
090	87
110	95
130	103

## REDUCTION BUSHINGS KIT

SINGLE				
TYPE	$\phi i/\phi e$	L	Key	Weight per kit kg
CHT BRM-S	9/11	20	4/3 x 4 x 11 RB*	0.006
CHT BRM-S	11/14	30	5/4 x 6 x 10 RB*	0.015
CHT BRM-S	14/19	40	6 x 5 x 30 *	0.045
CHT BRM-S	19/24	50	6 x 5.5 x 20 * 8 x 5.5 x 40 *	0.07
CHT BRM-S	24/28	60	8 x 9 x 40 *	0.08
CHT BRM-S	28/38	80	10 x 7 x 60 *	0.33
CHT BRM-S	38/42	110	12/10 x 10 x 48 RB*	0.22

DOUBLE				
TYPE	$\phi i/\phi e$	L	Key	Weight per kit kg
CHT BRM-D	11/19	40	6 x 6 x 30 *	0.06
CHT BRM-D	14/24	50	8 x 7 x 40 A	0.12
CHT BRM-D	19/28	60	8 x 7 x 50 A	0.16
CHT BRM-D	24/38	80	10 x 8 x 60 A	0.44

\* to drawing

Tongue acc. to UNI 6604 – DIN 6885  
Quenched

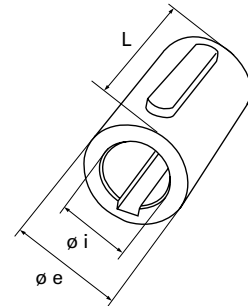
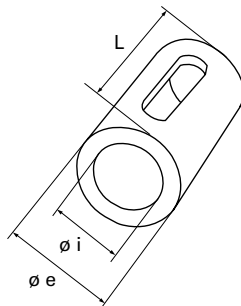

## THREE-PHASE ELECTRIC MOTORS

### TECHNICAL DATA FOR 4-POLE MOTORS

(1400 RPM)

TYPE	POWER kW	VOLTAGE V	CURRENT 400 V	TORQUE N/m	EFFICIENCY %	POWER FACTOR Ø	WEIGHT Kg.
CHT 56 B4	0.09	230/400	0.43	0.64	50	0.61	3.2
CHT 63 A4	0.12	230/400	0.47	0.86	57	0.64	3.9
CHT 63 B4	0.18	230/400	0.70	1.27	57	0.65	4.5
CHT 63 C4	0.22	230/400	0.92	1.77	59	0.67	4.8
CHT 71 A4	0.25	230/400	0.84	1.77	60	0.72	5.6
CHT 71 B4	0.37	230/400	1.12	2.58	65	0.74	6.2
CHT 71 C4	0.55	230/400	1.61	3.81	66	0.75	7.0
CHT 80 A4	0.55	230/400	1.59	3.81	67	0.75	8.9
CHT 80 B4	0.75	230/400	1.94	5.20	72	0.78	10.0
CHT 80 D4	1.10	230/400	2.67	7.60	76.2	0.78	11.0
CHT 90 S4	1.10	230/400	2.64	7.50	76.2	0.79	12.1
CHT 90 L4	1.50	230/400	3.46	10.20	78.5	0.80	14.3
CHT 90 LL4	1.85	230/400	4.30	9.24	79	0.78	16.0
CHT 100 L A4	2.20	230/400	4.86	14.80	81.0	0.81	21.0
CHT 100 L B4	3.00	230/400	6.50	20.20	82.6	0.81	24.7
CHT 112 M4	4.00	230/400	8.26	26.70	84.2	0.83	30.1
CHT 132 S4	5.50	230/400	11.00	36.22	85.7	0.84	44.0
CHT 132 M4	7.50	230/400	14.64	49.40	87.0	0.85	52.0

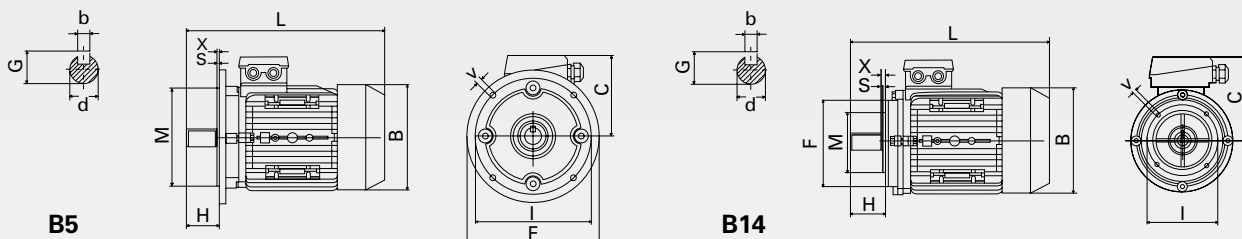

### SIZES AND DIMENSIONS

Type	Mounting dimensions (mm)										Dimensions								
	B5					B14					B	C	L						
d	H	b	G	I	M	F	X	V	S	I				M	F	X	V	S	
56	9	20	3	10.2	98	80	120	0	7	3.0	65	50	80	0	M5	2.5	120	100	195
63	11	23	4	12.5	115	95	140	0	10	3.0	75	60	90	0	M5	2.5	130	110	215
71	14	30	5	16	130	110	160	0	10	3.5	85	70	105	0	M6	2.5	145	117	255
80	19	40	6	21.5	165	130	200	0	12	3.5	100	80	120	0	M6	3.0	165	137	290
90S	24	50	8	27	165	130	200	0	12	3.5	115	95	140	0	M8	3.0	185	145	310
90L/90LL	24	50	8	27	165	130	200	0	12	3.5	115	95	140	0	M8	3.0	185	145	335/365
100L	28	60	8	31	215	180	250	0	15	4.0	130	110	160	0	M8	3.5	205	152	386
112M	28	60	8	31	215	150	250	0	15	4.0	130	110	160	0	M8	3.5	230	180	395
132S	38	80	10	41	265	230	300	0	15	4.0	165	130	200	0	M10	4.0	270	195	436
132M	38	80	10	41	265	230	300	0	15	4.0	165	130	200	0	M10	4.0	270	195	475

- Motors with cage rotor, closed with external surface ventilation.
- Design, construction and testing in conformity with the standards CEI2-3, international standards IEC 34-1 and the main foreign standards.
- Power-sizes in accordance with the standards IEC 72, national standards UNEL-MEC.
- Insulation class F
- Protection IP55
- S1 Continuous service

- Efficiency class EFF2
- European Directive ROHS 2002/95/CE
- NSK or SKF Bearings
- Phase separators
- 2-pole and 6-pole motors available
- Kit of feet available
- Forced ventilation kit available for single-phase and three-phase models

## FORCED VENTILATION KIT\* SINGLE-PHASE MODELS

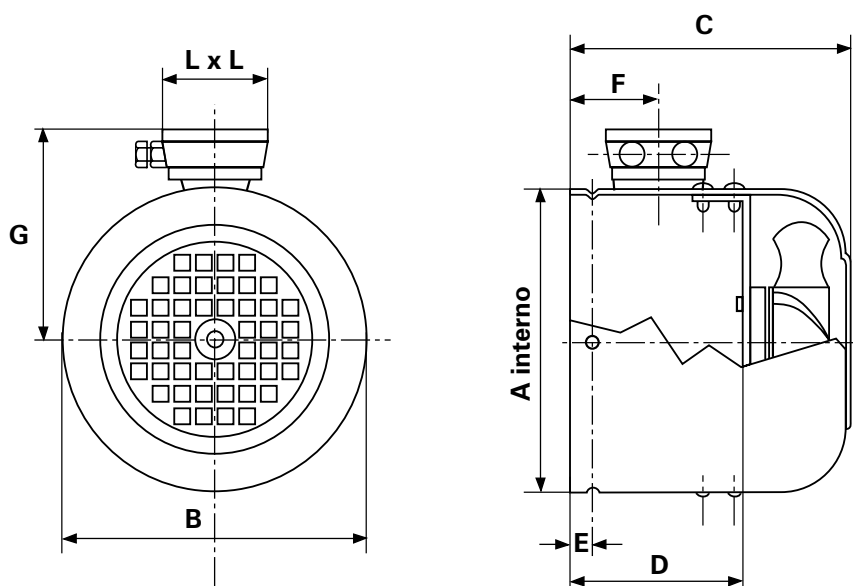

OVERALL DIMENSIONS WITH IP55 TERMINAL BOX

SIZE	VOLTAGE	HZ	SPEED NOM. MIN/1	ASSORB. WATT	CURRENT M.A.	AIR FLOW M <sup>3</sup> /H
GR.63	230	50 / 60	2750	15 / 14	120 / 100	180
GR.71	230	50 / 60	2750	15 / 14	120 / 100	180
GR.80	230	50 / 60	2750	15 / 14	120 / 100	180
GR.90	230	50 / 60	2900	42 / 36	190 / 180	340
GR.100	230	50 / 60	2900	42 / 36	190 / 180	340
GR.112	230	50 / 60	2900	42 / 36	190 / 180	340
GR.132	230	50 / 60	2900	42 / 36	190 / 180	340

SIZE	COD. IP55	A	B	C	D	E	F	G	L x L
GR.63	AS063230	121	123	102	58	6	50	104	75
GR.71	AS071230	136	138	120	70	6	50	111	75
GR.80	AS080230	153	155	130	80	6	55	125	100
GR.90	AS090230	172	176	145	75	6	60	135	100
GR.100	AS100230	195	197	150	85	8	60	150	100
GR.112	AS112230	218	220	160	100	10	60	160	100
GR.132	AS132230	255	257	180	120	10	65	175	100

\* FORCED VENTILATION KIT THREE-PHASE MODELS AVAILABLE ON REQUEST

## EXPLODED DRAWING AND SPARE PARTS LIST

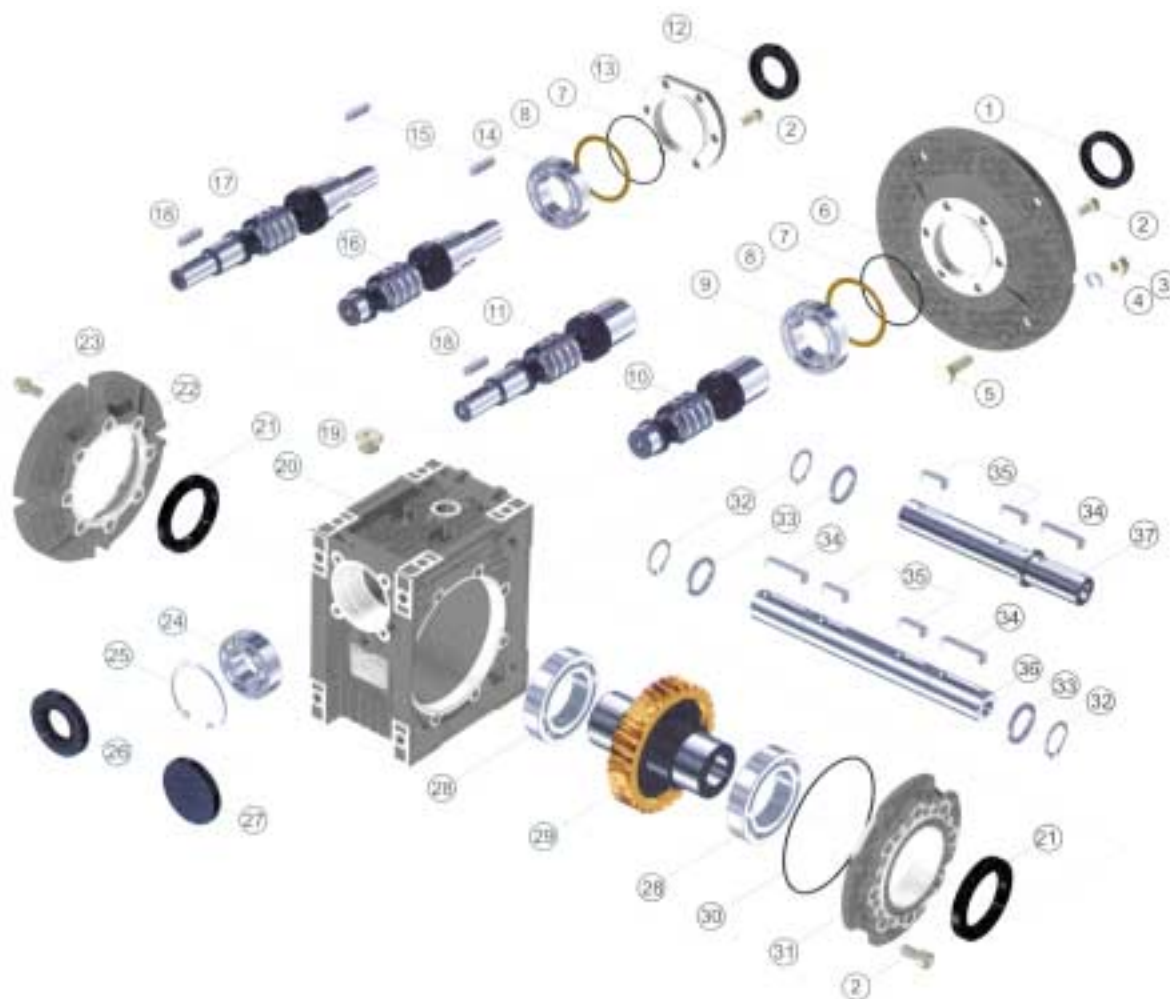

- |                                       |                                    |
|---------------------------------------|------------------------------------|
| 1 • Oil seal                          | 20 • Casing                        |
| 2 • Torx screw                        | 21 • Oil seal                      |
| 3 • Nut                               | 22 • Output flange                 |
| 4 • Washer                            | 23 • Embedded hexagonal-head screw |
| 5 • Hexagonal-head screw              | 24 • Bearing                       |
| 6 • Motor connection flange           | 25 • Seeger                        |
| 7 • O-Ring                            | 26 • Oil seal                      |
| 8 • Adjust spacer                     | 27 • Cap                           |
| 9 • Bearing                           | 28 • Bearing                       |
| 10 • Hole input worm                  | 29 • Worm wheel                    |
| 11 • Hole input and shaft output worm | 30 • O-ring                        |
| 12 • Oil seal                         | 31 • Output cover                  |
| 13 • Input cover                      | 32 • Seeger                        |
| 14 • Bearing                          | 33 • Spacer                        |
| 15 • Key                              | 34 • Key                           |
| 16 • Shaft input worm                 | 35 • Key                           |
| 17 • Double extended input shaft worm | 36 • Double output shaft           |
| 18 • Key                              | 37 • Single output shaft           |
| 19 • Oil plug                         |                                    |

# Use and maintenance instructions

## INSTALLATION

- The data shown on the identification name plate must correspond to the gear ordered
- The oil level, for the sizes 110 and 130 equipped with filling, draining and level plug, must correspond to the quantity foreseen for the assembly position requested (see catalogue), in addition, always for the sizes indicated, it will be the client's responsibility to substitute the blind plug, supplied for transport, with the corresponding plug equipped with a bleed hole included in the supply with the gear
- All of the other gears are supplied complete with permanent synthetic oil in a quantity that is sufficient for any assembly position
- The gear must be fixed on a flat surface that is sufficiently rigid in order to avoid any vibration
- The gear and the axis of the machine to be driven must be perfectly aligned
  - o In the event that knocks, overloading or blockage of the machine are foreseen, the client must install a limiting device, joints, overload cut-out etc.
- Coupling with pinions, joints, pulleys and other parts must be done after the parts have been cleaned and knocks should be avoided while assembling as they could damage the bearings and other internal parts
- In the event that the motor is supplied by the client, he must check that the flange and shaft tolerances correspond to a "normal" class; our motors satisfy this requirement
- Check that the fixing screws for the gear and the related accessories are correctly tightened
- Take suitable measures to protect the groups from any aggressive atmospheric agents
- Where foreseen, protect rotating parts from any possible contact with the operators
- If the gears are painted, protect the oil seals and the machined surfaces
- All of the gears are painted RAL 9022 grey

## OPERATION AND RUNNING-IN

- To obtain the best performance the gears must first be run-in by gradually increasing the power in the first few hours of operation, in this phase an increase in temperature is considered normal
- In the event of defective operation, noise, oil leakage, etc. stop the gear immediately and, when possible, remove the cause. Alternatively, send the piece to our factory to be controlled.

## MAINTENANCE

- The worm gears from size 25 to size 90 and the pre-stage modules are lubricated with permanent synthetic oil and therefore do not require any maintenance
- The gears size 110 and 130 are lubricated with mineral oil and are equipped with a breather plug, therefore the oil level must be checked periodically and if necessary topped up with the same oil or one that is compatible with those indicated in our catalogue
- For the gears size 110 and 130 proceed with the substitution of the oil after the first 300 working hours, replacing it with the correct quantity in accordance with the assembly position, as detailed in our catalogue, after the inside of the gear has been thoroughly washed

## WAREHOUSE STORAGE

- If the warehouse storage will be for a long time, more than 3 months, the shafts and machined surfaces should be protected using antioxidants and the oil seals should be greased

## HANDLING

- Care must be taken not to damage the oil seals and the machined surfaces when handling the groups

## DISPOSAL OF PACKAGING

- The packaging in which our gears are delivered should be sent to specialised companies for recycling if possible.

# GENERAL SALES CONDITIONS

1) ORDERS – Orders for special and standard material must always refer to offers made by CHIARAVALLI Trasmissioni SpA.

The orders are binding for the client. Once work has commenced no cancellations or order reductions will be accepted unless the client reimburses the costs of the material and the work carried out up to the moment in which the order was suspended. The quantity despatched can vary by  $\pm 5\%$  compared to the quantity ordered.

2) PRICES – The prices are those in force at the date of order. All prices are for goods delivered ex-works Premezzo, packing excluded. If there should be any increase in production and material costs over the duration of the supply, CHIARAVALLI Trasmissioni SpA reserves the right to adapt the prices accordingly, even for orders in course.

3) TERMS OF DELIVERY – Only the terms of delivery indicated by CHIARAVALLI Trasmissioni SpA are to be considered valid. However, they must only be considered as indicative. In the event of difficulty in the procurement of materials, strikes or in any event in all cases of force majeure, the terms of delivery will be automatically extended without CHIARAVALLI Trasmissioni SpA having to pay any reimbursement for damages. The client is obligated to collect special material ordered when ready.

4) DELIVERIES – Deliveries are the responsibility of the purchaser and are carried out at his own risk and peril. Any claims for shortages must be presented within 8 days of receipt of the goods. If it is agreed that the cost of transport is to be paid, even if only in part, by CHIARAVALLI Trasmissioni SpA, the latter reserves the right to choose the most economical means of transport.

5) PACKING – Packing will be invoiced at cost.

6) RETURNS – No returns for any reason will be accepted unless previously authorised and with packing, any customs clearance and the return paid for by the purchaser. To cover warehouse and administrative expenses a debit note will be issued for approx. 15% of the value of the goods returned.

7) WARRANTY – CHIARAVALLI Trasmissioni SpA promises to repair or substitute free of charge any parts that they recognise as being defective. The questioned goods must be returned to the factory of CHIARAVALLI Trasmissioni SpA, free of all expenses. The warranty will be considered cancelled in the event that the parts returned as defective have been repaired or tampered with. The repair of defective parts carried out by the purchaser will only be accepted after authorisation from CHIARAVALLI Trasmissioni SpA and after their approval of the cost estimate. CHIARAVALLI Trasmissioni SpA does not accept responsibility or pay any reimbursement for damages that occur during the use of their products, even if defective.

8) RESPONSIBILITY – CHIARAVALLI Trasmissioni SpA does not accept responsibility or pay any reimbursement for damages that occur during the use of their products, even if defective. CHIARAVALLI Trasmissioni SpA declines all responsibility in the execution of parts to a client's design under any patents.

9) PAYMENTS – Only payments carried out in the manner and terms agreed will be considered valid. Once the due date of payment has passed, CHIARAVALLI Trasmissioni SpA will calculate the interest on delayed payment at a rate that is 3% higher than the legal one, retaining the right to demand payment. In the event of delayed or missing payment by the purchaser, the company CHIARAVALLI Trasmissioni SpA reserves the right to suspend deliveries of the orders in course or to demand advance payment without having to pay any reimbursement or compensation to the purchaser. Any dispute regarding materials in manufacture or already possessed by the purchaser does not free the latter from the commitment of making the payment by the agreed date and for the whole amount of the invoice without making any deductions.

10) OWNERSHIP – All of the goods despatched remain the property of CHIARAVALLI Trasmissioni SpA until the invoice is fully paid.

11) COMPETENT COURT – Any controversy concerning business relations with CHIARAVALLI Trasmissioni SpA will be dealt with under the jurisdiction of the Court of Busto Arsizio.









#### FILIALI ITALIANE - DEPOSITI

via per Cedrate s/n  
21044 Cavaria con Premezzo - VARESE  
Tel. 0331 214511 - Fax 0331 215916

via 1° Maggio, 10  
40011 BOLOGNA / Anzola dell'Emilia  
Tel. 051 735290 - Fax 051 735366

via E. Cantoni, 3 - 20156 MILANO  
Tel. 02 33400947 - Fax 02 33400949

via Portogallo, 11 int. 51 - 35127 PADOVA  
Tel. 049 8705205 - Fax 049 8705237

via G. B. Lulli, 61 H - 10148 TORINO  
Tel. 011 2267146 - Fax 011 2266925

#### FILIALI ESTERE

**CHIARAVALLI FRANCE SARL**  
2, bis rue de Paris - F-77230 Villeneuve S/Dammartin FRANCE  
Ph. 0033 1 60946666 - Fax 0033 1 60946660  
www.chiaravalli.fr - e-mail: info@chiaravalli.fr

**CHIARAVALLI ESPAÑA SL**  
C/. Industria S/N - E - 08592 Sant Marti de Centelles Barcelona ESPAÑA  
Ph. 0034 93 8440099 - Fax 0034 93 8442193  
e-mail: chiaravall@grupobbva.net

**CHIARAVALLI CZ s.r.o.**  
Brněnská, 43 - 59101 Žďár nad Sázavou CZECH REPUBLIC  
Ph. 00420 566 686161 - Fax 00420 566 686171  
www.chiaravalli.cz - e-mail: info@chiaravalli.cz

**CHIARAVALLI POLSKA Sp. z o.o.**  
Ul. Polna, 133 - 87-100 Torun  
Ph. 0048 56 6233000 - Fax 0048 56 6238246  
www.chiaravalli.pl - e-mail: info@chiaravalli.pl



Via T. Minniti, 560  
21044 Cavaria con Premezzo (VA) - Italy  
Tel. +39.0331.214.511  
Fax +39.0331.219.430 735.067 - 735.090  
www.chiaravalli.com  
e-mail: chiaravalli@chiaravalli.it

