

Planetary Gearboxes



**BROWN
ADVANCE**

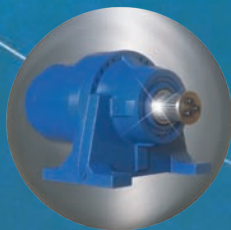

Table of contents

Description	Page
Symbols, units of measure and description	4 - 4
Technical characteristics and general information	5 - 13
EP300 Series planetary drives	14 - 25
1.0 Introduction	15 - 15
2.0 Construction versions	15 - 16
3.0 Mounting position	17 - 18
4.0 Lubrication	19 - 19
5.0 Plug positions	20 - 21
6.0 Reference oil quantity	22 - 22
8.0 Product identification scheme	23 - 25
EP300 series gear motor	26 - 77
P1=0.12KW, 0.18KW, 0.25KW n1=1400 min ⁻¹	26 - 28
P1=0.37KW n1=1400 min ⁻¹	29 - 30
P1=0.55KW n1=1400 min ⁻¹	30 - 32
P1=0.75KW n1=1400 min ⁻¹	32 - 34
P1=1.1KW n1=1400 min ⁻¹	34 - 36
P1=1.5KW n1=1400 min ⁻¹	36 - 39
P1=2.2KW n1=1400 min ⁻¹	39 - 42
P1=3.0KW n1=1400 min ⁻¹	42 - 45
P1=4.0KW n1=1400 min ⁻¹	45 - 49
P1=5.5KW n1=1400 min ⁻¹	49 - 53
P1=7.5KW n1=1400 min ⁻¹	53 - 57
P1=11KW n1=1400 min ⁻¹	57 - 62
P1=15KW n1=1400 min ⁻¹	62 - 66
P1=18.5KW n1=1400 min ⁻¹	66 - 69
P1=22KW n1=1400 min ⁻¹	69 - 72
P1=30KW n1=1400 min ⁻¹	72 - 74
P1=37KW n1=1400 min ⁻¹	74 - 75
P1=45KW, 55KW, 75KW, 90KW n1=1400 min ⁻¹	76 - 77
EP300 series gearbox (parameter and dimension)	78 - 197
EP300 gearbox (parameter and dimension), Mn'=1000 N.m	78 - 87
EP301 gearbox (parameter and dimension), Mn'=2000 N.m	88 - 97
EP303 gearbox (parameter and dimension), Mn'=3000 N.m	98 - 107
EP305 gearbox (parameter and dimension), Mn'=5000 N.m	108 - 117
EP306 gearbox (parameter and dimension), Mn'=8500 N.m	118 - 127
EP307 gearbox (parameter and dimension), Mn'=12500 N.m	128 - 137
EP309 gearbox (parameter and dimension), Mn'=18500 N.m	138 - 147
EP310 gearbox (parameter and dimension), Mn'=25000 N.m	148 - 157
EP311 gearbox (parameter and dimension), Mn'=35000 N.m	158 - 167
EP313 gearbox (parameter and dimension), Mn'=50000 N.m	168 - 177
EP315 gearbox (parameter and dimension), Mn'=80000 N.m	178 - 187
EP316 gearbox (parameter and dimension), Mn'=105000 N.m	188 - 197

Symbols, units of measure and description

Symbol	Unit	Description
AC1	(N)	Calculated thrust load at gearbox input shaft
AC2	(N)	Calculated thrust load at gearbox output shaft
A _{n1}	(N)	Rated thrust load at gearbox input shaft
A _{n2}	(N)	Rated thrust load at gearbox output shaft
F _h		Lifetime factor for gearbox calculation
F _{h1} , F _{h2}		Lifetime factor for bearing shafts calculation
f _{h1} , f _{h2}		Load corrective factor on shafts
f _m		Increase factor
f _s		Service factor
f _t		Thermal factor
f _{tp}		Temperature factor
f _v		Speed factor
h	(h)	Lifetime in hours
i		Gearbox ratio
M2'	(N.m)	Reference torque
M2	(N.m)	Torque delivered to output shaft
M _b	(N.m)	Rated brake torque
Mc2	(N.m)	Calculated torque at gearbox output
Mn2	(N.m)	Gearbox rated output torque
Mn2'	(N.m)	Gearbox rated output torque, life time=10000 hours
M _{2max}	(N.m)	Gearbox max. output torque
M _{r1}	(N.m)	Require torque at gearbox input
M _{r2}	(N.m)	Require torque at gearbox output
n1,n2	(min ⁻¹)	Angular speed at gearbox input, Angular speed at gearbox output
P	(bar)	Hydraulic oil pressure
P1	(KW)	Max. transmissible power at gearbox input
P1'	(KW)	Transmissible power at gearbox input
P2	(KW)	Transmissible power at gearbox output
Pn	(KW)	Motor rated power
Pr1	(KW)	Required input power
Pr2	(KW)	Output power at n2 max.
Pr2'	(KW)	Output power at n2 min.
Ps	(KW)	Excess power
Pt	(KW)	Gearbox thermal capacity
Q	(L/min)	Hydraulic flow rate
Rc1, Rc2	(N)	Calculated radial load of gearbox input shaft, Calculated radial load of gearbox output shaft
Rx1	(N)	Rated radial load at gearbox input re-calculated with respect to different load application points
Rx2	(N)	Rated radial load at gearbox output re-calculated with respect to different load application points
S		Safety factor
ta	(°C)	Ambient temperature
V	Cm ³	Hydraulic motor displacement
Vc	Cm ³	Theoretical hydraulic motor displacement
X	mm	Load application distance from shaft shoulder
η _d		Dynamic efficiency

TECHNICAL CHARACTERISTICS AND GENERAL INFORMATION

1. OUTPUT TORQUE

1.1 Reference torque M_2' (N.m)

Indicative output torque to easily establish the performance class for each gearbox basic size.

1.2 Gear motor delivered torque M_2 (N.m)

This is the net torque delivered to the output shaft, with installed power P_n , safety factor S , which will yield a theoretical lifetime of 10000 hours. This torque value takes gearbox efficiency into consideration.

1.3 Nominal torque M_{n2} (N.m)

Torque transmission at output at uniform continuous load, service factor $f_s=1$ for different fixed values of the life factor ($n_2 \times h$).

1.4 Rated output torque M_{n2}' (N.m)

This is the torque output the gearbox can deliver safely, based on: uniform loading and safety factor $S=1$, 10000 hours theoretical lifetime.

1.5 Max. torque M_{2max} (N.m)

It is the output torque that the reduction unit can withstand in static or highly intermittent conditions. (It is considered as instantaneous load peak torque or starting torque under load).

1.6 Required torque M_{r2} (N.m)

This is the torque corresponding to application requirements. It must always be equal or less than rated output torque M_{n2} of the selected gearbox.

1.7 Calculated torque M_{c2} (N.m)

Torque value to be used for selecting the gearbox, considering required torque M_{r2} and service factor f_s (table 3), and is obtained by formula:

$$M_{c2} = M_{r2} \times f_s < M_{n2} \quad (F1)$$

Where M_{n2} is the value for the specific application taking into consideration the life factor ($n_2 \times h$)

2. POWER

2.1 Input rated power P_1 (KW)

Power P_1 indicated in the specification table for each gearbox size is either the intermittent or continuous power which can be transmitted at the gearbox input under the following conditions:

Input speed	n_1
Theoretical duration	1000
Service factor	$f_s=1$

Check that the formula here below is always satisfied:

$$P_1' \times f_s < P_1 \quad (F2)$$

2.2 Output power P_2 (KW)

This value is the power transmitted at gearbox output. It can be calculated with the following formulas:

$$P_2 = P_1 \times \eta_d \quad (F3)$$

$$P_2 = (M_{r2} \times n_2) / 9549 \quad (F4)$$

3. THERMAL POWER P_t (KW)

This value indicates the gearbox's thermal capacity (refer to the technical data concerning the gearboxes under consideration) and is the power that can be transmitted under continuous duty, at an input speed n_1 of 1500 min^{-1} at an ambient temperature of 20°C without using a supplementary cooling device.

For a duty cycle with short operating periods and sufficiently long pauses to allow the unit to cool, thermal power is not particularly important and therefore it does not need to be taken into consideration.

At an ambient temperature other than 20°C under intermittent duty conditions and with an input speed n_1 other than 1500 min^{-1} it is possible to calculate the P_t value according to the thermal factor f_t and the speed factor f_v , shown in table (1).

Make sure that the following condition is always satisfied: $P_{r1} \leq P_t \times f_t \times f_v \quad (F5)$

Table: 1

ta max. (°C)	ft					n1	fv
	Continuous duty	Intermittent duty					
		Cyclic duration factor % (l)					
		% (l) = $t_f / (t_f + t_r) \times 100\%$ (t_f : operating time under load) (t_r : rest time)					
100%	80%	60%	40%	20%			
10	1.2	1.3	1.6	1.8	2.0	500	1.7
20	1	1.1	1.3	1.5	1.7	750	1.5
30	0.9	1	1.2	1.3	1.5	950	1.2
40	0.7	0.8	0.9	1	1.2	1500	1
50	0.5	0.6	0.7	0.8	0.9	1750	0.85
						2000	0.7
						2500	0.5
						3000	0.4

4. DYNAMIC EFFICIENCY η_d

Obtained from the ratio of output power P_2 to input power P_1 according to the following equation:

$$\eta_d = P_2 / P_1 \quad (F6)$$

Its value is a function of the transmitted power, the speed, the reduction ratio and oil temperature and viscosity. The maximum efficiency values are shown in the table (2) below.

Table 2:

N° stage			
L1	L2, R2	L3, R3	L4, R4
0.97	0.94	0.91	0.88

5. REDUCTION RATIO i

This is the ratio of gearbox input speed to gearbox output speed.

$$i = n_1 / n_2 \quad (F7)$$

6. ANGULAR SPEED

6.1 Input speed n_1 (min^{-1})

Refers to the speed of motor if motor is directly connected to gearbox. In the case of an indirect drive, this value is the speed of the motor divided by the transmission ratio of the indirect drive accessory (belt, chain, etc.).

Input speed should exceed the values indicated in the tables on gearbox technical features.

As for continuous operation in industrial applications, we recommend that speed of 1750 min^{-1} be never exceeded.

6.2 Output speed n_2 (min^{-1})

Calculated from input speed n_1 and transmission ratio i according to the following equation:

$$n_2 = n_1 / i \quad (F8)$$

7. SERVICE FACTOR f_s

Factor depending on the application type. This factor takes into consideration (with sufficient approximation) load variations which the gearbox may undergo for a specific type of duty. It also takes into consideration the selected type of the drive unit, electric or hydraulic motor and so on.

Table (3) gives indications for the service factor to be selected according to the application and operation type.

Table 3:

SERVICE FACTOR f_s						
Type of	Type of drive unit	Number of starts (/hour)				
		16	32	63	125	250
Uniform load	Electric motor	1.00	1.10	1.15	1.25	1.4
	Hydraulic motor	1.00	1.00	1.10	1.15	1.20
	Endothermic engine	1.25	--	--	--	--
Moderate shock load	Electric motor	1.10	1.15	1.20	1.40	1.60
	Hydraulic motor	1.00	1.00	1.10	1.20	1.30
	Endothermic engine	1.50	--	--	--	--
Heavy shock load	Electric motor	1.20	1.30	1.40	1.60	1.80
	Hydraulic motor	1.10	1.20	1.25	1.35	1.50
	Endothermic engine	2.00	--	--	--	--

8. SAFETY FACTOR S

This is the relationship of the gear unit rated power to the power of the electric motor actually driving the unit

$$S = P_{n1} / P_1 \quad (F9)$$

9. LIFE FACTOR f_{h1}, f_{h2}

Factor resulting by multiplying angular speed at input (n_1) or output (n_2) by actual operating working hours h , break time excluded.

$$F_{h1} = (n_1 \times h) \quad (F10)$$

$$F_{h2} = (n_2 \times h) \quad (F11)$$

Life factor is directly proportional to gearbox rpms during the whole duty time.

10. SELECTION

Some essential data are necessary for a proper gearbox of gear motor selection as indicated in table (4).

Fill in the table and send a copy to our technical service department which will select the most suitable gearbox for your application requirements.

11. GEARBOX SELECTION

a) Determine the following according to the required application:

- Service factor f_s (Table 3)
- Required gearbox working life (h)
- Required drive unit (hydraulic, electric or others)

b) Define the calculated torque with the required output torque M_{c2}

$$M_{c2} = M_{r2} \times f_s \quad (F12)$$

c) Calculate the life factor with required working life h and output speed n_2 :

$$F_{h2} = (n_2 \times h) \quad (F13)$$

d) Calculate the required reduction ratio:

$$i = n_1 / n_2 \quad (F14)$$

e) Select gearbox size which, having a reduction ratio close to the calculated value, and see the following:

$$M_{c2} \leq M_{n2} \quad (F15)$$

$$F_{h2} \leq (n_2 \times h) \quad (F16)$$

Where M_{n2} and F_{h2} are indicated in the tables on technical features for each gearbox size.

In case of applications in which the required M_{r2} and speed n_2 vary within a wide range, best

selection could be an equivalent required torque given by:

$$M_{r2} = \{[(n_2 \times h)_A \times M_A^4 + (n_2 \times h)_B \times M_B^4 + (n_2 \times h)_C \times M_C^4 + \dots] / [(n_2 \times h)_A + (n_2 \times h)_B + (n_2 \times h)_C + \dots]\}^{0.25}$$

Referred to:

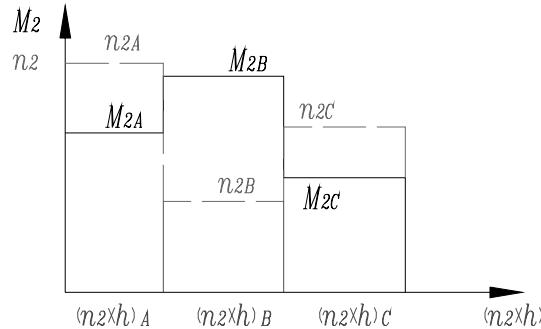

And calculating the life factor F_h with:

$$F_{h \text{ calc}} = (n_2 \times h)_A + (n_2 \times h)_B + (n_2 \times h)_C \dots \dots \quad (F17)$$

Then follow the same procedure as specified in d) and e).

Table (4): **DATE SHEET FOR SELECTING REDUCTION GEAR**

		Date application sheet for selecting reduction gear	
Name of client:		Address:	
		Date:	
Application description:			
Type of motor and drive unit: Electric / Hydraulic / Others			
Gearbox		Electric motor	
P_{r2}	Required output power:	IEC or NEMA size:	
M_{r2}	Required output torque:	Rated power: (KW)	
n_2	Output speed:	Motor voltage: (V)	
n_1	Input speed: (min^{-1})	Number of poles:	
R_{c2}	Radial load on output shaft: (N)	Frequency: (Hz)	
X_2	Load application distance: (mm)	Duty type to IEC norms: s / %	
R_{c1}	Radial load on input shaft: (N)	Starting frequency: 1/h	
X_1	Load application distance: (mm)	Motor protection degree: IP	
A_{c2}	Thrust load on output shaft: (N)	Insulation class:	
A_{c1}	Thrust load on input shaft: (N)	Brake in self-braking motor:	
h	Required life lifetime: (h)	Brake voltage: (V) Brake torque Mb: (N.m)	
t_a	Ambient temperature: ($^{\circ}\text{C}$)	HYDRAULIC MOTOR	
Type: Liner / ight angle		Brand:	
Output version:		Type:	
Accessories:		Min./Max. displacement: (cm^3)	
Mounting position:		Max. operating pressure: (bar)	
Lubricants: mineral /synthetic		Max. operating flow rate: (l/min^{-1})	
		Hydraulic brake: yes /no	
		Brake torque Mb: (N.m)	

NOTE:

The selection criteria and specifications reported in this catalogue are not valid for any applications, including those where the gearbox is to serve as a safety device preventing injury to persons or damage to objects, as is the case with hoisting equipment.

For these applications, however, the accordance with any safety rules in force. For this reason, we recommend that you seek advice from Brown Group Spain, S.A.

12. VERIFICATION

After selecting the drives units, please check the following:

a) Thermal power

Make sure that thermal power of the gearbox (shown in the tables in the chapters dealing with the gear unit series captioned) is equal to or greater than the power required by the application according to equation (F5) on page 5. If this condition is not respected, select larger gearbox or apply a forced cooling system.

Example of oil re-circulation cooling system:

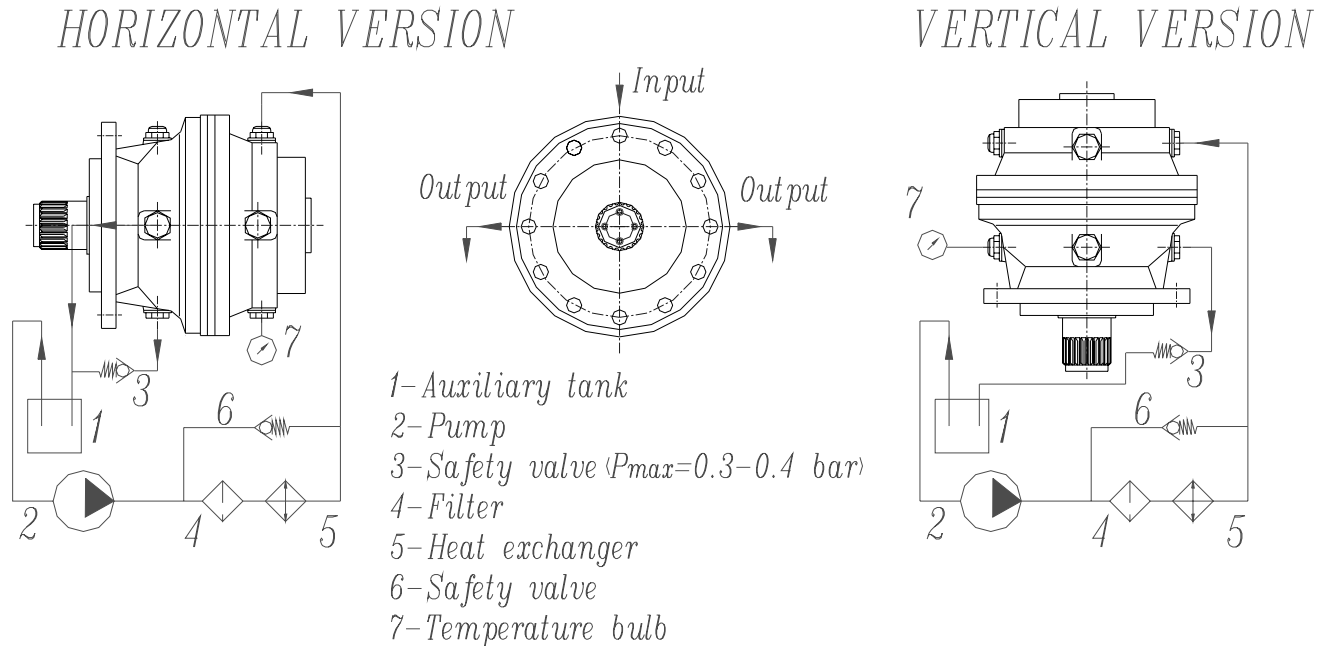

b) Maximum torque

Make sure that the maximum torque (considered as instantaneous load peak torque or starting torque under load) does not exceed the M_{2max} value that the gearbox can withstand. (Refer to the technical data tables concerning the gearboxes sizes.)

c) Radial loads

Check that radial loads exerted on input and output shafts are lower than or equal to values indicated in the tables on gearbox technical features or charts for each gearbox size. In case they are greater the indicated value, change either gearbox output version, gearbox size or system bearing arrangement.

To check proceed as follows:

Define radial loads Rc_1 at input and Rc_2 at output.

$$Rc_1 = 2000 \times Mc_1 \times Kr_1 / d_1 \quad (F18)$$

$$Rc_2 = 2000 \times Mc_2 \times Kr_2 / d_2 \quad (F19)$$

In which:

Mc_1, Mc_2 ----- Input and output calculated torque (N.m)

d_1, d_2 ----- Diameter of the part fitted onto the shaft (mm), pulley, gear or chain crown.

Kr_1, Kr_2 ----- Stress factor for radial load with following values

Chain crown ----- 1.0

Gear ----- 1.25

Belt pulley ----- 1.5-2.5

Define the trust load position X onto shaft. Check this value with the chart indicating the load Rx1 and Rx2 bearable by the gearbox. Check that the following is satisfied:

$$RC_1 \leq Rx_1 \times f_{h1} \quad (F20)$$

$$RC_2 \leq Rx_2 \times f_{h2} \quad (F21)$$

Where f_{h1} and f_{h2} the radial and thrust load corrective factor depending on the required life factor F_{h1} and F_{h2} .

d) **Thrust loads**

check the thrust load, when exerted onto the output shaft, as specified for the radial load. The following should be satisfied:

$$\pm Ac_2 \leq \pm An_2 \times f_{h2} \quad (F22)$$

when a thrust load is combined with an axial load contact Ningbo planetary gearbox sales department.

13. HOW TO SELECT THE MOTOR

Electric motor

a) n_2 and dynamic efficiency η_d are known, calculate input power based on torque M_{r2} as follows:

$$P_{r1} = (M_{r2} \times n_2) / (9549 \times \eta_d) \quad \text{KW} \quad (F23)$$

Table (2) on page 6 reports the values of efficiency η_d related to the different reduction stages of the gearboxes.

b) Look up the motor selection charts and select a size with such rated power to satisfy this condition:

$$P_{r1} \leq P_n \quad (F24)$$

4-pole motor and over should be preferred.

Unless otherwise specified, power P_n of motors indicated in the catalogue refers to continuous duty S1.

For motors used in conditions other than S1, the type of duty required by reference to CEI 2-3/IEC 34-1 Standards must be mentioned.

For duties from S2 to S8 in particular and for motor frame 132 or smaller, extra power can be obtained with respect to continuous duty power, consequently the following condition must be satisfied:

$$P_{r1}/f_m \leq P_n \quad (F25)$$

The increased power factor f_m can be obtained from table (5).

Table 5:

fm	Duty						
	S2			S3*			S4-S8
	Cycle duration (min ⁻¹)			Cyclic duration factor % (I) % (I) = $t_f / (t_f + t_r) \times 100\%$ (t_f : operating time under load) (t_r : rest time)			Please contact us Brown Group.
10	30	60	25%	40%	60%		
1.35	1.15	60	1.25	1.15	1.1		

***Cycle duration, in any event, must be 10 minutes or less. If it is longer, please contact Brown Group Spain technical service department.**

For duties other than S1 with considerable number of starts per hour, factor Z must be considered (it is ascertained by using the information in the motors chapter). Factor Z defines the maximum number of starts for the application under consideration.

c) For the output speed n_2 or closest to, select the gear motor that yields a safety factor S meeting the following condition: $S \geq f_s \quad (F26)$

Hydraulic motor

Determine hydraulic motor type according the application, choosing from the options given in guidance table (6).

Table 6:

Duty	Light		Medium		Heavy	
Pressure (bar)	<175		175-200		200-450	
Motor design	Orbital	Gear motor	Radial piston	Axial piston	Came motor	Axial piston
Speed (rpm)	Mean <=700	High <=3000	Mean <=500	High <=4000	Low <=200	Mean <=4000
η_{mh}	0.80	0.85	0.95	0.93	0.93	0.93
η_v	0.90	0.87	0.95	0.95	0.95	0.95

Based on the specifications of gearbox input:

Input torque ----- M_{r1} (N.m)

Input speed----- n_1 (min^{-1})

And on allowed pressure P (bar) for the hydraulic circuit, calculate the displacement of the hydraulic motor by formula:

$$V_c = (20 \times \pi \times M_{r1}) / (P \times \eta_{mh}) \quad \text{cm}^3 \quad (\text{F27})$$

Where η_{mh} is the hydraulic mechanical efficiency of the motor (Table 6).

Select a motor size with displacement V that satisfies the following condition:

$$V_c \leq V \quad (\text{F28})$$

Calculate the flow required for the hydraulic motor

$$Q_1 = (V \times n_1) / \eta_v \times 1000 \quad (\text{l/min}^{-1}) \quad (\text{F29})$$

Where η_v is the volumetric efficiency of the motor (Table 6).

14. INSTALLATION

Observing a few rules for correct installation is essential to the reliable and proper operation of the gearbox or gear motor.

The rules set out here are intended as a preliminary guide to selecting gearbox or gear motor. For effective and proper installation, follow the instructions given in the installation, use the maintenances manual for the gearbox available from our sales department.

Following is a brief outline of installation rules:

a) Fastening:

Place gearbox on a surface providing adequate rigidity. Mating surfaces should be machined and flat.

Mating surfaces must be within definite geometric tolerances (see manual). This is especially true of flange-mounted gearboxes with splined hollow shafts.

In applications that involve high radial loads at the output end, flange mounting is recommended for some gearbox sizes as this mounting makes use of the double pilot diameters provided in these gearboxes.

Make sure the gearbox is suitable for the required mounting position.

Use screws of resistance class 8.8 and over to secure the gearbox. Torque up screws to the figures indicated in the relevant tables.

With transmitted output torque greater than or equal 70% of the indicated M_{2max} torque, and with frequent movement reversals, use screws with minimum resistance 10.9.

Some gearbox sizes can be fastened using either screws or pins. Of pin seated in the frame the gearboxes be at least 1.5 times pin diameter.

b) Connections

Secure the connection parts to gearbox input and output. Do not tap them with hammers or similar tools. To insert these parts, use the service screws and threaded holes provided on the shafts. Be sure to clean off any grease or protects from the shafts before fitting any connection parts.

Fitting hydraulic motors.

Be careful the O ring between motor flange and gearbox input flange when assembling. Install the hydraulic motor before filling lube oil into the gearbox.

Connecting the hydraulic brake.

The hydraulic circuit should be such to ensure that brake is released instants before gearbox starts and applied after gearbox has stopped. Check that pressure in the hydraulic line for brake release is at zero whenever gearbox is stopped.

Direction of rotation

Motors are connected to the suitable electric or hydraulic circuit according to their direction of rotation. When performing these connections, bear in mind that all gearboxes, whether in the in-line or right angle design, have the same direction of rotation both at input and output. For more details of the connection of electric and hydraulic motors, see relevant sections in this catalogue.

c) Connections

Painted with antioxidant water primer in the colour red. Mating surfaces are not painted. Final coat is to be applied by the customer. Before painting, protect the seal rings installed on the shafts. Contact with paint may deteriorate the seals with subsequent oil leakage.

d) Connections

Before start-up, fill the gearbox with the recommended lube oil up to correct level. Level is checked through the suitable plug or sight glass provided on each gearbox depending on designated mounting position

15. MAINTENANCE

Gearboxes are virtually maintenance free under normal operating conditions. The only periodic operations required are checks on oil level and oil changes as follows:

Oil Changes

Change the oil first after 100-150 hours operation.

Subsequently, change the oil only every 2000-3000 hours operation depending on application. Alternatively change oil once a year.

Check the oil level in the gearbox every month and top up as necessary.

16. STORAGE

Observe the following instructions to ensure correct storage of delivered products:

- a) Do not store outdoors, in areas exposed to weather or with excessive humidity;
- b) Always place boards in wood or other material between floor and products, to avoid direct contact with the floor;
- c) For storage periods of over 60 days, all machined surfaces such as flanges, shafts and couplings must be protected with a suitable ant oxidation product (SHELL ENSIS FLUID SDC or equivalent product);
- d) The following measures must be taken in respect of products for which the expected storage period

exceeds 6 months:

d1)Cover outer machined parts and mating parts with grease to avoid oxidation;

d2)Position the gearboxes with the breather plug up and fill them with oil (this does not apply to life-lubed gearboxes). Before use, the gearboxes should be filled with the proper amount lubricant of the recommended type

17. SUPPLY CONDITIONS

Gearboxes are supplied as follows:

- a) ready for installation in the mounting position specified on order;
- b) dry; inner parts are protected by a film of the oil used for final testing;
- c) painted with antioxidant water primer in the color red, Mating surfaces are not painted and are covered with a film or protective oil. Final coats to be applied by the Customer;
- d) tested to in-house specifications;
- e) suitably packed;
- f) complete with mounting nuts and bolts for IEC electric motors;

1.0 INTRODUCTION

The EP300 series consist of a range of multi-purpose planetary gearboxes that can be operated by either hydraulic or electric motors. Basic features are:

- ! 12 sizes
- ! output torque up to 160 000 N.m
- ! transmissible power up to 250 KW
- ! ratios from 3.5:1 to 3 000:1
- ! versions: in-line and right angle (first stage with bevel gear pair Gleason)
- ! reduction stages ranging from 1 to 4
- ! with flange-mounted, foot-mounted and shaft-mounted output
- ! output shafts with keyway, splined, splined hollow shafts, hollow shafts for shaft-mounting with shrink disc
- ! input adaptors for: electric motors to IEC standards design B5 or NEMA standard, hydraulic motors by major manufactures and according to SAE J744C, negative hydraulic parking brakes for operation by hydraulic motors
- ! output shaft accessories: flanges, pinions, splined bars, shrink discs
- ! high radial and axial load capacity of output shafts thanks to tapered roller bearings fitted on the HZ and PC versions
- ! high efficiency
- ! housing made of spheroidal cast iron.

2.0 CONSTRUCTION VERSIONS

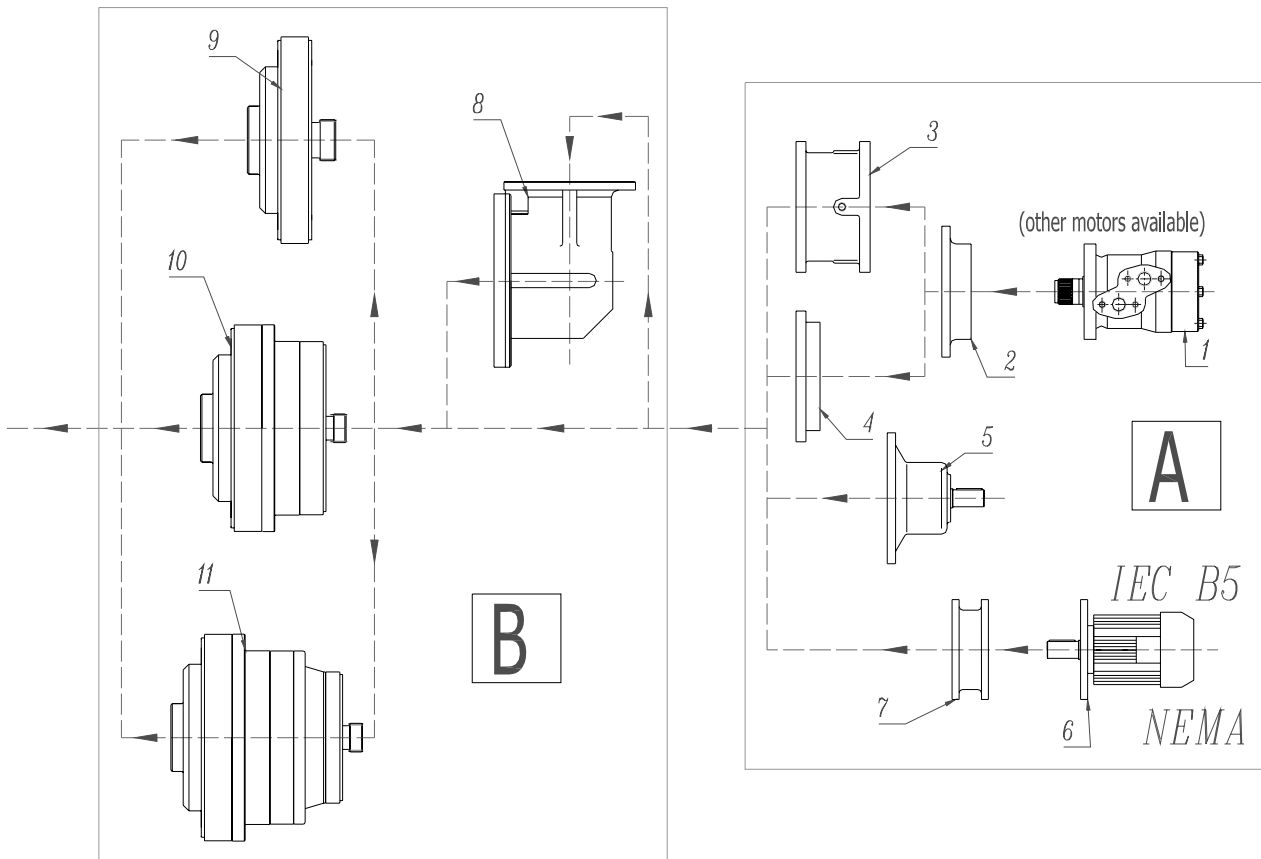

2.0 CONSTRUCTION VERSIONS

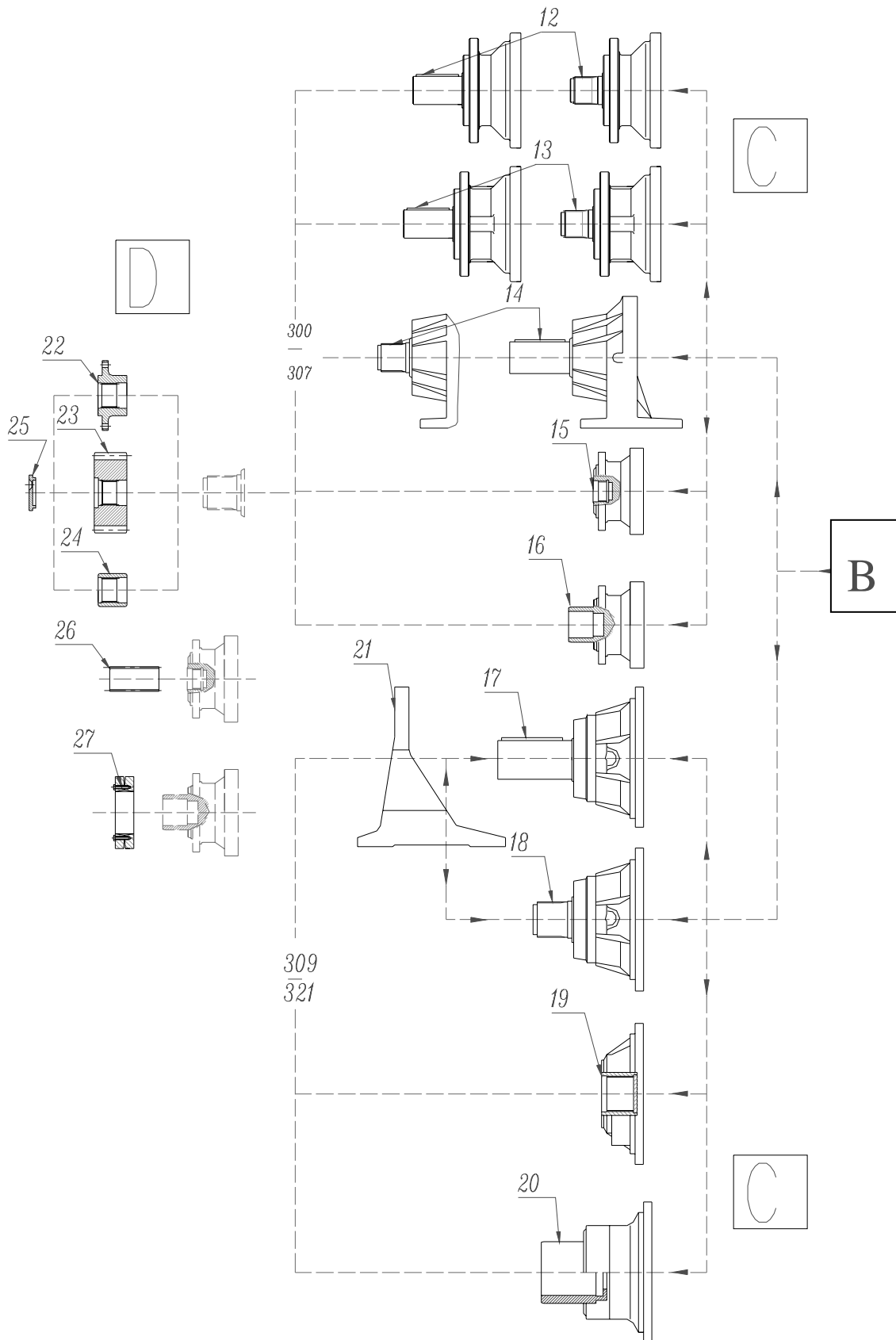

A: INPUT

1. Hydraulic motor
2. Hydraulic motor setting
3. Negative brake
4. Cover
5. Input shaft
6. Electric motor
7. Electric motor setting

B: REDUCTIONS

8. Right-angle reduction stage
9. Single planetary reduction stage
10. Two or more planetary reduction stages
11. Three or more planetary reduction stages

C: OUTPUT

12. Keyed or splined solid shaft output
13. Keyed or splined heavy solid shaft output
14. Output with support bracket and keyed or splined solid shaft
15. Splined hollow shaft output
16. Hollow shaft output for shrink disc
17. Keyed solid shaft output
18. Splined solid shaft output
19. Splined hollow shaft output
20. Hollow shaft output for shrink disc
21. Support bracket

D: FITTINGS

22. Flange
23. Pinion
24. Sleeve coupling
25. Stop bottom plate
26. Splined bar
27. Shrink disc

3.0 MOUNTING POSITION

For a proper designation of the geared motor or gearbox, mounting position please refer to the table (7) to determine mounting position.

Table 7: (in - line)

<p><i>B3</i></p> 	<p><i>B6</i></p> 	
<p><i>B7</i></p> 	<p><i>B8</i></p> 	
<p><i>V5</i></p> 	<p><i>V6</i></p> 	<p><i>V1</i></p> 
<p><i>B5</i></p> 		<p><i>V3</i></p> 

Table 7: (right angle)



4.0 LUBRICATION

(Prior to start-up)

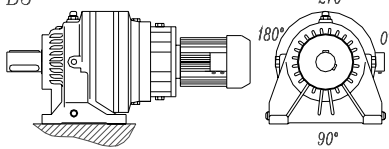
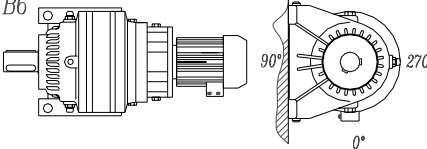
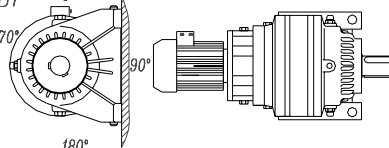
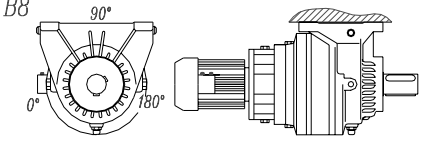
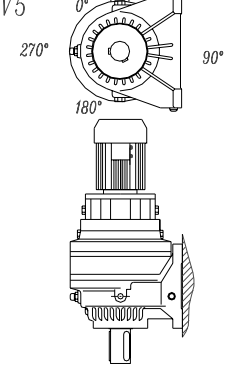
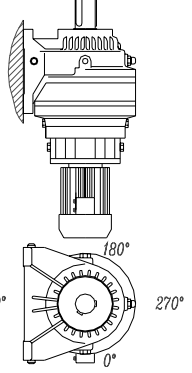
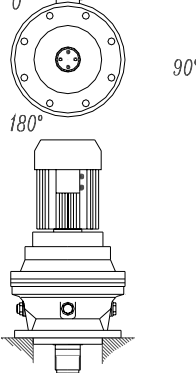
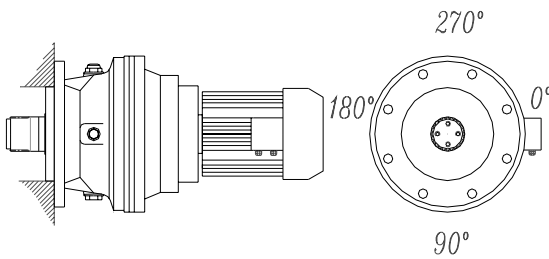
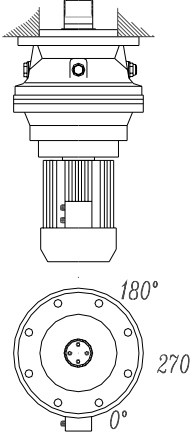
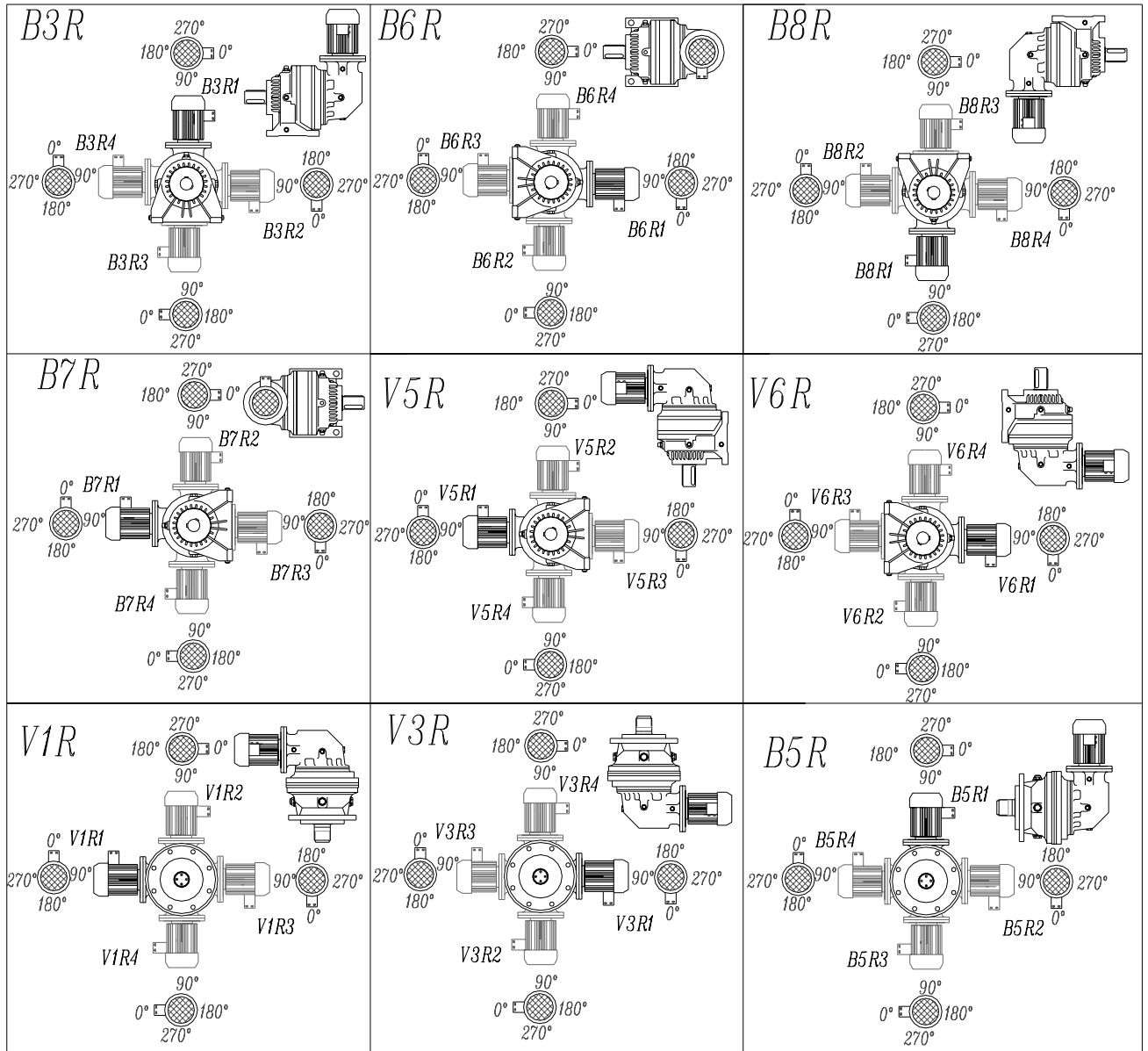
Standard lubrication is oil bath. Respect the specifications given below for fixed and mobile machines:

- 1) Mobile machinery: SAE 80W/90 oil with API GL5 properties
- 2) Industrial machinery: ISO VG 150 oils with E.P. properties

The following table lists the most common brands of lubricant and the types recommended for normal applications.

Table 8:

	INDUSTRIAL PLANTS INDUSTRIEANGEN		MOBLE MACHINES	
	ISO standard···E.P. grade		SAE standard···APL GL grade	
Ambient	-10° C /+30° C	+20° C/+45° C	-10° C/+30° C	+20° C/+45° C
	ISO VG 150	ISO VG 220	SAE 80W/90	SAE 85W/140
AGIP	BLASIA 150	BLASIA 220	ROTRA MP	ROTRA MP
ARAL	DEGOL BG 150	DEGOL BG 220	GETRIEBEOL HYP	GETRIEBEOL HYP
BP - MACH	ENERGOL GR XP 150	ENERGOL GR XP 220	HYPOGEAR EP	HYPOGEAR EP
CASTROL	ALPHA SP 150	ALPHA SP 220	HYPOY	HYPOY
CHEVRON	EDWN.L. GEAR COMPOUND 150	N.L. GEAR COMPOUND 220	UNIVERSAL GEAR	UNIVERSAL GEAR
ELF	REDUCTELF SP 150	REDUCTELF SP 220	TRANSELF8	TRANSELF8
ESSO	SPARTAN EP 150	SPARTAN EP 220	GEAR OIL GX	GEAR OIL GX
FINA	GIRAN 150	GIRAN 220		
I.P.	MELLANA 150	MELLANA 220	PONTIAX HD	PONTIAX HD
KLÜBER	LAMORA 150	LAMORA 220		
MOBIL	MOBIL GEAR 629	MOBIL GEAR 630	MOBILUBE HD	MOBILUBE HD
SHELL	OMALA EP 150	OMALA EP 220	SPIRAX HD	SPIRAX HD
TOTAL	CARTER EP 150	CARTER EP 220	TRANSMISSION TM	TRANSMISSION TM

Note:

1, For particular applications like: high temperature running conditions, non inflammable oil, etc.

contact Brown Group Spain technical Departments.

2, Maximum operating oil temperature must never exceed 85° C.

BRAKES LUBRICATION

The hydraulically operated multi disc brakes are lubricated by the same oil as the gearbox.

FILLING

Gearboxes are supplied without oil. All gearboxes are equipped with filler, lever, breather, and drain plugs. To fill the gearbox secure it in its exact working position, unscrew the oil filler plug, and add oil until it is visible in the level window. The position of the window will obviously depend on whether the unit is mounted horizontally or vertically. To drain, remove the magnetic drain plug and drain off oil. If possible, drain while the oil is hot and remove the filler plug from the top of the gearbox to give optimum oil flow.

Note: In gearboxes with brakes, brake lubrication is provided by the gearbox lubricant.

5.0 PLUG POSITIONS:

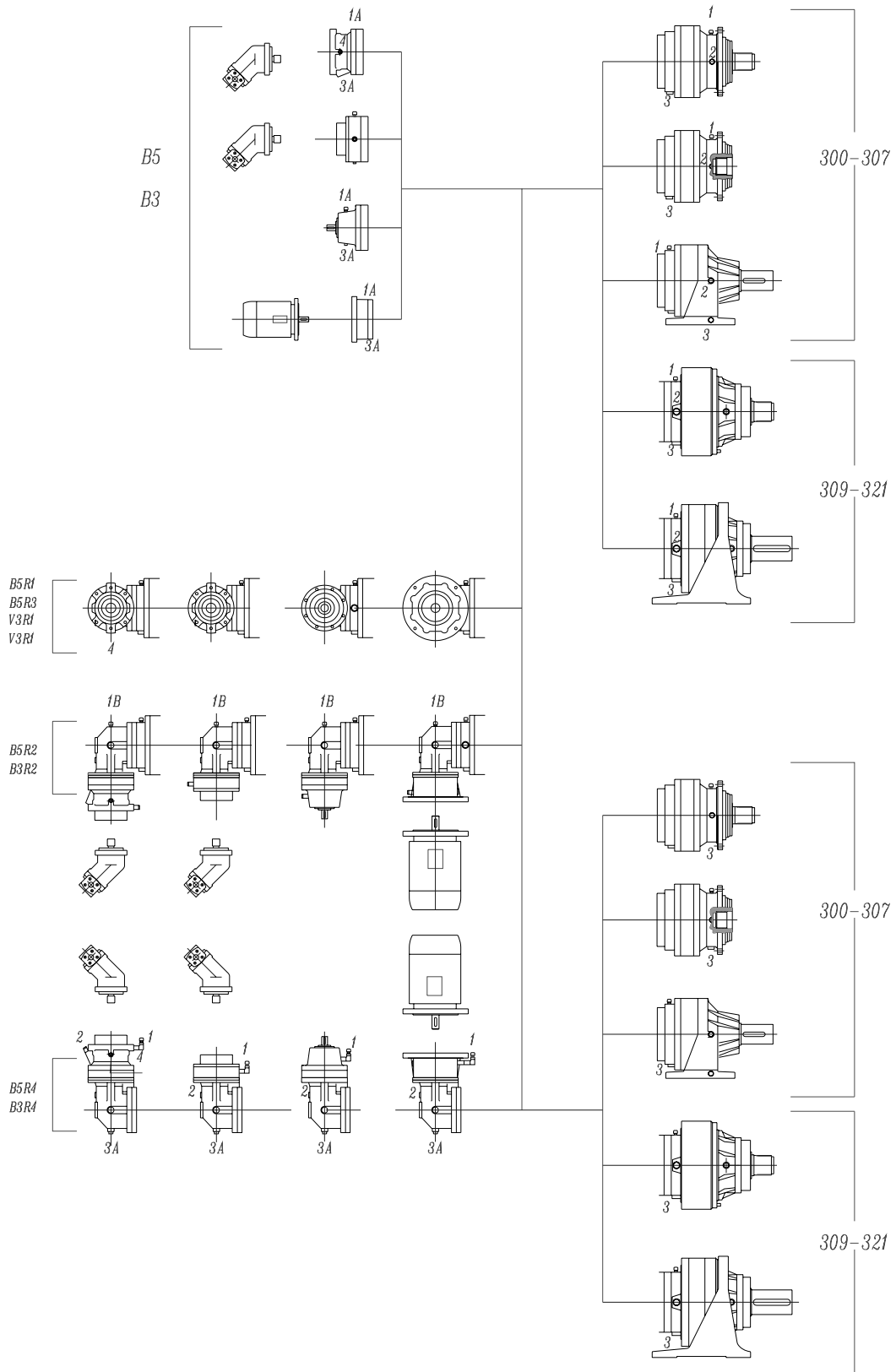

- 1, 1A, 1B: Filling/breather oil plug
- 2, 2A: Oil level plug
- 3, 3A: Oil draining plug
- 4: Brake port

PLUG POSITIONS

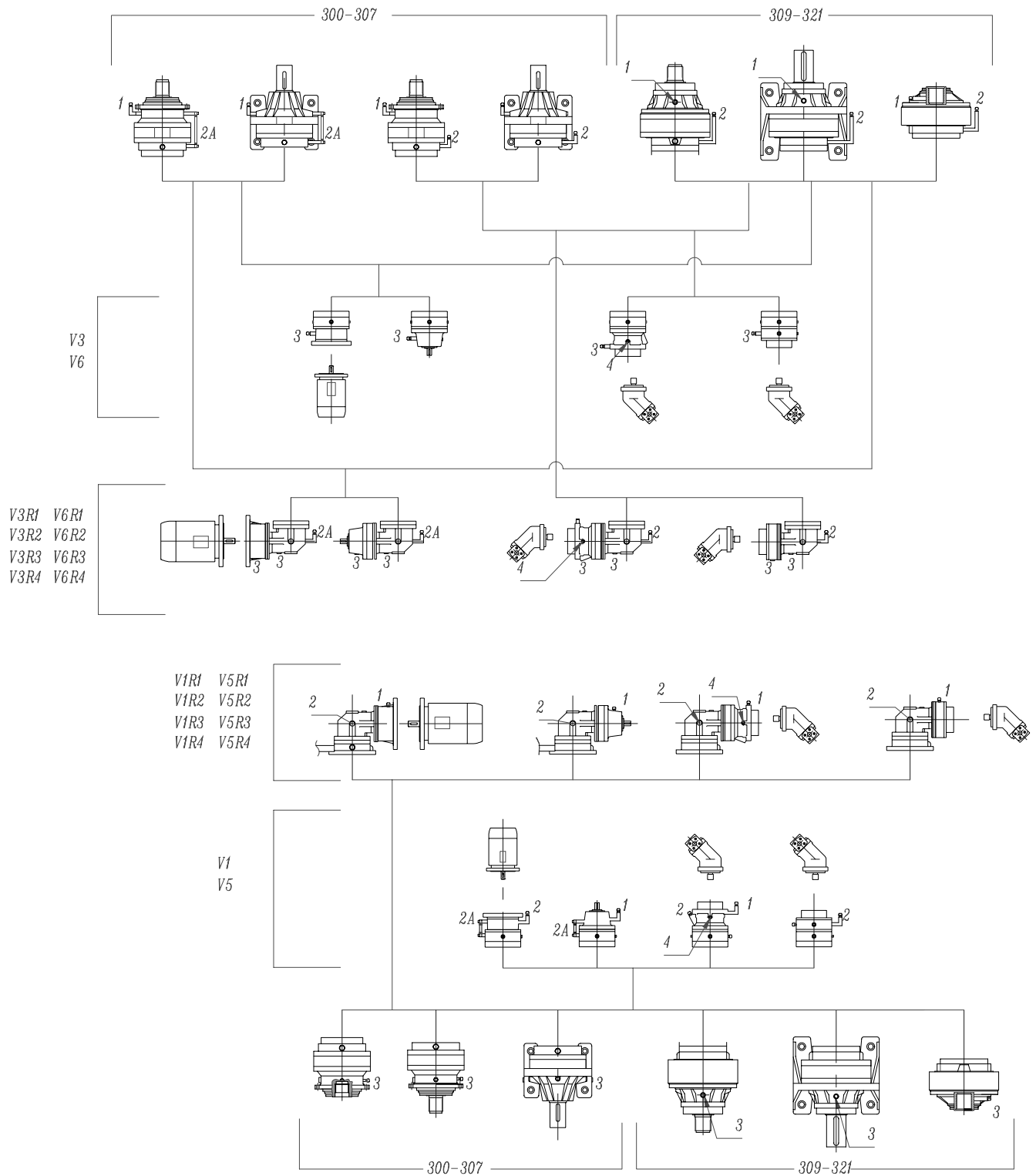

1, 1A, 1B: Filling/breather oil plug

2, 2A: Oil level plug

3, 3A: Oil draining plug

4: Brake port

6.0 REFERENCE OIL QUANTITY: ` (L)

Table 9:

TYPE		In – Line			TYPE		Right angle		
		Mounting position					Mounting position		
		B5,B3	V1,V5	V3,V6			B5R,B3R	V1R,V5R	V3R,V6R
300	L1	0.6	1.0	0.9	300	R2	1.2	1.7	1.5
	L2	0.9	1.3	1.2		R3	1.5	2.0	1.8
	L3	1.2	1.6	1.5		R4	1.8	2.3	2.1
	L4	1.5	1.9	1.8					
301	L1	0.8	1.2	1.1	301	R2	1.6	2.1	1.9
	L2	1.1	1.5	1.4		R3	1.9	2.4	2.2
	L3	1.4	1.8	1.7		R4	2.2	2.7	2.5
	L4	1.7	2.1	2.0					
303	L1	1.3	2.3	2.0	303	R2	2.2	2.8	2.6
	L2	1.6	2.6	2.3		R3	2.5	3.1	2.9
	L3	1.9	2.9	2.6		R4	2.8	3.4	3.2
	L4	2.2	3.2	2.9					
305	L1	1.6	2.6	2.4	305	R2	2.5	3.1	2.9
	L2	2.1	3.1	2.9		R3	3.0	3.6	3.4
	L3	2.4	3.4	3.2		R4	3.3	3.0	3.7
	L4	2.7	3.7	3.5					
306	L1	2.5	3.5	3.2	306	R2	4.0	5.0	4.8
	L2	3.3	4.3	4.0		R3	4.8	5.8	5.6
	L3	3.6	4.6	4.3		R4	5.1	6.1	5.9
	L4	3.9	4.9	4.6					
307	L1	3.5	5.0	4.5	307	R2	6.0	8.0	7.0
	L2	4.5	6.0	5.5		R3	7.0	9.0	8.0
	L3	5.0	6.5	6.0		R4	7.5	9.5	8.5
	L4	5.3	6.8	6.3					
309	L1	4.0	5.5	5.0	309	R2	6.5	8.5	7.5
	L2	5.0	6.5	6.0		R3	7.5	9.5	8.5
	L3	5.5	7.0	6.5		R4	8.0	10	9
	L4	5.8	7.3	6.8					
310	L1	5.0	6.5	6.0	310	R2	10	12	11
	L2	6.3	7.8	7.3		R3	11	13	12
	L3	7.1	8.6	8.1		R4	12	14	13
	L4	7.4	8.9	8.4					
311	L1	7.0	12	10	311	R2	14	19	17
	L2	9.0	14	12		R3	16	21	19
	L3	10	15	13		R4	17	22	20
	L4	10.5	15.5	13.5					
313	L1	9.0	14	12	313	R2	16	21	19
	L2	11.5	16.5	14.5		R3	19	24	22
	L3	12.5	17.5	15.5		R4	20	25	23
	L4	13	18	16					
315	L1	15	23	19	315	R3	27	35	31
	L2	19	27	23		R4	30	38	34
	L3	21	29	25					
	L4	22	30	26					
316	L1	18	26	22	316	R3	30	38	34
	L2	22	30	26		R4	33	41	37
	L3	24	32	28					
	L4	25	33	29					
317	L1	20	35	30	317	R3	38	52	48
	L2	26	41	36		R4	42	56	52
	L3	29	44	39					
	L4	30	45	40					
318	L1	25	40	35	318	R4	48	63	58
	L2	35	50	45					
	L3	40	55	50					
	L4	43	58	53					

8.0 PRODUCT IDENTIFICATION SCHEME

EP3 05 L 1-30-HZ-4F-OMP315A-B3-P-R...

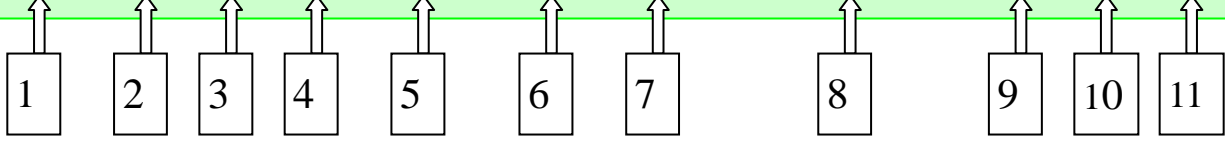

- 1 Produce series:** EP3—Planetary drives
 EP4—Track drives
 EP6—Wheel drives
 EP7—Slewing drives

- 2 Gearbox size:** 00,01,03,05...16

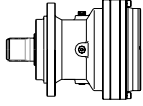
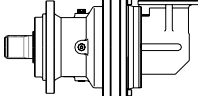
- 3 Design:** L—Liner gearbox 
 R—Right angle 

- 4 No. of reductions:** 1,2,3,4

- 5 Reduction ratio:** Fill in the value of the transm. ratio (including point and decimals) reported in the selection charts

- 6 Output version:**

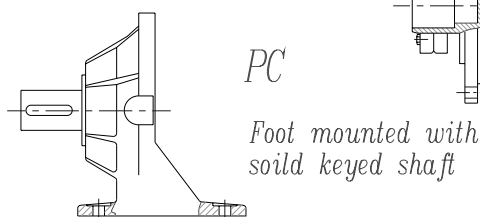
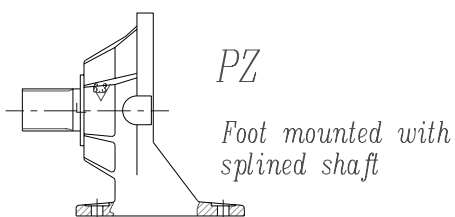
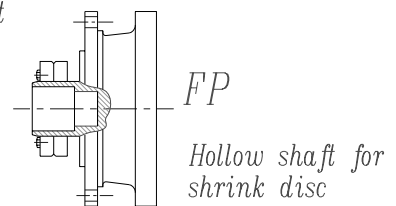
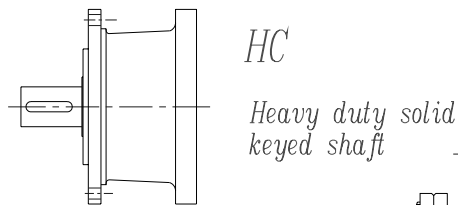
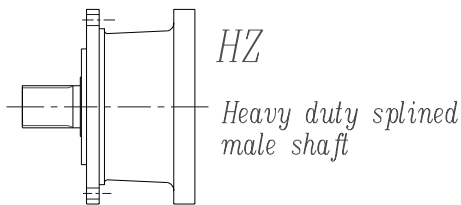
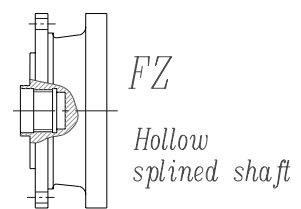
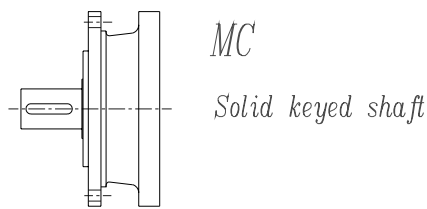
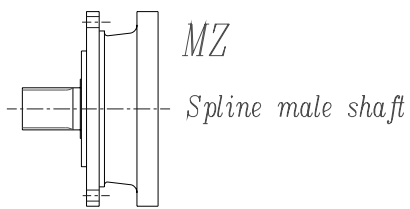

PRODUCT IDENTIFICATION SCHEME

7 Hydraulic brake type(only with hydraulic motor adaptor):

Standard negative multi disc brake: 4A,4B...4L,5B,5C...5K,6B,6C...6L (see page 24)

Without hydraulic brake: WO

8 Input:

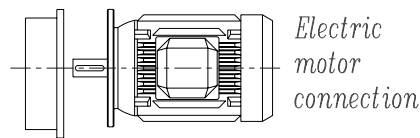
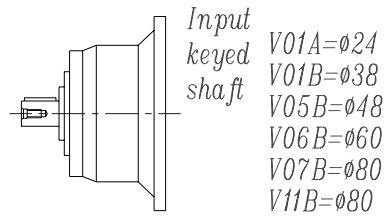

Motor size:(IEC71B5,IEC80B5...)

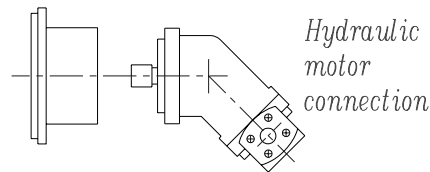

Motor size and shaft type,flange
type:(OMP315A,EPMZ50014B1...)

9 Mounting position: See page 18,19

10 Output fittings:

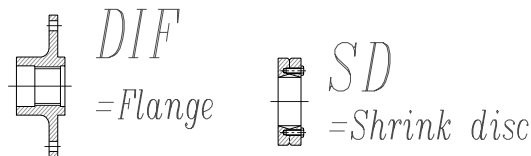

PRODUCT IDENTIFICATION SCHEME

11 Rotate direction (only for right angle design):

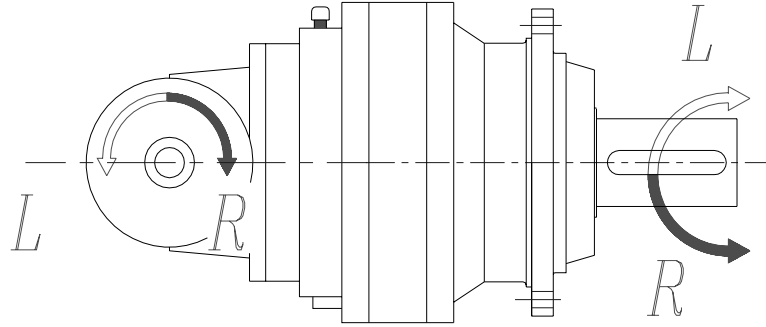

..... Option:

supplementary coolings system, etc...

EP300 series gear motor

P1=0.12 KW n1=1400 min⁻¹

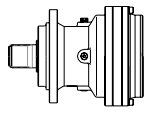
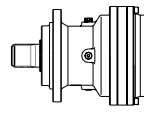
n ₂ (min ⁻¹)	M ₂ (N.m)	S	I 1:	P _t (KW)			IEC Motor type	Check Thermal Power Pt >= P1	Dimension Page Number
0.55	1833	1.06	2545	6.0	EP303L4	--	631-4	OK	PAGE 100
0.55	1833	1.89	2545	6.0	EP305L4	--	631-4	OK	PAGE 110
0.65	1551	1.06	2153	6.0	EP301L4	--	631-4	OK	PAGE 90
0.75	1344	1.52	1866	6.0	EP303L4	--	631-4	OK	PAGE 100
0.75	1344	2.80	1866	6.0	EP305L4	--	631-4	OK	PAGE 110
0.81	1243	1.29	1725	6.0	EP301L4	--	631-4	OK	PAGE 90
0.84	1195	1.67	1659	6.0	EP301L4	--	631-4	OK	PAGE 90
0.94	1077	2.27	1495	6.0	EP303L4	--	631-4	OK	PAGE 100
1.0	996	1.52	1383	6.0	EP301L4	--	631-4	OK	PAGE 90
1.1	957	0.98	1329	6.0	EP300L4	--	631-4	OK	PAGE 80
1.1	957	2.05	1329	6.0	EP301L4	--	631-4	OK	PAGE 90
1.1	905	3.03	1256	6.0	EP303L4	--	631-4	OK	PAGE 100
1.3	798	0.91	1108	6.0	EP300L4	--	631-4	OK	PAGE 80
1.3	798	1.89	1108	6.0	EP301L4	--	631-4	OK	PAGE 90
1.4	738	1.29	1024	6.0	EP300L4	--	631-4	OK	PAGE 80
1.4	738	2.65	1024	6.0	EP301L4	--	631-4	OK	PAGE 90
1.6	615	1.59	853	6.0	EP300L4	--	631-4	OK	PAGE 80
1.6	615	3.18	853	6.0	EP301L4	--	631-4	OK	PAGE 90
1.8	562	1.74	780	6.0	EP300L4	--	631-4	OK	PAGE 80
1.8	562	3.41	780	6.0	EP301L4	--	631-4	OK	PAGE 90
1.8	551	1.06	765	10.0	--	EP300R4	631-4	OK	PAGE 80
1.8	551	2.05	765	10.0	--	EP301R4	631-4	OK	PAGE 90
1.9	522	3.26	725	12.0	--	EP303R4	631-4	OK	PAGE 100
2.2	468	1.97	650	6.0	EP300L4	--	631-4	OK	PAGE 80
2.2	450	2.05	625	6.0	EP300L4	--	631-4	OK	PAGE 80
2.3	442	1.59	613	10.0	--	EP300R4	631-4	OK	PAGE 80
2.3	442	3.26	613	10.0	--	EP301R4	631-4	OK	PAGE 90
2.8	361	2.50	501	6.0	EP300L4	--	631-4	OK	PAGE 80
2.9	343	2.65	476	6.0	EP300L4	--	631-4	OK	PAGE 80
3.0	340	2.80	472	10.0	--	EP300R4	631-4	OK	PAGE 80
3.7	273	3.18	378	10.0	--	EP300R4	631-4	OK	PAGE 80
3.8	278	1.98	373	7.5	EP300L3	--	631-4	OK	PAGE 80
4.7	223	2.78	299	7.5	EP300L3	--	631-4	OK	PAGE 80

EP300 series gear motor

P1=0.18 KW n1=1400 min⁻¹

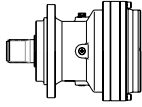
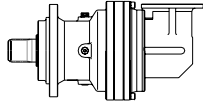
n₂ (min ⁻¹)	M₂ (N.m)	S	I 1:	P_t (KW)			IEC Motor type	Check Thermal Power Pt >= P1	Dimension Page Number
0.55	2749	1.26	2545	6.0	EP305L4	--	632-4	OK	PAGE 110
0.56	2708	2.53	2506	6.0	EP306L4	--	632-4	OK	PAGE 120
0.68	2209	3.54	2045	6.0	EP306L4	--	632-4	OK	PAGE 120
0.75	2016	1.01	1866	6.0	EP303L4	--	632-4	OK	PAGE 100
0.75	2016	1.87	1866	6.0	EP305L4	--	632-4	OK	PAGE 110
0.81	1864	0.86	1725	6.0	EP301L4	--	632-4	OK	PAGE 90
0.84	1792	1.11	1659	6.0	EP301L4	--	632-4	OK	PAGE 90
0.94	1616	1.52	1495	6.0	EP303L4	--	632-4	OK	PAGE 100
0.94	1616	2.78	1495	6.0	EP305L4	--	632-4	OK	PAGE 110
1.0	1494	1.01	1383	6.0	EP301L4	--	632-4	OK	PAGE 90
1.1	1436	1.36	1329	6.0	EP301L4	--	632-4	OK	PAGE 90
1.1	1357	2.02	1256	6.0	EP303L4	--	632-4	OK	PAGE 100
1.3	1197	1.26	1108	6.0	EP301L4	--	632-4	OK	PAGE 90
1.4	1106	0.86	1024	6.0	EP300L4	--	632-4	OK	PAGE 80
1.4	1106	1.77	1024	6.0	EP301L4	--	632-4	OK	PAGE 90
1.4	1087	2.53	1007	6.0	EP303L4	--	632-4	OK	PAGE 100
1.6	922	1.06	853	6.0	EP300L4	--	632-4	OK	PAGE 80
1.6	922	2.12	853	6.0	EP301L4	--	632-4	OK	PAGE 90
1.7	871	3.03	806	6.0	EP303L4	--	632-4	OK	PAGE 100
1.8	843	1.16	780	6.0	EP300L4	--	632-4	OK	PAGE 80
1.8	843	2.27	780	6.0	EP301L4	--	632-4	OK	PAGE 90
1.8	827	1.36	765	10.0	--	EP301R4	632-4	OK	PAGE 90
1.9	805	3.28	745	6.0	EP303L4	--	632-4	OK	PAGE 100
1.9	783	2.17	725	12.0	--	EP303R4	632-4	OK	PAGE 100
2.2	702	1.31	650	6.0	EP300L4	--	632-4	OK	PAGE 80
2.2	702	2.68	650	6.0	EP301L4	--	632-4	OK	PAGE 90
2.2	675	1.36	625	6.0	EP300L4	--	632-4	OK	PAGE 80
2.2	675	2.78	625	6.0	EP301L4	--	632-4	OK	PAGE 90
2.3	662	1.06	613	10.0	--	EP300R4	632-4	OK	PAGE 80
2.3	662	2.17	613	10.0	--	EP301R4	632-4	OK	PAGE 90
2.6	574	3.03	531	12.0	--	EP303R4	632-4	OK	PAGE 100
2.8	541	1.67	501	6.0	EP300L4	--	632-4	OK	PAGE 80
2.8	541	3.28	501	6.0	EP301L4	--	632-4	OK	PAGE 90
2.9	514	1.77	476	6.0	EP300L4	--	632-4	OK	PAGE 80
2.9	514	3.43	476	6.0	EP301L4	--	632-4	OK	PAGE 90
3.0	510	1.87	472	10.0	--	EP300R4	632-4	OK	PAGE 80
3.0	510	3.38	472	10.0	--	EP301R4	632-4	OK	PAGE 90
3.7	409	2.12	378	10.0	--	EP300R4	632-4	OK	PAGE 80
3.8	417	1.32	373	7.5	EP300L3	--	632-4	OK	PAGE 80
3.8	417	2.69	373	7.5	EP301L3	--	632-4	OK	PAGE 90
4.7	334	1.86	299	7.5	EP300L3	--	632-4	OK	PAGE 80
4.8	315	2.78	292	10.0	--	EP300R4	632-4	OK	PAGE 80
6.0	252	3.33	234	10.0	--	EP300R4	632-4	OK	PAGE 80

EP300 series gear motor

P1=0.25KW n1=1400 min⁻¹

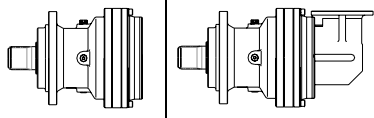
n ₂ (min ⁻¹)	M ₂ (N.m)	S	I 1:	P _t (KW)			IEC Motor type	Check Thermal Power Pt >= P1	Dimension Page Number
					EP305L4	EP303L4			
0.55	3819	0.91	2545	6.0	EP305L4	--	711-4	OK	PAGE 110
0.56	3761	1.82	2506	6.0	EP306L4	--	711-4	OK	PAGE 120
0.64	3305	2.91	2202	7.5	EP307L4	--	711-4	OK	PAGE 130
0.68	3069	2.55	2045	6.0	EP306L4	--	711-4	OK	PAGE 120
0.75	2800	1.35	1866	6.0	EP305L4	--	711-4	OK	PAGE 110
0.84	2508	2.91	1671	6.0	EP306L4	--	711-4	OK	PAGE 120
0.94	2244	1.09	1495	6.0	EP303L4	--	711-4	OK	PAGE 100
0.94	2244	2.00	1495	6.0	EP305L4	--	711-4	OK	PAGE 110
1.05	2009	3.49	1339	6.0	EP306L4	--	711-4	OK	PAGE 120
1.1	1995	0.98	1329	6.0	EP301L4	--	711-4	OK	PAGE 90
1.1	1885	1.45	1256	6.0	EP303L4	--	711-4	OK	PAGE 100
1.1	1885	2.55	1256	6.0	EP305L4	--	711-4	OK	PAGE 110
1.3	1662	0.91	1108	6.0	EP301L4	--	711-4	OK	PAGE 90
1.4	1537	1.27	1024	6.0	EP301L4	--	711-4	OK	PAGE 90
1.4	1510	1.82	1007	6.0	EP303L4	--	711-4	OK	PAGE 100
1.6	1281	1.53	853	6.0	EP301L4	--	711-4	OK	PAGE 90
1.7	1210	2.18	806	6.0	EP303L4	--	711-4	OK	PAGE 100
1.8	1170	1.64	780	6.0	EP301L4	--	711-4	OK	PAGE 90
1.8	1148	0.98	765	10.0	--	EP301R4	711-4	OK	PAGE 90
1.9	1118	2.36	745	6.0	EP303L4	--	711-4	OK	PAGE 100
1.9	1087	1.56	725	12.0	--	EP303R4	711-4	OK	PAGE 100
1.9	1087	2.73	725	12.0	--	EP305R4	711-4	OK	PAGE 110
2.2	975	0.95	650	6.0	EP300L4	--	711-4	OK	PAGE 80
2.2	975	1.93	650	6.0	EP301L4	--	711-4	OK	PAGE 90
2.2	938	0.98	625	6.0	EP300L4	--	711-4	OK	PAGE 80
2.2	938	2.00	625	6.0	EP301L4	--	711-4	OK	PAGE 90
2.3	932	2.55	621	6.0	EP303L4	--	711-4	OK	PAGE 100
2.3	920	1.56	613	10.0	--	EP301R4	711-4	OK	PAGE 90
2.6	797	2.18	531	12.0	--	EP303R4	711-4	OK	PAGE 100
2.8	751	1.20	501	6.0	EP300L4	--	711-4	OK	PAGE 80
2.8	751	2.36	501	6.0	EP301L4	--	711-4	OK	PAGE 90
2.9	714	1.27	476	6.0	EP300L4	--	711-4	OK	PAGE 80
2.9	714	2.47	476	6.0	EP301L4	--	711-4	OK	PAGE 90
3.0	710	3.27	473	6.0	EP303L4	--	711-4	OK	PAGE 100
3.0	709	1.35	472	10.0	--	EP300R4	711-4	OK	PAGE 80
3.0	709	2.44	472	10.0	--	EP301R4	711-4	OK	PAGE 90
3.3	639	3.27	426	12.0	--	EP303R4	711-4	OK	PAGE 100
3.6	579	2.91	386	6.0	EP301L4	--	711-4	OK	PAGE 90
3.7	568	1.53	378	10.0	--	EP300R4	711-4	OK	PAGE 80
3.7	568	3.09	378	10.0	--	EP301R4	711-4	OK	PAGE 90
3.8	579	0.95	373	7.5	EP300L3	--	711-4	OK	PAGE 80
3.8	579	1.93	373	7.5	EP301L3	--	711-4	OK	PAGE 90
4.0	548	2.81	353	7.5	EP303L3	--	711-4	OK	PAGE 100
4.7	464	1.34	299	7.5	EP300L3	--	711-4	OK	PAGE 80
4.8	437	2.00	292	10.0	--	EP300R4	711-4	OK	PAGE 80
6.0	351	2.40	234	10.0	--	EP300R4	711-4	OK	PAGE 80
6.1	358	2.46	230	7.5	EP300L3	--	711-4	OK	PAGE 80
6.3	333	2.55	222	10.0	--	EP300R4	711-4	OK	PAGE 80
7.6	286	2.99	185	7.5	EP300L3	--	711-4	OK	PAGE 80
7.8	270	3.09	180	10.0	--	EP300R4	711-4	OK	PAGE 80
13.2	165	3.16	106	12.0	--	EP300R3	711-4	OK	PAGE 80

EP300 series gear motor

P1=0.37KW n1=1400 min⁻¹

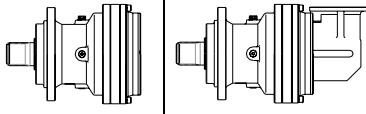
n ₂ (min ⁻¹)	M ₂ (N.m)	S	I 1:	P _t (KW)			IEC Motor type	Check Thermal Power Pt >= P1	Dimension Page Number
0.56	5566	1.23	2506	6.0	EP306L4	--	712-4	OK	PAGE 120
0.64	4891	1.97	2202	7.5	EP307L4	--	712-4	OK	PAGE 130
0.64	4891	3.44	2202	7.5	EP309L4	--	712-4	OK	PAGE 140
0.68	4542	1.72	2045	6.0	EP306L4	--	712-4	OK	PAGE 120
0.75	4145	0.91	1866	6.0	EP305L4	--	712-4	OK	PAGE 110
0.75	4121	2.46	1856	7.5	EP307L4	--	712-4	OK	PAGE 130
0.84	3711	1.97	1671	6.0	EP306L4	--	712-4	OK	PAGE 120
0.92	3367	2.95	1516	7.5	EP307L4	--	712-4	OK	PAGE 130
0.94	3321	1.35	1495	6.0	EP305L4	--	712-4	OK	PAGE 110
1.05	2974	2.36	1339	6.0	EP306L4	--	712-4	OK	PAGE 120
1.1	2790	0.98	1256	6.0	EP303L4	--	712-4	OK	PAGE 100
1.1	2790	1.72	1256	6.0	EP305L4	--	712-4	OK	PAGE 110
1.2	2669	2.70	1202	6.0	EP306L4	--	712-4	OK	PAGE 120
1.4	2279	3.44	1026	6.0	EP306L4	--	712-4	OK	PAGE 120
1.4	2274	0.86	1024	6.0	EP301L4	--	712-4	OK	PAGE 90
1.4	2235	1.23	1007	6.0	EP303L4	--	712-4	OK	PAGE 100
1.4	2235	2.46	1007	6.0	EP305L4	--	712-4	OK	PAGE 110
1.6	1895	1.03	853	6.0	EP301L4	--	712-4	OK	PAGE 90
1.7	1791	1.47	806	6.0	EP303L4	--	712-4	OK	PAGE 100
1.7	1791	2.95	806	6.0	EP305L4	--	712-4	OK	PAGE 110
1.8	1732	1.11	780	6.0	EP301L4	--	712-4	OK	PAGE 90
1.9	1654	1.60	745	6.0	EP303L4	--	712-4	OK	PAGE 100
1.9	1654	3.19	745	6.0	EP305L4	--	712-4	OK	PAGE 110
1.9	1609	1.06	725	12.0	--	EP303R4	712-4	OK	PAGE 100
1.9	1609	1.84	725	12.0	--	EP305R4	712-4	OK	PAGE 110
2.2	1443	1.30	650	6.0	EP301L4	--	712-4	OK	PAGE 90
2.2	1388	1.35	625	6.0	EP301L4	--	712-4	OK	PAGE 90
2.3	1380	1.72	621	6.0	EP303L4	--	712-4	OK	PAGE 100
2.3	1362	1.06	613	10.0	--	EP301R4	712-4	OK	PAGE 90
2.6	1180	1.47	531	12.0	--	EP303R4	712-4	OK	PAGE 100
2.6	1180	2.95	531	12.0	--	EP305R4	712-4	OK	PAGE 110
2.8	1112	1.60	501	6.0	EP301L4	--	712-4	OK	PAGE 90
2.9	1057	0.86	476	6.0	EP300L4	--	712-4	OK	PAGE 80
2.9	1057	1.67	476	6.0	EP301L4	--	712-4	OK	PAGE 90
3.0	1051	2.21	473	6.0	EP303L4	--	712-4	OK	PAGE 100
3.0	1049	0.91	472	10.0	--	EP300R4	712-4	OK	PAGE 80
3.0	1049	1.65	472	10.0	--	EP301R4	712-4	OK	PAGE 90
3.3	946	2.21	426	12.0	--	EP303R4	712-4	OK	PAGE 100
3.4	917	2.46	413	6.0	EP303L4	--	712-4	OK	PAGE 100
3.6	857	1.97	386	6.0	EP301L4	--	712-4	OK	PAGE 90
3.7	840	1.03	378	10.0	--	EP300R4	712-4	OK	PAGE 80
3.7	840	2.09	378	10.0	--	EP301R4	712-4	OK	PAGE 90
3.8	857	1.31	373	7.5	EP301L3	--	712-4	OK	PAGE 90
3.8	809	2.95	364	6.0	EP303L4	--	712-4	OK	PAGE 100
3.9	794	3.19	358	12.0	--	EP303R4	712-4	OK	PAGE 100
4.0	812	1.90	353	7.5	EP303L3	--	712-4	OK	PAGE 100
4.4	707	3.19	318	6.0	EP303L4	--	712-4	OK	PAGE 100
4.7	687	0.90	299	7.5	EP300L3	--	712-4	OK	PAGE 80
4.7	687	2.38	299	7.5	EP301L3	--	712-4	OK	PAGE 90
4.7	660	2.46	297	6.0	EP301L4	--	712-4	OK	PAGE 90
4.8	647	1.35	292	10.0	--	EP300R4	712-4	OK	PAGE 80

EP300 series gear motor

P1=0.37KW n1=1400 min⁻¹

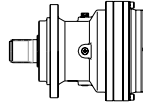
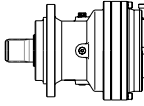
n₂ (min ⁻¹)	M₂ (N.m)	S	I 1:	P_t (KW)			IEC Motor type	Check Thermal Power Pt >= P1	Dimension Page Number
4.8	647	2.70	292	10.0	--	EP301R4	712-4	OK	PAGE 90
5.4	595	2.85	259	7.5	EP303L3	--	712-4	OK	PAGE 100
6.0	519	1.62	234	10.0	--	EP300R4	712-4	OK	PAGE 80
6.0	519	3.19	234	10.0	--	EP301R4	712-4	OK	PAGE 90
6.1	529	1.66	230	7.5	EP300L3	--	712-4	OK	PAGE 80
6.1	529	3.09	230	7.5	EP301L3	--	712-4	OK	PAGE 90
6.3	493	1.72	222	10.0	--	EP300R4	712-4	OK	PAGE 80
6.3	493	3.44	222	10.0	--	EP301R4	712-4	OK	PAGE 90
7.6	424	2.02	185	7.5	EP300L3	--	712-4	OK	PAGE 80
7.8	400	2.09	180	10.0	--	EP300R4	712-4	OK	PAGE 80
9.8	327	2.61	142	7.5	EP300L3	--	712-4	OK	PAGE 80
10.3	301	2.70	135	10.0	--	EP300R4	712-4	OK	PAGE 80
12.3	262	3.09	114	7.5	EP300L3	--	712-4	OK	PAGE 80
12.9	249	3.33	108	7.5	EP300L3	--	712-4	OK	PAGE 80
13.2	244	2.14	106	12.0	--	EP300R3	712-4	OK	PAGE 80
16.4	196	3.09	85.2	12.0	--	EP300R3	712-4	OK	PAGE 80

EP300 series gear motor

P1=0.55KW n1=1400 min⁻¹

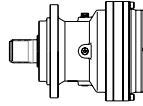
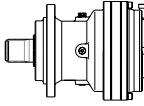
n₂ (min ⁻¹)	M₂ (N.m)	S	I 1:	P_t (KW)			IEC Motor type	Check Thermal Power Pt >= P1	Dimension Page Number
0.59	7835	2.98	2373	11.0	EP310L4	--	801-4	OK	PAGE 150
0.64	7270	1.32	2202	7.5	EP307L4	--	801-4	OK	PAGE 130
0.64	7270	2.31	2202	7.5	EP309L4	--	801-4	OK	PAGE 140
0.68	6751	1.16	2045	6.0	EP306L4	--	801-4	OK	PAGE 120
0.75	6126	1.65	1856	7.5	EP307L4	--	801-4	OK	PAGE 130
0.75	6126	2.64	1856	7.5	EP309L4	--	801-4	OK	PAGE 140
0.84	5517	1.32	1671	6.0	EP306L4	--	801-4	OK	PAGE 120
0.92	5006	1.98	1516	7.5	EP307L4	--	801-4	OK	PAGE 130
0.92	5006	3.47	1516	7.5	EP309L4	--	801-4	OK	PAGE 140
0.94	4937	0.91	1495	6.0	EP305L4	--	801-4	OK	PAGE 110
1.05	4420	1.59	1339	6.0	EP306L4	--	801-4	OK	PAGE 120
1.1	4147	1.16	1256	6.0	EP305L4	--	801-4	OK	PAGE 110
1.2	4011	2.81	1215	7.5	EP307L4	--	801-4	OK	PAGE 130
1.2	4011	2.81	1215	7.5	EP307L4	--	801-4	OK	PAGE 130
1.2	3967	1.82	1202	6.0	EP306L4	--	801-4	OK	PAGE 120
1.3	3600	3.31	1090	7.5	EP307L4	--	801-4	OK	PAGE 130
1.4	3388	2.31	1026	6.0	EP306L4	--	801-4	OK	PAGE 120
1.4	3323	1.65	1007	6.0	EP305L4	--	801-4	OK	PAGE 110
1.7	2715	2.81	822	6.0	EP306L4	--	801-4	OK	PAGE 120
1.7	2662	0.99	806	6.0	EP303L4	--	801-4	OK	PAGE 100
1.7	2662	1.98	806	6.0	EP305L4	--	801-4	OK	PAGE 110

EP300 series gear motor

P1=0.55KW n1=1400 min⁻¹

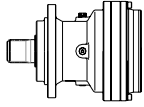
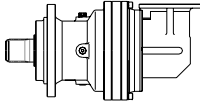
n ₂ (min ⁻¹)	M ₂ (N.m)	S	I 1:	P _t (KW)			IEC Motor type	Check Thermal	Dimension
								Power Pt >= P1	Page Number
1.9	2459	1.07	745	6.0	EP303L4	--	801-4	OK	PAGE 100
1.9	2459	2.15	745	6.0	EP305L4	--	801-4	OK	PAGE 110
1.9	2392	1.24	725	12.0	--	EP305R4	801-4	OK	PAGE 110
2.0	2356	2.48	714	12.0	--	EP306R4	801-4	OK	PAGE 120
2.2	2146	0.88	650	6.0	EP301L4	--	801-4	OK	PAGE 90
2.2	2063	0.91	625	6.0	EP301L4	--	801-4	OK	PAGE 90
2.3	2051	1.16	621	6.0	EP303L4	--	801-4	OK	PAGE 100
2.3	2051	2.48	621	6.0	EP305L4	--	801-4	OK	PAGE 110
2.4	1922	3.31	582	12.0	--	EP306R4	801-4	OK	PAGE 120
2.6	1754	0.99	531	12.0	--	EP303R4	801-4	OK	PAGE 100
2.6	1754	1.98	531	12.0	--	EP305R4	801-4	OK	PAGE 110
2.8	1653	1.07	501	6.0	EP301L4	--	801-4	OK	PAGE 90
2.9	1571	1.12	476	6.0	EP301L4	--	801-4	OK	PAGE 90
3.0	1562	1.49	473	6.0	EP303L4	--	801-4	OK	PAGE 100
3.0	1562	3.31	473	6.0	EP305L4	--	801-4	OK	PAGE 110
3.0	1559	1.11	472	10.0	--	EP301R4	801-4	OK	PAGE 90
3.3	1406	1.49	426	12.0	--	EP303R4	801-4	OK	PAGE 100
3.3	1406	3.14	426	12.0	--	EP305R4	801-4	OK	PAGE 110
3.4	1364	1.65	413	6.0	EP303L4	--	801-4	OK	PAGE 100
3.6	1273	1.32	386	6.0	EP301L4	--	801-4	OK	PAGE 90
3.7	1249	1.40	378	10.0	--	EP301R4	801-4	OK	PAGE 90
3.8	1274	0.88	373	7.5	EP301L3	--	801-4	OK	PAGE 90
3.8	1203	1.98	364	6.0	EP303L4	--	801-4	OK	PAGE 100
3.9	1181	2.15	358	12.0	--	EP303R4	801-4	OK	PAGE 100
4.0	1207	1.28	353	7.5	EP303L3	--	801-4	OK	PAGE 100
4.0	1207	2.40	353	7.5	EP305L3	--	801-4	OK	PAGE 110
4.4	1050	2.15	318	6.0	EP303L4	--	801-4	OK	PAGE 100
4.7	1021	1.60	299	7.5	EP301L3	--	801-4	OK	PAGE 90
4.7	981	1.65	297	6.0	EP301L4	--	801-4	OK	PAGE 90
4.8	962	0.91	292	10.0	--	EP300R4	801-4	OK	PAGE 80
4.8	962	1.82	292	10.0	--	EP301R4	801-4	OK	PAGE 90
4.9	946	2.64	287	12.0	--	EP303R4	801-4	OK	PAGE 100
5.0	916	2.48	278	6.0	EP303L4	--	801-4	OK	PAGE 100
5.4	885	1.92	259	7.5	EP303L3	--	801-4	OK	PAGE 100
6.0	771	1.09	234	10.0	--	EP300R4	801-4	OK	PAGE 80
6.0	771	2.15	234	10.0	--	EP301R4	801-4	OK	PAGE 90
6.1	787	1.12	230	7.5	EP300L3	--	801-4	OK	PAGE 80
6.1	787	2.08	230	7.5	EP301L3	--	801-4	OK	PAGE 90
6.3	733	1.16	222	10.0	--	EP300R4	801-4	OK	PAGE 80
6.3	733	2.31	222	10.0	--	EP301R4	801-4	OK	PAGE 90
6.3	729	3.31	221	12.0	--	EP303R4	801-4	OK	PAGE 100
6.7	709	2.88	208	7.5	EP303L3	--	801-4	OK	PAGE 100
7.6	630	1.36	185	7.5	EP300L3	--	801-4	OK	PAGE 80
7.6	630	2.56	185	7.5	EP301L3	--	801-4	OK	PAGE 90
7.8	594	1.40	180	10.0	--	EP300R4	801-4	OK	PAGE 80
7.8	594	2.81	180	10.0	--	EP301R4	801-4	OK	PAGE 90
9.8	486	1.76	142	7.5	EP300L3	--	801-4	OK	PAGE 80
9.8	486	3.20	142	7.5	EP301L3	--	801-4	OK	PAGE 90
10.3	447	1.82	135	10.0	--	EP300R4	801-4	OK	PAGE 80
12.3	389	2.08	114	7.5	EP300L3	--	801-4	OK	PAGE 80
12.9	370	2.24	108	7.5	EP300L3	--	801-4	OK	PAGE 80

EP300 series gear motor

P1=0.55KW n1=1400 min⁻¹

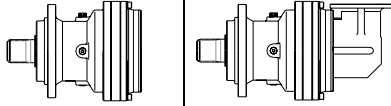
n ₂ (min ⁻¹)	M ₂ (N.m)	S	I 1:	P _t (KW)			IEC Motor type	Check Thermal Power Pt >= P1	Dimension Page Number
13.2	363	1.44	106	12.0	--	EP300R3	801-4	OK	PAGE 80
13.2	363	3.04	106	12.0	--	EP301R3	801-4	OK	PAGE 90
13.4	345	2.31	104	10.0	--	EP300R4	801-4	OK	PAGE 80
15.9	300	2.72	87.8	7.5	EP300L3	--	801-4	OK	PAGE 80
16.4	291	2.08	85.2	12.0	--	EP300R3	801-4	OK	PAGE 80
17.6	262	2.98	79.5	10.0	--	EP300R4	801-4	OK	PAGE 80
27.0	183	2.94	51.8	7.5	EP300L2	--	801-4	OK	PAGE 80

EP300 series gear motor

P1=0.75KW n1=1400 min⁻¹

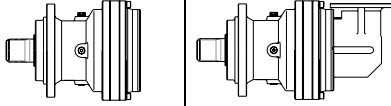
n ₂ (min ⁻¹)	M ₂ (N.m)	S	I 1:	P _t (KW)			IEC Motor type	Check Thermal Power Pt >= P1	Dimension Page Number
0.59	10684	2.18	2373	11.0	EP310L4	--	802-4	OK	PAGE 150
0.64	9914	0.97	2202	7.5	EP307L4	--	802-4	OK	PAGE 130
0.64	9914	1.70	2202	7.5	EP309L4	--	802-4	OK	PAGE 140
0.68	9206	0.85	2045	6.0	EP306L4	--	802-4	OK	PAGE 120
0.72	8718	2.67	1937	11.0	EP310L4	--	802-4	OK	PAGE 150
0.75	8353	1.21	1856	7.5	EP307L4	--	802-4	OK	PAGE 130
0.75	8353	1.94	1856	7.5	EP309L4	--	802-4	OK	PAGE 140
0.84	7523	0.97	1671	6.0	EP306L4	--	802-4	OK	PAGE 120
0.88	7124	3.03	1582	11.0	EP310L4	--	802-4	OK	PAGE 150
0.92	6826	1.45	1516	7.5	EP307L4	--	802-4	OK	PAGE 130
0.92	6826	2.55	1516	7.5	EP309L4	--	802-4	OK	PAGE 140
1.05	6028	1.16	1339	6.0	EP306L4	--	802-4	OK	PAGE 120
1.1	5655	0.85	1256	6.0	EP305L4	--	802-4	OK	PAGE 110
1.2	5470	2.06	1215	7.5	EP307L4	--	802-4	OK	PAGE 130
1.2	5470	2.06	1215	7.5	EP307L4	--	802-4	OK	PAGE 130
1.2	5470	3.03	1215	7.5	EP309L4	--	802-4	OK	PAGE 140
1.2	5409	1.33	1202	6.0	EP306L4	--	802-4	OK	PAGE 120
1.3	4909	2.42	1090	7.5	EP307L4	--	802-4	OK	PAGE 130
1.3	4909	3.27	1090	7.5	EP309L4	--	802-4	OK	PAGE 140
1.4	4620	1.70	1026	6.0	EP306L4	--	802-4	OK	PAGE 120
1.4	4531	1.21	1007	6.0	EP305L4	--	802-4	OK	PAGE 110
1.5	4114	2.67	914	7.5	EP307L4	--	802-4	OK	PAGE 130
1.7	3702	2.06	822	6.0	EP306L4	--	802-4	OK	PAGE 120
1.7	3631	1.45	806	6.0	EP305L4	--	802-4	OK	PAGE 110
1.8	3456	3.15	768	7.5	EP307L4	--	802-4	OK	PAGE 130
1.9	3353	1.58	745	6.0	EP305L4	--	802-4	OK	PAGE 110
1.9	3291	2.91	731	6.0	EP306L4	--	802-4	OK	PAGE 120
1.9	3262	0.91	725	12.0	--	EP305R4	802-4	OK	PAGE 110
2.0	3212	1.82	714	12.0	--	EP306R4	802-4	OK	PAGE 120
2.2	2823	3.03	627	14.0	--	EP307R4	802-4	OK	PAGE 130
2.3	2797	0.85	621	6.0	EP303L4	--	802-4	OK	PAGE 100
2.3	2797	1.82	621	6.0	EP305L4	--	802-4	OK	PAGE 110
2.4	2637	3.52	586	6.0	EP306L4	--	802-4	OK	PAGE 120
2.4	2621	2.42	582	12.0	--	EP306R4	802-4	OK	PAGE 120

EP300 series gear motor

P1=0.75KW n1=1400 min⁻¹

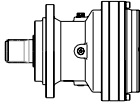
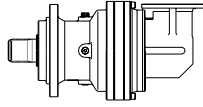
n₂ (min ⁻¹)	M₂ (N.m)	S	I 1:	P_t (KW)			IEC Motor type	Check Thermal Power Pt >= P1	Dimension Page Number
2.6	2392	1.45	531	12.0	--	EP305R4	802-4	OK	PAGE 110
2.9	2142	2.91	476	12.0	--	EP306R4	802-4	OK	PAGE 120
3.0	2130	1.09	473	6.0	EP303L4	--	802-4	OK	PAGE 100
3.0	2130	2.42	473	6.0	EP305L4	--	802-4	OK	PAGE 110
3.3	1917	1.09	426	12.0	--	EP303R4	802-4	OK	PAGE 100
3.3	1917	2.30	426	12.0	--	EP305R4	802-4	OK	PAGE 110
3.4	1859	1.21	413	6.0	EP303L4	--	802-4	OK	PAGE 100
3.4	1859	2.79	413	6.0	EP305L4	--	802-4	OK	PAGE 110
3.6	1736	0.97	386	6.0	EP301L4	--	802-4	OK	PAGE 90
3.7	1716	3.52	381	12.0	--	EP306R4	802-4	OK	PAGE 120
3.7	1704	1.03	378	10.0	--	EP301R4	802-4	OK	PAGE 90
3.8	1641	1.45	364	6.0	EP303L4	--	802-4	OK	PAGE 100
3.8	1641	3.15	364	6.0	EP305L4	--	802-4	OK	PAGE 110
3.9	1610	1.58	358	12.0	--	EP303R4	802-4	OK	PAGE 100
3.9	1610	3.15	358	12.0	--	EP305R4	802-4	OK	PAGE 110
4.0	1645	0.94	353	7.5	EP303L3	--	802-4	OK	PAGE 100
4.0	1645	1.76	353	7.5	EP305L3	--	802-4	OK	PAGE 110
4.0	1620	3.28	348	7.5	EP306L3	--	802-4	OK	PAGE 120
4.4	1432	1.58	318	6.0	EP303L4	--	802-4	OK	PAGE 100
4.7	1392	1.17	299	7.5	EP301L3	--	802-4	OK	PAGE 90
4.7	1338	1.21	297	6.0	EP301L4	--	802-4	OK	PAGE 90
4.8	1312	1.33	292	10.0	--	EP301R4	802-4	OK	PAGE 90
4.9	1290	1.94	287	12.0	--	EP303R4	802-4	OK	PAGE 100
5.0	1250	1.82	278	6.0	EP303L4	--	802-4	OK	PAGE 100
5.4	1207	1.41	259	7.5	EP303L3	--	802-4	OK	PAGE 100
5.4	1207	2.81	259	7.5	EP305L3	--	802-4	OK	PAGE 110
6.0	1052	1.58	234	10.0	--	EP301R4	802-4	OK	PAGE 90
6.1	1073	1.52	230	7.5	EP301L3	--	802-4	OK	PAGE 90
6.3	1000	0.85	222	10.0	--	EP300R4	802-4	OK	PAGE 80
6.3	1000	1.70	222	10.0	--	EP301R4	802-4	OK	PAGE 90
6.3	994	2.42	221	12.0	--	EP303R4	802-4	OK	PAGE 100
6.7	967	2.11	208	7.5	EP303L3	--	802-4	OK	PAGE 100
7.6	859	1.00	185	7.5	EP300L3	--	802-4	OK	PAGE 80
7.6	859	1.88	185	7.5	EP301L3	--	802-4	OK	PAGE 90
7.8	810	1.03	180	10.0	--	EP300R4	802-4	OK	PAGE 80
7.8	810	2.06	180	10.0	--	EP301R4	802-4	OK	PAGE 90
8.0	812	3.05	174	7.5	EP303L3	--	802-4	OK	PAGE 100
8.3	757	3.15	168	12.0	--	EP303R4	802-4	OK	PAGE 100
9.8	662	1.29	142	7.5	EP300L3	--	802-4	OK	PAGE 80
9.8	662	2.34	142	7.5	EP301L3	--	802-4	OK	PAGE 90
10.3	610	1.33	135	10.0	--	EP300R4	802-4	OK	PAGE 80
10.3	610	2.67	135	10.0	--	EP301R4	802-4	OK	PAGE 90
12.3	531	1.52	114	7.5	EP300L3	--	802-4	OK	PAGE 80
12.3	531	2.81	114	7.5	EP301L3	--	802-4	OK	PAGE 90
12.9	504	1.64	108	7.5	EP300L3	--	802-4	OK	PAGE 80
12.9	504	2.93	108	7.5	EP301L3	--	802-4	OK	PAGE 90
13.2	495	1.05	106	12.0	--	EP300R3	802-4	OK	PAGE 80
13.2	495	2.23	106	12.0	--	EP301R3	802-4	OK	PAGE 90
13.4	470	1.70	104	10.0	--	EP300R4	802-4	OK	PAGE 80
13.4	470	3.27	104	10.0	--	EP301R4	802-4	OK	PAGE 90
15.9	409	1.99	87.8	7.5	EP300L3	--	802-4	OK	PAGE 80

EP300 series gear motor

P1=0.75KW n1=1400 min⁻¹

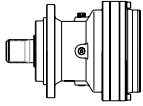
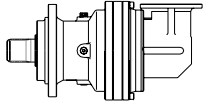
n₂ (min ⁻¹)	M₂ (N.m)	S	I 1:	P_t (KW)			IEC Motor type	Check Thermal Power Pt >= P1	Dimension Page Number
16.4	396	1.52	85.2	12.0	--	EP300R3	802-4	OK	PAGE 80
16.4	396	3.16	85.2	12.0	--	EP301R3	802-4	OK	PAGE 90
17.6	358	2.18	79.5	10.0	--	EP300R4	802-4	OK	PAGE 80
21.2	308	2.58	66.1	7.5	EP300L3	--	802-4	OK	PAGE 80
21.3	305	2.58	65.6	12.0	--	EP300R3	802-4	OK	PAGE 80
26.6	245	3.16	52.6	12.0	--	EP300R3	802-4	OK	PAGE 80
27.0	249	2.16	51.8	7.5	EP300L2	--	802-4	OK	PAGE 80
27.5	237	3.28	50.9	7.5	EP300L3	--	802-4	OK	PAGE 80
33.7	200	3.18	41.5	7.5	EP300L2	--	802-4	OK	PAGE 80

EP300 series gear motor

P1=1.1KW n1=1400 min⁻¹

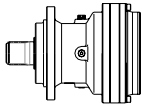
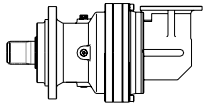
n₂ (min ⁻¹)	M₂ (N.m)	S	I 1:	P_t (KW)			IEC Motor type	Check Thermal Power Pt >= P1	Dimension Page Number
0.59	15670	1.49	2373	11.0	EP310L4	--	90S-4	OK	PAGE 150
0.64	14541	1.16	2202	7.5	EP309L4	--	90S-4	OK	PAGE 140
0.72	12786	1.82	1937	11.0	EP310L4	--	90S-4	OK	PAGE 150
0.73	12583	2.56	1906	11.0	EP311L4	--	90S-4	OK	PAGE 160
0.75	12252	1.32	1856	7.5	EP309L4	--	90S-4	OK	PAGE 140
0.87	10602	3.55	1606	11.0	EP311L4	--	90S-4	OK	PAGE 160
0.88	10448	2.07	1582	11.0	EP310L4	--	90S-4	OK	PAGE 150
0.92	10011	0.99	1516	7.5	EP307L4	--	90S-4	OK	PAGE 130
0.92	10011	1.74	1516	7.5	EP309L4	--	90S-4	OK	PAGE 140
1.0	9376	2.73	1420	11.0	EP310L4	--	90S-4	OK	PAGE 150
1.1	8372	2.48	1268	11.0	EP310L4	--	90S-4	OK	PAGE 150
1.2	8022	1.40	1215	7.5	EP307L4	--	90S-4	OK	PAGE 130
1.2	8022	1.40	1215	7.5	EP307L4	--	90S-4	OK	PAGE 130
1.2	8022	2.07	1215	7.5	EP309L4	--	90S-4	OK	PAGE 140
1.2	7934	0.91	1202	6.0	EP306L4	--	90S-4	OK	PAGE 120
1.2	7662	3.14	1160	11.0	EP310L4	--	90S-4	OK	PAGE 150
1.3	7199	1.65	1090	7.5	EP307L4	--	90S-4	OK	PAGE 130
1.3	7199	2.23	1090	7.5	EP309L4	--	90S-4	OK	PAGE 140
1.4	6776	1.16	1026	6.0	EP306L4	--	90S-4	OK	PAGE 120
1.5	6034	1.82	914	7.5	EP307L4	--	90S-4	OK	PAGE 130
1.5	6034	2.73	914	7.5	EP309L4	--	90S-4	OK	PAGE 140
1.7	5577	3.55	845	14.0	--	EP310R4	90S-4	OK	PAGE 150
1.7	5429	1.40	822	6.0	EP306L4	--	90S-4	OK	PAGE 120
1.7	5325	0.99	806	6.0	EP305L4	--	90S-4	OK	PAGE 110
1.8	5068	2.15	768	7.5	EP307L4	--	90S-4	OK	PAGE 130
1.9	4918	1.07	745	6.0	EP305L4	--	90S-4	OK	PAGE 110
1.9	4827	1.98	731	6.0	EP306L4	--	90S-4	OK	PAGE 120
2.0	4712	1.24	714	12.0	--	EP306R4	90S-4	OK	PAGE 120
2.2	4140	2.07	627	14.0	--	EP307R4	90S-4	OK	PAGE 130
2.2	4140	3.31	627	14.0	--	EP309R4	90S-4	OK	PAGE 140
2.3	4102	1.24	621	6.0	EP305L4	--	90S-4	OK	PAGE 110
2.4	3904	2.73	591	7.5	EP307L4	--	90S-4	OK	PAGE 130
2.4	3868	2.40	586	6.0	EP306L4	--	90S-4	OK	PAGE 120

EP300 series gear motor

P1=1.1KW n1=1400 min⁻¹

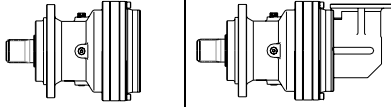
n ₂ (min ⁻¹)	M ₂ (N.m)	S	I 1:	P _t (KW)			IEC Motor type	Check Thermal Power Pt >= P1	Dimension Page Number
2.4	3844	1.65	582	12.0	--	EP306R4	90S-4	OK	PAGE 120
2.6	3508	0.99	531	12.0	--	EP305R4	90S-4	OK	PAGE 110
2.6	3488	2.73	528	14.0	--	EP307R4	90S-4	OK	PAGE 130
2.9	3141	1.98	476	12.0	--	EP306R4	90S-4	OK	PAGE 120
3.0	3129	3.31	474	7.5	EP307L4	--	90S-4	OK	PAGE 130
3.0	3124	1.65	473	6.0	EP305L4	--	90S-4	OK	PAGE 110
3.1	2980	3.14	451	6.0	EP306L4	--	90S-4	OK	PAGE 120
3.2	2850	3.31	432	14.0	--	EP307R4	90S-4	OK	PAGE 130
3.3	2811	1.57	426	12.0	--	EP305R4	90S-4	OK	PAGE 110
3.4	2727	1.90	413	6.0	EP305L4	--	90S-4	OK	PAGE 110
3.7	2517	2.40	381	12.0	--	EP306R4	90S-4	OK	PAGE 120
3.8	2407	0.99	364	6.0	EP303L4	--	90S-4	OK	PAGE 100
3.8	2407	2.15	364	6.0	EP305L4	--	90S-4	OK	PAGE 110
3.9	2361	1.07	358	12.0	--	EP303R4	90S-4	OK	PAGE 100
3.9	2361	2.15	358	12.0	--	EP305R4	90S-4	OK	PAGE 110
4.0	2413	1.20	353	7.5	EP305L3	--	90S-4	OK	PAGE 110
4.0	2377	2.24	348	7.5	EP306L3	--	90S-4	OK	PAGE 120
4.1	2259	2.64	342	12.0	--	EP306R4	90S-4	OK	PAGE 120
4.4	2101	1.07	318	6.0	EP303L4	--	90S-4	OK	PAGE 100
4.4	2101	2.40	318	6.0	EP305L4	--	90S-4	OK	PAGE 110
4.8	1925	0.91	292	10.0	--	EP301R4	90S-4	OK	PAGE 90
4.9	1892	1.32	287	12.0	--	EP303R4	90S-4	OK	PAGE 100
4.9	1892	2.73	287	12.0	--	EP305R4	90S-4	OK	PAGE 110
4.9	1939	3.36	284	7.5	EP306L3	--	90S-4	OK	PAGE 120
5.0	1833	1.24	278	6.0	EP303L4	--	90S-4	OK	PAGE 100
5.0	1833	2.73	278	6.0	EP305L4	--	90S-4	OK	PAGE 110
5.4	1770	0.96	259	7.5	EP303L3	--	90S-4	OK	PAGE 100
5.4	1770	1.92	259	7.5	EP305L3	--	90S-4	OK	PAGE 110
6.0	1542	1.07	234	10.0	--	EP301R4	90S-4	OK	PAGE 90
6.1	1573	1.04	230	7.5	EP301L3	--	90S-4	OK	PAGE 90
6.3	1466	1.16	222	10.0	--	EP301R4	90S-4	OK	PAGE 90
6.3	1458	1.65	221	12.0	--	EP303R4	90S-4	OK	PAGE 100
6.3	1458	3.31	221	12.0	--	EP305R4	90S-4	OK	PAGE 110
6.7	1418	1.44	208	7.5	EP303L3	--	90S-4	OK	PAGE 100
6.7	1418	3.04	208	7.5	EP305L3	--	90S-4	OK	PAGE 110
7.6	1260	1.28	185	7.5	EP301L3	--	90S-4	OK	PAGE 90
7.8	1188	1.40	180	10.0	--	EP301R4	90S-4	OK	PAGE 90
8.0	1191	2.08	174	7.5	EP303L3	--	90S-4	OK	PAGE 100
8.3	1110	2.15	168	12.0	--	EP303R4	90S-4	OK	PAGE 100
9.5	969	2.40	147	12.0	--	EP303R4	90S-4	OK	PAGE 100
9.8	971	0.88	142	7.5	EP300L3	--	90S-4	OK	PAGE 80
9.8	971	1.60	142	7.5	EP301L3	--	90S-4	OK	PAGE 90
10.0	954	2.56	140	7.5	EP303L3	--	90S-4	OK	PAGE 100
10.3	895	0.91	135	10.0	--	EP300R4	90S-4	OK	PAGE 80
10.3	895	1.82	135	10.0	--	EP301R4	90S-4	OK	PAGE 90
10.8	855	2.64	130	12.0	--	EP303R4	90S-4	OK	PAGE 100
12.3	778	1.04	114	7.5	EP300L3	--	90S-4	OK	PAGE 80
12.3	778	1.92	114	7.5	EP301L3	--	90S-4	OK	PAGE 90
12.4	747	2.98	113	12.0	--	EP303R4	90S-4	OK	PAGE 100
12.9	739	1.12	108	7.5	EP300L3	--	90S-4	OK	PAGE 80
12.9	739	2.00	108	7.5	EP301L3	--	90S-4	OK	PAGE 90

EP300 series gear motor

P1=1.1KW n1=1400 min⁻¹

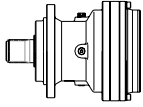
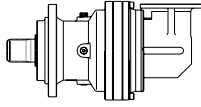
n ₂ (min ⁻¹)	M ₂ (N.m)	S	I 1:	P _t (KW)			IEC Motor type	Check Thermal	Dimension
								Power Pt >= P1	Page Number
13.0	735	3.20	108	7.5	EP303L3	--	90S-4	OK	PAGE 100
13.2	726	1.52	106	12.0	--	EP301R3	90S-4	OK	PAGE 90
13.4	689	1.16	104	10.0	--	EP300R4	90S-4	OK	PAGE 80
13.4	689	2.23	104	10.0	--	EP301R4	90S-4	OK	PAGE 90
13.9	687	2.40	101	14.0	--	EP303R3	90S-4	OK	PAGE 100
14.2	651	3.31	98.6	12.0	--	EP303R4	90S-4	OK	PAGE 100
15.9	599	1.36	87.8	7.5	EP300L3	--	90S-4	OK	PAGE 80
15.9	599	2.40	87.8	7.5	EP301L3	--	90S-4	OK	PAGE 90
16.4	581	1.04	85.2	12.0	--	EP300R3	90S-4	OK	PAGE 80
16.4	581	2.16	85.2	12.0	--	EP301R3	90S-4	OK	PAGE 90
17.0	561	2.96	82.2	14.0	--	EP303R3	90S-4	OK	PAGE 100
17.6	525	1.49	79.5	10.0	--	EP300R4	90S-4	OK	PAGE 80
17.6	525	2.89	79.5	10.0	--	EP301R4	90S-4	OK	PAGE 90
19.0	504	3.36	73.8	14.0	--	EP303R3	90S-4	OK	PAGE 100
21.2	451	1.76	66.1	7.5	EP300L3	--	90S-4	OK	PAGE 80
21.2	451	3.04	66.1	7.5	EP301L3	--	90S-4	OK	PAGE 90
21.3	448	1.76	65.6	12.0	--	EP300R3	90S-4	OK	PAGE 80
21.3	448	3.28	65.6	12.0	--	EP301R3	90S-4	OK	PAGE 90
26.6	359	2.16	52.6	12.0	--	EP300R3	90S-4	OK	PAGE 80
27.0	366	1.47	51.8	7.5	EP300L2	--	90S-4	OK	PAGE 80
27.0	366	2.79	51.8	7.5	EP301L2	--	90S-4	OK	PAGE 90
27.5	348	2.24	50.9	7.5	EP300L3	--	90S-4	OK	PAGE 80
33.7	293	2.17	41.5	7.5	EP300L2	--	90S-4	OK	PAGE 80
34.6	276	2.64	40.5	12.0	--	EP300R3	90S-4	OK	PAGE 80
36.1	265	2.80	38.8	7.5	EP300L3	--	90S-4	OK	PAGE 80
43.8	226	3.17	32.0	7.5	EP300L2	--	90S-4	OK	PAGE 80
45.4	211	3.36	30.8	12.0	--	EP300R3	90S-4	OK	PAGE 80

EP300 series gear motor

P1=1.5KW n1=1400 min⁻¹

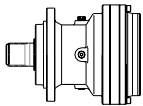
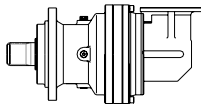
n ₂ (min ⁻¹)	M ₂ (N.m)	S	I 1:	P _t (KW)			IEC Motor type	Check Thermal	Dimension
								Power Pt >= P1	Page Number
0.59	21369	1.09	2373	11.0	EP310L4	--	90L-4	OK	PAGE 150
0.64	19828	0.85	2202	7.5	EP309L4	--	90L-4	OK	PAGE 140
0.72	17435	1.33	1937	11.0	EP310L4	--	90L-4	OK	PAGE 150
0.73	17159	1.88	1906	11.0	EP311L4	--	90L-4	OK	PAGE 160
0.75	16735	2.73	1859	11.0	EP313L4	--	90L-4	OK	PAGE 170
0.75	16707	0.97	1856	7.5	EP309L4	--	90L-4	OK	PAGE 140
0.87	14458	2.61	1606	11.0	EP311L4	--	90L-4	OK	PAGE 160
0.88	14247	1.52	1582	11.0	EP310L4	--	90L-4	OK	PAGE 150
0.89	14114	3.45	1568	11.0	EP313L4	--	90L-4	OK	PAGE 170
0.92	13652	1.27	1516	7.5	EP309L4	--	90L-4	OK	PAGE 140
1.0	12786	2.00	1420	11.0	EP310L4	--	90L-4	OK	PAGE 150
1.0	12182	3.03	1353	11.0	EP311L4	--	90L-4	OK	PAGE 160
1.1	11416	1.82	1268	11.0	EP310L4	--	90L-4	OK	PAGE 150
1.2	10939	1.03	1215	7.5	EP307L4	--	90L-4	OK	PAGE 130
1.2	10939	1.52	1215	7.5	EP309L4	--	90L-4	OK	PAGE 140

EP300 series gear motor

P1=1.5KW n1=1400 min⁻¹

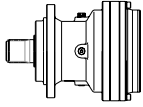
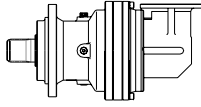
n₂ (min ⁻¹)	M₂ (N.m)	S	I 1:	P_t (KW)			IEC Motor type	Check Thermal Power Pt >= P1	Dimension Page Number
1.2	10448	2.30	1160	11.0	EP310L4	--	90L-4	OK	PAGE 150
1.3	9817	1.21	1090	7.5	EP307L4	--	90L-4	OK	PAGE 130
1.3	9817	1.64	1090	7.5	EP309L4	--	90L-4	OK	PAGE 140
1.4	9240	0.85	1026	6.0	EP306L4	--	90L-4	OK	PAGE 120
1.5	8372	2.67	930	11.0	EP310L4	--	90L-4	OK	PAGE 150
1.5	8228	1.33	914	7.5	EP307L4	--	90L-4	OK	PAGE 130
1.5	8228	2.00	914	7.5	EP309L4	--	90L-4	OK	PAGE 140
1.7	7605	2.61	845	14.0	--	EP310R4	90L-4	OK	PAGE 150
1.7	7513	2.91	834	11.0	EP310L4	--	90L-4	OK	PAGE 150
1.7	7404	1.03	822	6.0	EP306L4	--	90L-4	OK	PAGE 120
1.8	6911	1.58	768	7.5	EP307L4	--	90L-4	OK	PAGE 130
1.8	6911	2.73	768	7.5	EP309L4	--	90L-4	OK	PAGE 140
1.9	6582	1.45	731	6.0	EP306L4	--	90L-4	OK	PAGE 120
2.0	6425	0.91	714	12.0	--	EP306R4	90L-4	OK	PAGE 120
2.0	6416	3.39	713	11.0	EP310L4	--	90L-4	OK	PAGE 150
2.0	6205	3.03	689	14.0	--	EP310R4	90L-4	OK	PAGE 150
2.2	5645	1.52	627	14.0	--	EP307R4	90L-4	OK	PAGE 130
2.2	5645	2.42	627	14.0	--	EP309R4	90L-4	OK	PAGE 140
2.3	5594	0.91	621	6.0	EP305L4	--	90L-4	OK	PAGE 110
2.4	5324	2.00	591	7.5	EP307L4	--	90L-4	OK	PAGE 130
2.4	5324	3.33	591	7.5	EP309L4	--	90L-4	OK	PAGE 140
2.4	5274	1.76	586	6.0	EP306L4	--	90L-4	OK	PAGE 120
2.4	5242	1.21	582	12.0	--	EP306R4	90L-4	OK	PAGE 120
2.5	5071	3.64	563	14.0	--	EP310R4	90L-4	OK	PAGE 150
2.6	4757	2.00	528	14.0	--	EP307R4	90L-4	OK	PAGE 130
2.6	4757	2.73	528	14.0	--	EP309R4	90L-4	OK	PAGE 140
2.9	4284	1.45	476	12.0	--	EP306R4	90L-4	OK	PAGE 120
3.0	4266	2.42	474	7.5	EP307L4	--	90L-4	OK	PAGE 130
3.0	4260	1.21	473	6.0	EP305L4	--	90L-4	OK	PAGE 110
3.1	4063	2.30	451	6.0	EP306L4	--	90L-4	OK	PAGE 120
3.2	3887	2.42	432	14.0	--	EP307R4	90L-4	OK	PAGE 130
3.3	3833	1.15	426	12.0	--	EP305R4	90L-4	OK	PAGE 110
3.4	3719	1.39	413	6.0	EP305L4	--	90L-4	OK	PAGE 110
3.7	3432	1.76	381	12.0	--	EP306R4	90L-4	OK	PAGE 120
3.8	3287	3.03	365	7.5	EP307L4	--	90L-4	OK	PAGE 130
3.8	3282	1.58	364	6.0	EP305L4	--	90L-4	OK	PAGE 110
3.9	3220	1.58	358	12.0	--	EP305R4	90L-4	OK	PAGE 110
4.0	3291	0.88	353	7.5	EP305L3	--	90L-4	OK	PAGE 110
4.0	3241	1.64	348	7.5	EP306L3	--	90L-4	OK	PAGE 120
4.0	3115	3.03	346	14.0	--	EP307R4	90L-4	OK	PAGE 130
4.1	3094	2.97	344	6.0	EP306L4	--	90L-4	OK	PAGE 120
4.1	3080	1.94	342	12.0	--	EP306R4	90L-4	OK	PAGE 120
4.4	2865	1.76	318	6.0	EP305L4	--	90L-4	OK	PAGE 110
4.5	2795	3.33	310	14.0	--	EP307R4	90L-4	OK	PAGE 130
4.6	2848	2.93	306	11.0	EP307L3	--	90L-4	OK	PAGE 130
4.8	2631	2.91	292	12.0	--	EP306R4	90L-4	OK	PAGE 120
4.9	2580	0.97	287	12.0	--	EP303R4	90L-4	OK	PAGE 100
4.9	2580	2.00	287	12.0	--	EP305R4	90L-4	OK	PAGE 110
4.9	2644	2.46	284	7.5	EP306L3	--	90L-4	OK	PAGE 120
5.0	2499	0.91	278	6.0	EP303L4	--	90L-4	OK	PAGE 100
5.0	2499	2.00	278	6.0	EP305L4	--	90L-4	OK	PAGE 110

EP300 series gear motor

P1=1.5KW n1=1400 min⁻¹

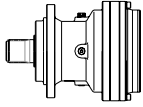
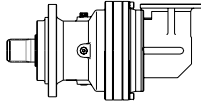
n ₂ (min ⁻¹)	M ₂ (N.m)	S	I 1:	P _t (KW)	 		IEC Motor type	Check Thermal Power Pt >= P1	Dimension Page Number
5.4	2413	1.41	259	7.5	EP305L3	--	90L-4	OK	PAGE 110
6.0	2161	2.99	232	7.5	EP306L3	--	90L-4	OK	PAGE 120
6.3	1999	0.85	222	10.0	--	EP301R4	90L-4	OK	PAGE 90
6.3	1988	1.21	221	12.0	--	EP303R4	90L-4	OK	PAGE 100
6.3	1988	2.42	221	12.0	--	EP305R4	90L-4	OK	PAGE 110
6.7	1934	1.05	208	7.5	EP303L3	--	90L-4	OK	PAGE 100
6.7	1934	2.23	208	7.5	EP305L3	--	90L-4	OK	PAGE 110
7.6	1719	0.94	185	7.5	EP301L3	--	90L-4	OK	PAGE 90
7.8	1620	1.03	180	10.0	--	EP301R4	90L-4	OK	PAGE 90
8.0	1624	1.52	174	7.5	EP303L3	--	90L-4	OK	PAGE 100
8.0	1624	2.93	174	7.5	EP305L3	--	90L-4	OK	PAGE 110
8.3	1514	1.58	168	12.0	--	EP303R4	90L-4	OK	PAGE 100
8.3	1514	2.73	168	12.0	--	EP305R4	90L-4	OK	PAGE 110
9.5	1321	1.76	147	12.0	--	EP303R4	90L-4	OK	PAGE 100
9.5	1321	3.03	147	12.0	--	EP305R4	90L-4	OK	PAGE 110
9.8	1324	1.17	142	7.5	EP301L3	--	90L-4	OK	PAGE 90
10.0	1302	1.88	140	7.5	EP303L3	--	90L-4	OK	PAGE 100
10.3	1220	1.33	135	10.0	--	EP301R4	90L-4	OK	PAGE 90
10.8	1166	1.94	130	12.0	--	EP303R4	90L-4	OK	PAGE 100
10.8	1166	3.33	130	12.0	--	EP305R4	90L-4	OK	PAGE 110
12.3	1061	1.41	114	7.5	EP301L3	--	90L-4	OK	PAGE 90
12.4	1018	2.18	113	12.0	--	EP303R4	90L-4	OK	PAGE 100
12.9	1008	1.47	108	7.5	EP301L3	--	90L-4	OK	PAGE 90
13.0	1003	2.34	108	7.5	EP303L3	--	90L-4	OK	PAGE 100
13.2	989	1.11	106	12.0	--	EP301R3	90L-4	OK	PAGE 90
13.4	940	0.85	104	10.0	--	EP300R4	90L-4	OK	PAGE 80
13.4	940	1.64	104	10.0	--	EP301R4	90L-4	OK	PAGE 90
13.9	937	1.76	101	14.0	--	EP303R3	90L-4	OK	PAGE 100
13.9	937	3.11	101	14.0	--	EP305R3	90L-4	OK	PAGE 110
14.2	888	2.42	98.6	12.0	--	EP303R4	90L-4	OK	PAGE 100
15.9	817	1.00	87.8	7.5	EP300L3	--	90L-4	OK	PAGE 80
15.9	817	1.76	87.8	7.5	EP301L3	--	90L-4	OK	PAGE 90
16.4	793	1.58	85.2	12.0	--	EP301R3	90L-4	OK	PAGE 90
17.0	766	2.17	82.2	14.0	--	EP303R3	90L-4	OK	PAGE 100
17.1	764	2.93	82.0	7.5	EP303L3	--	90L-4	OK	PAGE 100
17.6	716	1.09	79.5	10.0	--	EP300R4	90L-4	OK	PAGE 80
17.6	716	2.12	79.5	10.0	--	EP301R4	90L-4	OK	PAGE 90
19.0	687	2.46	73.8	14.0	--	EP303R3	90L-4	OK	PAGE 100
19.6	667	3.22	71.6	7.5	EP303L3	--	90L-4	OK	PAGE 100
21.2	615	1.29	66.1	7.5	EP300L3	--	90L-4	OK	PAGE 80
21.2	615	2.23	66.1	7.5	EP301L3	--	90L-4	OK	PAGE 90
21.2	613	2.64	65.9	14.0	--	EP303R3	90L-4	OK	PAGE 100
21.3	611	1.29	65.6	12.0	--	EP300R3	90L-4	OK	PAGE 80
21.3	611	2.40	65.6	12.0	--	EP301R3	90L-4	OK	PAGE 90
22.8	573	3.28	61.5	14.0	--	EP303R3	90L-4	OK	PAGE 100
23.7	551	2.81	59.1	14.0	--	EP303R3	90L-4	OK	PAGE 100
26.6	489	1.58	52.6	12.0	--	EP300R3	90L-4	OK	PAGE 80
26.6	489	2.93	52.6	12.0	--	EP301R3	90L-4	OK	PAGE 90
27.0	499	1.08	51.8	7.5	EP300L2	--	90L-4	OK	PAGE 80
27.0	499	2.04	51.8	7.5	EP301L2	--	90L-4	OK	PAGE 90
27.5	474	1.64	50.9	7.5	EP300L3	--	90L-4	OK	PAGE 80

EP300 series gear motor

P1=1.5KW n1=1400 min⁻¹

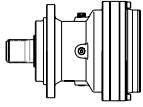
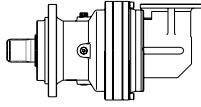
n₂ (min ⁻¹)	M₂ (N.m)	S	I 1:	P_t (KW)			IEC Motor type	Check Thermal Power Pt >= P1	Dimension Page Number
27.5	474	2.87	50.9	7.5	EP301L3	--	90L-4	OK	PAGE 90
28.5	472	3.40	49.1	9.0	EP303L2	--	90L-4	OK	PAGE 100
33.7	399	1.59	41.5	7.5	EP300L2	--	90L-4	OK	PAGE 80
33.7	399	2.95	41.5	7.5	EP301L2	--	90L-4	OK	PAGE 90
34.6	377	1.93	40.5	12.0	--	EP300R3	90L-4	OK	PAGE 80
36.1	361	2.05	38.8	7.5	EP300L3	--	90L-4	OK	PAGE 80
43.8	308	2.33	32.0	7.5	EP300L2	--	90L-4	OK	PAGE 80
45.4	287	2.46	30.8	12.0	--	EP300R3	90L-4	OK	PAGE 80
54.6	247	2.84	25.6	7.5	EP300L2	--	90L-4	OK	PAGE 80
59.6	219	2.93	23.5	12.0	--	EP300R3	90L-4	OK	PAGE 80
94.9	142	2.84	14.8	12.0	--	EP300R2	90L-4	OK	PAGE 80

EP300 series gear motor

P1=2.2KW n1=1400 min⁻¹

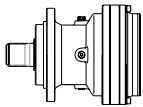
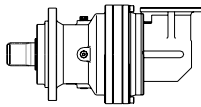
n₂ (min ⁻¹)	M₂ (N.m)	S	I 1:	P_t (KW)			IEC Motor type	Check Thermal Power Pt >= P1	Dimension Page Number
0.7	27122	2.89	2054	18.0	EP315L4	--	100L1-4	OK	PAGE 180
0.72	25572	0.91	1937	11.0	EP310L4	--	100L1-4	OK	PAGE 150
0.73	25166	1.28	1906	11.0	EP311L4	--	100L1-4	OK	PAGE 160
0.75	24545	1.86	1859	11.0	EP313L4	--	100L1-4	OK	PAGE 170
0.87	21205	1.78	1606	11.0	EP311L4	--	100L1-4	OK	PAGE 160
0.88	20896	1.03	1582	11.0	EP310L4	--	100L1-4	OK	PAGE 150
0.89	20700	2.36	1568	11.0	EP313L4	--	100L1-4	OK	PAGE 170
0.92	20023	0.87	1516	7.5	EP309L4	--	100L1-4	OK	PAGE 140
1.0	18753	1.36	1420	11.0	EP310L4	--	100L1-4	OK	PAGE 150
1.0	17867	2.07	1353	11.0	EP311L4	--	100L1-4	OK	PAGE 160
1.1	17442	2.77	1321	11.0	EP313L4	--	100L1-4	OK	PAGE 170
1.1	16743	1.24	1268	11.0	EP310L4	--	100L1-4	OK	PAGE 150
1.2	16044	1.03	1215	7.5	EP309L4	--	100L1-4	OK	PAGE 140
1.2	15324	1.57	1160	11.0	EP310L4	--	100L1-4	OK	PAGE 150
1.3	14600	2.48	1106	11.0	EP311L4	--	100L1-4	OK	PAGE 160
1.3	14398	1.12	1090	7.5	EP309L4	--	100L1-4	OK	PAGE 140
1.3	14252	3.31	1079	11.0	EP313L4	--	100L1-4	OK	PAGE 170
1.5	12279	1.82	930	11.0	EP310L4	--	100L1-4	OK	PAGE 150
1.5	12067	0.91	914	7.5	EP307L4	--	100L1-4	OK	PAGE 130
1.5	12067	1.36	914	7.5	EP309L4	--	100L1-4	OK	PAGE 140
1.6	11699	3.02	886	11.0	EP311L4	--	100L1-4	OK	PAGE 160
1.7	11154	1.78	845	14.0	--	EP310R4	100L1-4	OK	PAGE 150
1.7	11019	1.98	834	11.0	EP310L4	--	100L1-4	OK	PAGE 150
1.8	10499	3.31	795	11.0	EP311L4	--	100L1-4	OK	PAGE 160
1.8	10136	1.07	768	7.5	EP307L4	--	100L1-4	OK	PAGE 130
1.8	10136	1.86	768	7.5	EP309L4	--	100L1-4	OK	PAGE 140
1.9	9654	0.99	731	6.0	EP306L4	--	100L1-4	OK	PAGE 120
2.0	9411	2.31	713	11.0	EP310L4	--	100L1-4	OK	PAGE 150
2.0	9101	2.07	689	14.0	--	EP310R4	100L1-4	OK	PAGE 150
2.2	8280	1.03	627	14.0	--	EP307R4	100L1-4	OK	PAGE 130
2.2	8280	1.65	627	14.0	--	EP309R4	100L1-4	OK	PAGE 140

EP300 series gear motor

P1=2.2KW n1=1400 min⁻¹

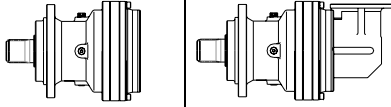
n ₂ (min ⁻¹)	M ₂ (N.m)	S	I 1:	P _t (KW)			IEC Motor type	Check Thermal Power Pt >= P1	Dimension Page Number
2.3	7981	2.69	604	11.0	EP310L4	--	100L1-4	OK	PAGE 150
2.4	7809	1.36	591	7.5	EP307L4	--	100L1-4	OK	PAGE 130
2.4	7809	2.27	591	7.5	EP309L4	--	100L1-4	OK	PAGE 140
2.4	7735	1.20	586	6.0	EP306L4	--	100L1-4	OK	PAGE 120
2.5	7437	2.48	563	14.0	--	EP310R4	100L1-4	OK	PAGE 150
2.6	6977	1.36	528	14.0	--	EP307R4	100L1-4	OK	PAGE 130
2.6	6977	1.86	528	14.0	--	EP309R4	100L1-4	OK	PAGE 140
2.8	6704	3.51	508	11.0	EP310L4	--	100L1-4	OK	PAGE 150
2.8	6674	3.18	505	14.0	--	EP310R4	100L1-4	OK	PAGE 150
2.9	6283	0.99	476	12.0	--	EP306R4	100L1-4	OK	PAGE 120
3.0	6257	1.65	474	7.5	EP307L4	--	100L1-4	OK	PAGE 130
3.0	6257	2.69	474	7.5	EP309L4	--	100L1-4	OK	PAGE 140
3.1	5959	1.57	451	6.0	EP306L4	--	100L1-4	OK	PAGE 120
3.2	5701	1.65	432	14.0	--	EP307R4	100L1-4	OK	PAGE 130
3.2	5701	2.89	432	14.0	--	EP309R4	100L1-4	OK	PAGE 140
3.4	5454	0.95	413	6.0	EP305L4	--	100L1-4	OK	PAGE 110
3.7	5034	1.20	381	12.0	--	EP306R4	100L1-4	OK	PAGE 120
3.8	4820	2.07	365	7.5	EP307L4	--	100L1-4	OK	PAGE 130
3.8	4820	3.31	365	7.5	EP309L4	--	100L1-4	OK	PAGE 140
3.8	4813	1.07	364	6.0	EP305L4	--	100L1-4	OK	PAGE 110
3.9	4723	1.07	358	12.0	--	EP305R4	100L1-4	OK	PAGE 110
4.0	4753	1.12	348	7.5	EP306L3	--	100L1-4	OK	PAGE 120
4.0	4753	1.12	348	7.5	EP306L3	--	100L1-4	OK	PAGE 120
4.0	4568	2.07	346	14.0	--	EP307R4	100L1-4	OK	PAGE 130
4.0	4568	3.31	346	14.0	--	EP309R4	100L1-4	OK	PAGE 140
4.1	4538	2.02	344	6.0	EP306L4	--	100L1-4	OK	PAGE 120
4.1	4518	1.32	342	12.0	--	EP306R4	100L1-4	OK	PAGE 120
4.4	4202	1.20	318	6.0	EP305L4	--	100L1-4	OK	PAGE 110
4.5	4100	2.27	310	14.0	--	EP307R4	100L1-4	OK	PAGE 130
4.6	4177	2.00	306	11.0	EP307L3	--	100L1-4	OK	PAGE 130
4.6	4177	2.80	306	11.0	EP309L3	--	100L1-4	OK	PAGE 140
4.8	3858	1.98	292	12.0	--	EP306R4	100L1-4	OK	PAGE 120
4.9	3784	1.36	287	12.0	--	EP305R4	100L1-4	OK	PAGE 110
4.9	3878	1.68	284	7.5	EP306L3	--	100L1-4	OK	PAGE 120
4.9	3878	1.68	284	7.5	EP306L3	--	100L1-4	OK	PAGE 120
5.0	3671	2.48	278	7.5	EP307L4	--	100L1-4	OK	PAGE 130
5.0	3665	1.36	278	6.0	EP305L4	--	100L1-4	OK	PAGE 110
5.3	3479	2.56	263	6.0	EP306L4	--	100L1-4	OK	PAGE 120
5.4	3436	2.48	260	14.0	--	EP307R4	100L1-4	OK	PAGE 130
5.4	3539	0.96	259	7.5	EP305L3	--	100L1-4	OK	PAGE 110
5.4	3519	2.80	258	11.0	EP307L3	--	100L1-4	OK	PAGE 130
6.0	3169	2.04	232	7.5	EP306L3	--	100L1-4	OK	PAGE 120
6.0	3169	2.04	232	7.5	EP306L3	--	100L1-4	OK	PAGE 120
6.3	2915	1.65	221	12.0	--	EP305R4	100L1-4	OK	PAGE 110
6.4	2886	2.89	219	14.0	--	EP307R4	100L1-4	OK	PAGE 130
6.6	2876	3.20	211	11.0	EP307L3	--	100L1-4	OK	PAGE 130
6.7	2749	3.10	208	12.0	--	EP306R4	100L1-4	OK	PAGE 120
6.7	2836	1.52	208	7.5	EP305L3	--	100L1-4	OK	PAGE 110
6.9	2680	3.31	203	6.0	EP306L4	--	100L1-4	OK	PAGE 120
8.0	2382	1.04	174	7.5	EP303L3	--	100L1-4	OK	PAGE 100
8.0	2382	2.00	174	7.5	EP305L3	--	100L1-4	OK	PAGE 110

EP300 series gear motor

P1=2.2KW n1=1400 min⁻¹

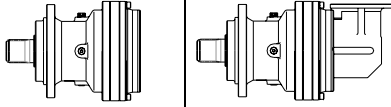
n ₂ (min ⁻¹)	M ₂ (N.m)	S	I 1:	P _t (KW)			IEC Motor type	Check Thermal Power Pt >= P1	Dimension Page Number
					EP300L3	EP301L3			
8.3	2220	1.07	168	12.0	--	EP303R4	100L1-4	OK	PAGE 100
8.3	2220	1.86	168	12.0	--	EP305R4	100L1-4	OK	PAGE 110
8.4	2279	2.76	167	7.5	EP306L3	--	100L1-4	OK	PAGE 120
8.4	2279	2.76	167	7.5	EP306L3	--	100L1-4	OK	PAGE 120
9.5	1938	1.20	147	12.0	--	EP303R4	100L1-4	OK	PAGE 100
9.5	1938	2.07	147	12.0	--	EP305R4	100L1-4	OK	PAGE 110
10.0	1909	1.28	140	7.5	EP303L3	--	100L1-4	OK	PAGE 100
10.0	1909	2.48	140	7.5	EP305L3	--	100L1-4	OK	PAGE 110
10.3	1789	0.91	135	10.0	--	EP301R4	100L1-4	OK	PAGE 90
10.8	1710	1.32	130	12.0	--	EP303R4	100L1-4	OK	PAGE 100
10.8	1710	2.27	130	12.0	--	EP305R4	100L1-4	OK	PAGE 110
12.3	1556	0.96	114	7.5	EP301L3	--	100L1-4	OK	PAGE 90
12.4	1493	1.49	113	12.0	--	EP303R4	100L1-4	OK	PAGE 100
12.4	1493	2.52	113	12.0	--	EP305R4	100L1-4	OK	PAGE 110
12.9	1479	1.00	108	7.5	EP301L3	--	100L1-4	OK	PAGE 90
13.0	1471	1.60	108	7.5	EP303L3	--	100L1-4	OK	PAGE 100
13.0	1471	2.80	108	7.5	EP305L3	--	100L1-4	OK	PAGE 110
13.4	1378	1.12	104	10.0	--	EP301R4	100L1-4	OK	PAGE 90
13.9	1374	1.20	101	14.0	--	EP303R3	100L1-4	OK	PAGE 100
13.9	1374	2.12	101	14.0	--	EP305R3	100L1-4	OK	PAGE 110
14.2	1302	1.65	98.6	12.0	--	EP303R4	100L1-4	OK	PAGE 100
14.2	1302	2.89	98.6	12.0	--	EP305R4	100L1-4	OK	PAGE 110
15.9	1199	1.20	87.8	7.5	EP301L3	--	100L1-4	OK	PAGE 90
16.4	1163	1.08	85.2	12.0	--	EP301R3	100L1-4	OK	PAGE 90
17.0	1123	1.48	82.2	14.0	--	EP303R3	100L1-4	OK	PAGE 100
17.0	1123	2.80	82.2	14.0	--	EP305R3	100L1-4	OK	PAGE 110
17.1	1120	2.00	82.0	7.5	EP303L3	--	100L1-4	OK	PAGE 100
17.6	1050	1.45	79.5	10.0	--	EP301R4	100L1-4	OK	PAGE 90
19.0	1008	1.68	73.8	14.0	--	EP303R3	100L1-4	OK	PAGE 100
19.6	978	2.20	71.6	7.5	EP303L3	--	100L1-4	OK	PAGE 100
21.2	902	0.88	66.1	7.5	EP300L3	--	100L1-4	OK	PAGE 80
21.2	902	1.52	66.1	7.5	EP301L3	--	100L1-4	OK	PAGE 90
21.2	900	1.80	65.9	14.0	--	EP303R3	100L1-4	OK	PAGE 100
21.3	896	0.88	65.6	12.0	--	EP300R3	100L1-4	OK	PAGE 80
21.3	896	1.64	65.6	12.0	--	EP301R3	100L1-4	OK	PAGE 90
22.2	863	2.48	63.2	7.5	EP303L3	--	100L1-4	OK	PAGE 100
22.8	840	2.24	61.5	14.0	--	EP303R3	100L1-4	OK	PAGE 100
23.7	807	1.92	59.1	14.0	--	EP303R3	100L1-4	OK	PAGE 100
25.4	753	2.80	55.2	7.5	EP303L3	--	100L1-4	OK	PAGE 100
26.6	718	1.08	52.6	12.0	--	EP300R3	100L1-4	OK	PAGE 80
26.6	718	2.00	52.6	12.0	--	EP301R3	100L1-4	OK	PAGE 90
27.0	709	2.72	51.9	14.0	--	EP303R3	100L1-4	OK	PAGE 100
27.0	731	1.39	51.8	7.5	EP301L2	--	100L1-4	OK	PAGE 90
27.5	695	1.12	50.9	7.5	EP300L3	--	100L1-4	OK	PAGE 80
27.5	695	1.96	50.9	7.5	EP301L3	--	100L1-4	OK	PAGE 90
28.2	678	3.48	49.7	14.0	--	EP303R3	100L1-4	OK	PAGE 100
28.5	692	2.32	49.1	9.0	EP303L2	--	100L1-4	OK	PAGE 100
29.1	657	3.20	48.1	7.5	EP303L3	--	100L1-4	OK	PAGE 100
33.7	586	1.08	41.5	7.5	EP300L2	--	100L1-4	OK	PAGE 80
33.7	586	2.01	41.5	7.5	EP301L2	--	100L1-4	OK	PAGE 90
34.6	553	1.32	40.5	12.0	--	EP300R3	100L1-4	OK	PAGE 80

EP300 series gear motor

P1=2.2KW n1=1400 min⁻¹

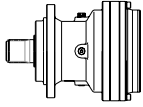
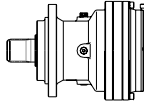
n ₂ (min ⁻¹)	M ₂ (N.m)	S	I 1:	P _t (KW)			IEC Motor type	Check Thermal	Dimension
								Power Pt >= P1	Page Number
34.6	553	2.52	40.5	12.0	--	EP301R3	100L1-4	OK	PAGE 90
34.9	566	3.09	40.1	9.0	EP303L2	--	100L1-4	OK	PAGE 100
36.1	529	1.40	38.8	7.5	EP300L3	--	100L1-4	OK	PAGE 80
36.1	529	2.40	38.8	7.5	EP301L3	--	100L1-4	OK	PAGE 90
43.8	451	1.59	32.0	7.5	EP300L2	--	100L1-4	OK	PAGE 80
43.8	451	2.90	32.0	7.5	EP301L2	--	100L1-4	OK	PAGE 90
45.4	421	1.68	30.8	12.0	--	EP300R3	100L1-4	OK	PAGE 80
45.4	421	3.08	30.8	12.0	--	EP301R3	100L1-4	OK	PAGE 90
54.6	362	1.93	25.6	7.5	EP300L2	--	100L1-4	OK	PAGE 80
54.6	362	3.17	25.6	7.5	EP301L2	--	100L1-4	OK	PAGE 90
59.6	321	2.00	23.5	12.0	--	EP300R3	100L1-4	OK	PAGE 80
59.6	321	3.20	23.5	12.0	--	EP301R3	100L1-4	OK	PAGE 90
70.9	279	2.40	19.8	7.5	EP300L2	--	100L1-4	OK	PAGE 80
93.1	212	2.90	15.0	7.5	EP300L2	--	100L1-4	OK	PAGE 80
94.9	208	1.93	14.8	12.0	--	EP300R2	100L1-4	OK	PAGE 80
118	167	2.90	11.8	12.0	--	EP300R2	100L1-4	OK	PAGE 80

EP300 series gear motor

P1=3.0KW n1=1400 min⁻¹

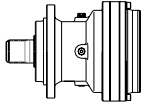
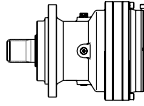
n ₂ (min ⁻¹)	M ₂ (N.m)	S	I 1:	P _t (KW)			IEC Motor type	Check Thermal	Dimension
								Power Pt >= P1	Page Number
0.7	36984	2.12	2054	18.0	EP315L4	--	100L2-4	OK	PAGE 180
0.73	34318	0.94	1906	11.0	EP311L4	--	100L2-4	OK	PAGE 160
0.75	33470	1.36	1859	11.0	EP313L4	--	100L2-4	OK	PAGE 170
0.8	31162	2.73	1731	18.0	EP315L4	--	100L2-4	OK	PAGE 180
0.87	28916	1.30	1606	11.0	EP311L4	--	100L2-4	OK	PAGE 160
0.89	28227	1.73	1568	11.0	EP313L4	--	100L2-4	OK	PAGE 170
1.0	25572	1.00	1420	11.0	EP310L4	--	100L2-4	OK	PAGE 150
1.0	25427	3.18	1412	18.0	EP315L4	--	100L2-4	OK	PAGE 180
1.0	24364	1.52	1353	11.0	EP311L4	--	100L2-4	OK	PAGE 160
1.1	23784	2.03	1321	11.0	EP313L4	--	100L2-4	OK	PAGE 170
1.1	22832	0.91	1268	11.0	EP310L4	--	100L2-4	OK	PAGE 150
1.1	22129	3.18	1229	18.0	EP315L4	--	100L2-4	OK	PAGE 180
1.2	20896	1.15	1160	11.0	EP310L4	--	100L2-4	OK	PAGE 150
1.3	19909	1.82	1106	11.0	EP311L4	--	100L2-4	OK	PAGE 160
1.3	19435	2.42	1079	11.0	EP313L4	--	100L2-4	OK	PAGE 170
1.5	16743	1.33	930	11.0	EP310L4	--	100L2-4	OK	PAGE 150
1.5	16455	1.00	914	7.5	EP309L4	--	100L2-4	OK	PAGE 140
1.6	15953	2.21	886	11.0	EP311L4	--	100L2-4	OK	PAGE 160
1.6	15573	2.73	865	11.0	EP313L4	--	100L2-4	OK	PAGE 170
1.7	15210	1.30	845	14.0	--	EP310R4	100L2-4	OK	PAGE 150
1.7	15026	1.45	834	11.0	EP310L4	--	100L2-4	OK	PAGE 150
1.8	14317	2.42	795	11.0	EP311L4	--	100L2-4	OK	PAGE 160
1.8	13976	3.03	776	11.0	EP313L4	--	100L2-4	OK	PAGE 170
1.8	13822	1.36	768	7.5	EP309L4	--	100L2-4	OK	PAGE 140
2.0	12833	1.70	713	11.0	EP310L4	--	100L2-4	OK	PAGE 150
2.0	12411	1.52	689	14.0	--	EP310R4	100L2-4	OK	PAGE 150

EP300 series gear motor

P1=3.0KW n1=1400 min⁻¹

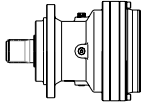
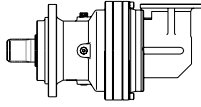
n ₂ (min ⁻¹)	M ₂ (N.m)	S	I 1:	P _t (KW)			IEC Motor type	Check Thermal	Dimension
								Power Pt >= P1	Page Number
2.1	11999	2.88	666	11.0	EP311L4	--	100L2-4	OK	PAGE 160
2.1	11912	3.33	662	22.0	--	EP313R4	100L2-4	OK	PAGE 170
2.2	11291	1.21	627	14.0	--	EP309R4	100L2-4	OK	PAGE 140
2.3	10883	1.97	604	11.0	EP310L4	--	100L2-4	OK	PAGE 150
2.4	10648	1.00	591	7.5	EP307L4	--	100L2-4	OK	PAGE 130
2.4	10648	1.67	591	7.5	EP309L4	--	100L2-4	OK	PAGE 140
2.4	10548	0.88	586	6.0	EP306L4	--	100L2-4	OK	PAGE 120
2.5	10141	1.82	563	14.0	--	EP310R4	100L2-4	OK	PAGE 150
2.5	10079	3.39	560	11.0	EP311L4	--	100L2-4	OK	PAGE 160
2.6	9771	2.88	543	22.0	--	EP311R4	100L2-4	OK	PAGE 160
2.6	9514	1.00	528	14.0	--	EP307R4	100L2-4	OK	PAGE 130
2.6	9514	1.36	528	14.0	--	EP309R4	100L2-4	OK	PAGE 140
2.8	9142	2.58	508	11.0	EP310L4	--	100L2-4	OK	PAGE 150
2.8	9101	2.33	505	14.0	--	EP310R4	100L2-4	OK	PAGE 150
3.0	8532	1.21	474	7.5	EP307L4	--	100L2-4	OK	PAGE 130
3.0	8532	1.97	474	7.5	EP309L4	--	100L2-4	OK	PAGE 140
3.1	8126	1.15	451	6.0	EP306L4	--	100L2-4	OK	PAGE 120
3.2	7774	1.21	432	14.0	--	EP307R4	100L2-4	OK	PAGE 130
3.2	7774	2.12	432	14.0	--	EP309R4	100L2-4	OK	PAGE 140
3.3	7679	2.88	426	11.0	EP310L4	--	100L2-4	OK	PAGE 150
3.4	7437	2.82	413	14.0	--	EP310R4	100L2-4	OK	PAGE 150
3.8	6674	3.09	371	14.0	--	EP310R4	100L2-4	OK	PAGE 150
3.8	6573	1.52	365	7.5	EP307L4	--	100L2-4	OK	PAGE 130
3.8	6573	2.42	365	7.5	EP309L4	--	100L2-4	OK	PAGE 140
4.0	6229	1.52	346	14.0	--	EP307R4	100L2-4	OK	PAGE 130
4.0	6229	2.42	346	14.0	--	EP309R4	100L2-4	OK	PAGE 140
4.1	6188	1.48	344	6.0	EP306L4	--	100L2-4	OK	PAGE 120
4.1	6161	0.97	342	12.0	--	EP306R4	100L2-4	OK	PAGE 120
4.2	6138	2.78	330	18.0	EP310L3	--	100L2-4	OK	PAGE 150
4.3	5916	3.64	329	11.0	EP310L4	--	100L2-4	OK	PAGE 150
4.4	5730	0.88	318	6.0	EP305L4	--	100L2-4	OK	PAGE 110
4.5	5590	1.67	310	14.0	--	EP307R4	100L2-4	OK	PAGE 130
4.5	5590	2.73	310	14.0	--	EP309R4	100L2-4	OK	PAGE 140
4.6	5696	1.47	306	11.0	EP307L3	--	100L2-4	OK	PAGE 130
4.8	5261	1.45	292	12.0	--	EP306R4	100L2-4	OK	PAGE 120
4.9	5160	1.00	287	12.0	--	EP305R4	100L2-4	OK	PAGE 110
4.9	5289	1.23	284	7.5	EP306L3	--	100L2-4	OK	PAGE 120
5.0	5006	1.82	278	7.5	EP307L4	--	100L2-4	OK	PAGE 130
5.0	5006	3.03	278	7.5	EP309L4	--	100L2-4	OK	PAGE 140
5.0	4998	1.00	278	6.0	EP305L4	--	100L2-4	OK	PAGE 110
5.2	5008	3.37	269	18.0	EP310L3	--	100L2-4	OK	PAGE 150
5.3	4744	1.88	263	6.0	EP306L4	--	100L2-4	OK	PAGE 120
5.4	4685	1.82	260	14.0	--	EP307R4	100L2-4	OK	PAGE 130
5.4	4685	3.18	260	14.0	--	EP309R4	100L2-4	OK	PAGE 140
5.4	4799	2.05	258	11.0	EP307L3	--	100L2-4	OK	PAGE 130
5.4	4799	2.34	258	11.0	EP309L3	--	100L2-4	OK	PAGE 140
6.0	4322	1.49	232	7.5	EP306L3	--	100L2-4	OK	PAGE 120
6.3	3975	1.21	221	12.0	--	EP305R4	100L2-4	OK	PAGE 110
6.4	3936	2.12	219	14.0	--	EP307R4	100L2-4	OK	PAGE 130
6.6	3921	2.34	211	11.0	EP307L3	--	100L2-4	OK	PAGE 130
6.7	3748	2.27	208	12.0	--	EP306R4	100L2-4	OK	PAGE 120

EP300 series gear motor

P1=3.0KW n1=1400 min⁻¹

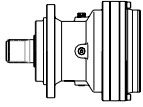
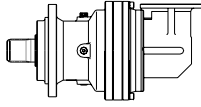
n₂ (min ⁻¹)	M₂ (N.m)	S	I 1:	P_t (KW)			IEC Motor type	Check Thermal Power Pt >= P1	Dimension Page Number
6.7	3867	1.11	208	7.5	EP305L3	--	100L2-4	OK	PAGE 110
6.9	3655	2.42	203	6.0	EP306L4	--	100L2-4	OK	PAGE 120
8.0	3249	1.47	174	7.5	EP305L3	--	100L2-4	OK	PAGE 110
8.3	3142	2.93	169	11.0	EP307L3	--	100L2-4	OK	PAGE 130
8.3	3032	2.73	168	14.0	--	EP307R4	100L2-4	OK	PAGE 130
8.3	3027	1.36	168	12.0	--	EP305R4	100L2-4	OK	PAGE 110
8.4	3108	2.02	167	7.5	EP306L3	--	100L2-4	OK	PAGE 120
8.7	2887	2.88	160	12.0	--	EP306R4	100L2-4	OK	PAGE 120
9.2	2820	3.46	151	11.0	EP307L3	--	100L2-4	OK	PAGE 130
9.5	2643	0.88	147	12.0	--	EP303R4	100L2-4	OK	PAGE 100
9.5	2643	1.52	147	12.0	--	EP305R4	100L2-4	OK	PAGE 110
9.8	2654	2.64	143	7.5	EP306L3	--	100L2-4	OK	PAGE 120
10.0	2603	0.94	140	7.5	EP303L3	--	100L2-4	OK	PAGE 100
10.0	2603	1.82	140	7.5	EP305L3	--	100L2-4	OK	PAGE 110
10.8	2332	0.97	130	12.0	--	EP303R4	100L2-4	OK	PAGE 100
10.8	2332	1.67	130	12.0	--	EP305R4	100L2-4	OK	PAGE 110
10.9	2309	3.33	128	14.0	--	EP307R4	100L2-4	OK	PAGE 130
11.5	2199	3.42	122	12.0	--	EP306R4	100L2-4	OK	PAGE 120
12.4	2036	1.09	113	12.0	--	EP303R4	100L2-4	OK	PAGE 100
12.4	2036	1.85	113	12.0	--	EP305R4	100L2-4	OK	PAGE 110
12.9	2027	3.52	109	20.0	--	EP307R3	100L2-4	OK	PAGE 130
13.0	2005	1.17	108	7.5	EP303L3	--	100L2-4	OK	PAGE 100
13.0	2005	2.05	108	7.5	EP305L3	--	100L2-4	OK	PAGE 110
13.8	1891	3.22	102	7.5	EP306L3	--	100L2-4	OK	PAGE 120
13.9	1874	0.88	101	14.0	--	EP303R3	100L2-4	OK	PAGE 100
13.9	1874	1.55	101	14.0	--	EP305R3	100L2-4	OK	PAGE 110
14.1	1846	2.64	99.1	14.0	--	EP306R3	100L2-4	OK	PAGE 120
14.2	1776	1.21	98.6	12.0	--	EP303R4	100L2-4	OK	PAGE 100
14.2	1776	2.12	98.6	12.0	--	EP305R4	100L2-4	OK	PAGE 110
15.9	1635	0.88	87.8	7.5	EP301L3	--	100L2-4	OK	PAGE 90
17.0	1531	1.08	82.2	14.0	--	EP303R3	100L2-4	OK	PAGE 100
17.0	1531	2.05	82.2	14.0	--	EP305R3	100L2-4	OK	PAGE 110
17.1	1527	1.47	82.0	7.5	EP303L3	--	100L2-4	OK	PAGE 100
17.1	1527	2.64	82.0	7.5	EP305L3	--	100L2-4	OK	PAGE 110
17.6	1431	1.06	79.5	10.0	--	EP301R4	100L2-4	OK	PAGE 90
19.0	1374	1.23	73.8	14.0	--	EP303R3	100L2-4	OK	PAGE 100
19.6	1333	1.61	71.6	7.5	EP303L3	--	100L2-4	OK	PAGE 100
19.6	1333	2.64	71.6	7.5	EP305L3	--	100L2-4	OK	PAGE 110
21.2	1231	1.11	66.1	7.5	EP301L3	--	100L2-4	OK	PAGE 90
21.2	1227	1.32	65.9	14.0	--	EP303R3	100L2-4	OK	PAGE 100
21.2	1227	2.64	65.9	14.0	--	EP305R3	100L2-4	OK	PAGE 110
21.3	1222	1.20	65.6	12.0	--	EP301R3	100L2-4	OK	PAGE 90
22.2	1176	1.82	63.2	7.5	EP303L3	--	100L2-4	OK	PAGE 100
22.2	1176	2.64	63.2	7.5	EP305L3	--	100L2-4	OK	PAGE 110
22.8	1145	1.64	61.5	14.0	--	EP303R3	100L2-4	OK	PAGE 100
22.8	1145	2.93	61.5	14.0	--	EP305R3	100L2-4	OK	PAGE 110
23.7	1101	1.41	59.1	14.0	--	EP303R3	100L2-4	OK	PAGE 100
23.7	1101	2.93	59.1	14.0	--	EP305R3	100L2-4	OK	PAGE 110
25.4	1027	2.05	55.2	7.5	EP303L3	--	100L2-4	OK	PAGE 100
25.4	1027	2.93	55.2	7.5	EP305L3	--	100L2-4	OK	PAGE 110
26.6	979	1.47	52.6	12.0	--	EP301R3	100L2-4	OK	PAGE 90

EP300 series gear motor

P1=3.0KW n1=1400 min⁻¹

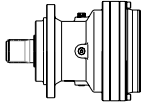
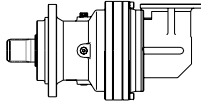
n₂ (min ⁻¹)	M₂ (N.m)	S	I 1:	P_t (KW)			IEC Motor type	Check Thermal Power Pt >= P1	Dimension Page Number
27.0	966	1.99	51.9	14.0	--	EP303R3	100L2-4	OK	PAGE 100
27.0	997	1.02	51.8	7.5	EP301L2	--	100L2-4	OK	PAGE 90
27.1	962	2.70	51.7	14.0	--	EP303R3	100L2-4	OK	PAGE 100
27.5	948	1.44	50.9	7.5	EP301L3	--	100L2-4	OK	PAGE 90
28.2	925	2.55	49.7	14.0	--	EP303R3	100L2-4	OK	PAGE 100
28.5	944	1.70	49.1	9.0	EP303L2	--	100L2-4	OK	PAGE 100
28.5	944	2.84	49.1	9.0	EP305L2	--	100L2-4	OK	PAGE 110
29.1	896	2.34	48.1	7.5	EP303L3	--	100L2-4	OK	PAGE 100
33.7	799	1.48	41.5	7.5	EP301L2	--	100L2-4	OK	PAGE 90
34.6	754	0.97	40.5	12.0	--	EP300R3	100L2-4	OK	PAGE 80
34.6	754	1.85	40.5	12.0	--	EP301R3	100L2-4	OK	PAGE 90
34.9	772	2.27	40.1	9.0	EP303L2	--	100L2-4	OK	PAGE 100
36.1	722	1.03	38.8	7.5	EP300L3	--	100L2-4	OK	PAGE 80
36.1	722	1.76	38.8	7.5	EP301L3	--	100L2-4	OK	PAGE 90
43.6	618	2.84	32.1	9.0	EP303L2	--	100L2-4	OK	PAGE 100
43.8	616	1.16	32.0	7.5	EP300L2	--	100L2-4	OK	PAGE 80
43.8	616	2.13	32.0	7.5	EP301L2	--	100L2-4	OK	PAGE 90
45.4	574	1.23	30.8	12.0	--	EP300R3	100L2-4	OK	PAGE 80
45.4	574	2.26	30.8	12.0	--	EP301R3	100L2-4	OK	PAGE 90
46.7	577	3.26	30.0	9.0	EP303L2	--	100L2-4	OK	PAGE 100
48.5	555	3.40	28.8	9.0	EP303L2	--	100L2-4	OK	PAGE 100
54.6	493	1.42	25.6	7.5	EP300L2	--	100L2-4	OK	PAGE 80
54.6	493	2.33	25.6	7.5	EP301L2	--	100L2-4	OK	PAGE 90
59.6	437	1.47	23.5	12.0	--	EP300R3	100L2-4	OK	PAGE 80
59.6	437	2.34	23.5	12.0	--	EP301R3	100L2-4	OK	PAGE 90
70.9	380	1.76	19.8	7.5	EP300L2	--	100L2-4	OK	PAGE 80
70.9	380	2.84	19.8	7.5	EP301L2	--	100L2-4	OK	PAGE 90
93.1	289	2.13	15.0	7.5	EP300L2	--	100L2-4	OK	PAGE 80
93.1	289	3.40	15.0	7.5	EP301L2	--	100L2-4	OK	PAGE 90
94.9	284	1.42	14.8	12.0	--	EP300R2	100L2-4	OK	PAGE 80
94.9	284	3.12	14.8	12.0	--	EP301R2	100L2-4	OK	PAGE 90
118	227	2.13	11.8	12.0	--	EP300R2	100L2-4	OK	PAGE 80
122	220	2.55	11.5	7.5	EP300L2	--	100L2-4	OK	PAGE 80
194	143	3.02	7.2	7.5	EP300L1	--	100L2-4	OK	PAGE 80
194	143	3.02	7.2	7.5	EP300L1	--	100L2-4	OK	PAGE 80

EP300 series gear motor

P1=4.0KW n1=1400 min⁻¹

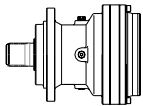
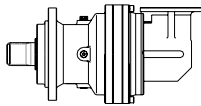
n₂ (min ⁻¹)	M₂ (N.m)	S	I 1:	P_t (KW)			IEC Motor type	Check Thermal Power Pt >= P1	Dimension Page Number
0.7	49312	1.59	2054	18.0	EP315L4	--	112M-4	OK	PAGE 180
0.75	44627	1.02	1859	11.0	EP313L4	--	112M-4	OK	PAGE 170
0.8	41550	2.05	1731	18.0	EP315L4	--	112M-4	OK	PAGE 180
0.87	38554	0.98	1606	11.0	EP311L4	--	112M-4	OK	PAGE 160
0.89	37636	1.30	1568	11.0	EP313L4	--	112M-4	OK	PAGE 170
1.0	33902	2.39	1412	18.0	EP315L4	--	112M-4	OK	PAGE 180

EP300 series gear motor

P1=4.0KW n1=1400 min⁻¹

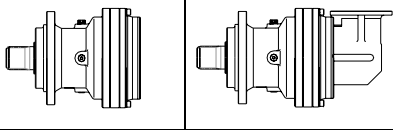
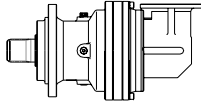
n ₂ (min ⁻¹)	M ₂ (N.m)	S	I 1:	P _t (KW)	 		IEC Motor type	Check Thermal Power Pt >= P1	Dimension Page Number
1.0	33364	3.52	1390	18.0	EP316L4	--	112M-4	OK	PAGE 190
1.0	32486	1.14	1353	11.0	EP311L4	--	112M-4	OK	PAGE 160
1.1	31712	1.52	1321	11.0	EP313L4	--	112M-4	OK	PAGE 170
1.1	29506	2.39	1229	18.0	EP315L4	--	112M-4	OK	PAGE 180
1.2	27861	0.86	1160	11.0	EP310L4	--	112M-4	OK	PAGE 150
1.3	26545	1.36	1106	11.0	EP311L4	--	112M-4	OK	PAGE 160
1.3	25913	1.82	1079	11.0	EP313L4	--	112M-4	OK	PAGE 170
1.4	24862	3.18	1036	18.0	EP315L4	--	112M-4	OK	PAGE 180
1.5	22325	1.00	930	11.0	EP310L4	--	112M-4	OK	PAGE 150
1.6	21270	1.66	886	11.0	EP311L4	--	112M-4	OK	PAGE 160
1.6	20764	2.05	865	11.0	EP313L4	--	112M-4	OK	PAGE 170
1.7	20280	0.98	845	14.0	--	EP310R4	112M-4	OK	PAGE 150
1.7	20035	1.09	834	11.0	EP310L4	--	112M-4	OK	PAGE 150
1.8	19089	1.82	795	11.0	EP311L4	--	112M-4	OK	PAGE 160
1.8	18634	2.27	776	11.0	EP313L4	--	112M-4	OK	PAGE 170
1.8	18430	1.02	768	7.5	EP309L4	--	112M-4	OK	PAGE 140
2.0	17110	1.27	713	11.0	EP310L4	--	112M-4	OK	PAGE 150
2.0	16547	1.14	689	14.0	--	EP310R4	112M-4	OK	PAGE 150
2.1	15998	2.16	666	11.0	EP311L4	--	112M-4	OK	PAGE 160
2.1	15883	2.50	662	22.0	--	EP313R4	112M-4	OK	PAGE 170
2.2	15617	2.84	650	11.0	EP313L4	--	112M-4	OK	PAGE 170
2.2	15055	0.91	627	14.0	--	EP309R4	112M-4	OK	PAGE 140
2.3	14511	1.48	604	11.0	EP310L4	--	112M-4	OK	PAGE 150
2.4	14198	1.25	591	7.5	EP309L4	--	112M-4	OK	PAGE 140
2.5	13522	1.36	563	14.0	--	EP310R4	112M-4	OK	PAGE 150
2.5	13439	2.55	560	11.0	EP311L4	--	112M-4	OK	PAGE 160
2.5	13395	3.41	558	22.0	--	EP313R4	112M-4	OK	PAGE 170
2.6	13119	3.41	546	11.0	EP313L4	--	112M-4	OK	PAGE 170
2.6	13028	2.16	543	22.0	--	EP311R4	112M-4	OK	PAGE 160
2.6	12685	1.02	528	14.0	--	EP309R4	112M-4	OK	PAGE 140
2.8	12189	1.93	508	11.0	EP310L4	--	112M-4	OK	PAGE 150
2.8	12135	1.75	505	14.0	--	EP310R4	112M-4	OK	PAGE 150
3.0	11377	0.91	474	7.5	EP307L4	--	112M-4	OK	PAGE 130
3.0	11377	1.48	474	7.5	EP309L4	--	112M-4	OK	PAGE 140
3.1	10977	3.02	457	22.0	--	EP311R4	112M-4	OK	PAGE 160
3.1	10835	0.86	451	6.0	EP306L4	--	112M-4	OK	PAGE 120
3.2	10472	3.18	436	11.0	EP311L4	--	112M-4	OK	PAGE 160
3.2	10365	0.91	432	14.0	--	EP307R4	112M-4	OK	PAGE 130
3.2	10365	1.59	432	14.0	--	EP309R4	112M-4	OK	PAGE 140
3.3	10239	2.16	426	11.0	EP310L4	--	112M-4	OK	PAGE 150
3.4	9916	2.11	413	14.0	--	EP310R4	112M-4	OK	PAGE 150
3.6	9249	3.52	385	22.0	--	EP311R4	112M-4	OK	PAGE 160
3.8	8899	2.32	371	14.0	--	EP310R4	112M-4	OK	PAGE 150
3.8	8764	1.14	365	7.5	EP307L4	--	112M-4	OK	PAGE 130
3.8	8764	1.82	365	7.5	EP309L4	--	112M-4	OK	PAGE 140
4.0	8306	1.14	346	14.0	--	EP307R4	112M-4	OK	PAGE 130
4.0	8306	1.82	346	14.0	--	EP309R4	112M-4	OK	PAGE 140
4.1	8251	1.11	344	6.0	EP306L4	--	112M-4	OK	PAGE 120
4.2	8184	2.09	330	18.0	EP310L3	--	112M-4	OK	PAGE 150
4.3	7888	2.73	329	11.0	EP310L4	--	112M-4	OK	PAGE 150
4.4	7600	2.61	317	14.0	--	EP310R4	112M-4	OK	PAGE 150

EP300 series gear motor

P1=4.0KW n1=1400 min⁻¹

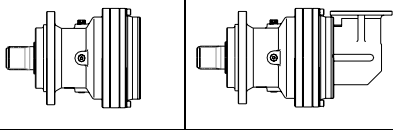
n ₂ (min ⁻¹)	M ₂ (N.m)	S	I 1:	P _t (KW)			IEC Motor type	Check Thermal Power Pt >= P1	Dimension Page Number
4.5	7454	1.25	310	14.0	--	EP307R4	112M-4	OK	PAGE 130
4.5	7454	2.05	310	14.0	--	EP309R4	112M-4	OK	PAGE 140
4.6	7594	1.10	306	11.0	EP307L3	--	112M-4	OK	PAGE 130
4.8	7015	1.09	292	12.0	--	EP306R4	112M-4	OK	PAGE 120
4.9	7052	0.92	284	7.5	EP306L3	--	112M-4	OK	PAGE 120
5.0	6674	1.36	278	7.5	EP307L4	--	112M-4	OK	PAGE 130
5.0	6674	2.27	278	7.5	EP309L4	--	112M-4	OK	PAGE 140
5.2	6678	2.53	269	18.0	EP310L3	--	112M-4	OK	PAGE 150
5.2	6445	2.95	268	14.0	--	EP310R4	112M-4	OK	PAGE 150
5.3	6572	3.52	265	18.0	EP311L3	--	112M-4	OK	PAGE 160
5.3	6326	1.41	263	6.0	EP306L4	--	112M-4	OK	PAGE 120
5.4	6247	1.36	260	14.0	--	EP307R4	112M-4	OK	PAGE 130
5.4	6247	2.39	260	14.0	--	EP309R4	112M-4	OK	PAGE 140
5.4	6399	1.54	258	11.0	EP307L3	--	112M-4	OK	PAGE 130
5.4	6399	1.76	258	11.0	EP309L3	--	112M-4	OK	PAGE 140
6.0	5762	1.12	232	7.5	EP306L3	--	112M-4	OK	PAGE 120
6.2	5414	3.41	226	14.0	--	EP310R4	112M-4	OK	PAGE 150
6.3	5300	0.91	221	12.0	--	EP305R4	112M-4	OK	PAGE 110
6.4	5457	3.08	220	18.0	EP310L3	--	112M-4	OK	PAGE 150
6.4	5247	1.59	219	14.0	--	EP307R4	112M-4	OK	PAGE 130
6.4	5247	2.73	219	14.0	--	EP309R4	112M-4	OK	PAGE 140
6.6	5229	1.76	211	11.0	EP307L3	--	112M-4	OK	PAGE 130
6.6	5229	2.86	211	11.0	EP309L3	--	112M-4	OK	PAGE 140
6.7	4998	1.70	208	12.0	--	EP306R4	112M-4	OK	PAGE 120
6.9	4873	1.82	203	6.0	EP306L4	--	112M-4	OK	PAGE 120
8.0	4331	1.10	174	7.5	EP305L3	--	112M-4	OK	PAGE 110
8.3	4190	2.20	169	11.0	EP307L3	--	112M-4	OK	PAGE 130
8.3	4190	3.52	169	11.0	EP309L3	--	112M-4	OK	PAGE 140
8.3	4042	2.05	168	14.0	--	EP307R4	112M-4	OK	PAGE 130
8.3	4042	3.41	168	14.0	--	EP309R4	112M-4	OK	PAGE 140
8.3	4036	1.02	168	12.0	--	EP305R4	112M-4	OK	PAGE 110
8.4	4144	1.52	167	7.5	EP306L3	--	112M-4	OK	PAGE 120
8.7	3850	2.16	160	12.0	--	EP306R4	112M-4	OK	PAGE 120
9.2	3760	2.59	151	11.0	EP307L3	--	112M-4	OK	PAGE 130
9.5	3524	1.14	147	12.0	--	EP305R4	112M-4	OK	PAGE 110
9.8	3539	1.98	143	7.5	EP306L3	--	112M-4	OK	PAGE 120
10.0	3471	1.36	140	7.5	EP305L3	--	112M-4	OK	PAGE 110
10.8	3110	1.25	130	12.0	--	EP305R4	112M-4	OK	PAGE 110
10.9	3078	2.50	128	14.0	--	EP307R4	112M-4	OK	PAGE 130
10.9	3078	3.52	128	14.0	--	EP309R4	112M-4	OK	PAGE 140
11.0	3151	3.08	127	11.0	EP307L3	--	112M-4	OK	PAGE 130
11.5	2932	2.57	122	12.0	--	EP306R4	112M-4	OK	PAGE 120
12.4	2715	1.39	113	12.0	--	EP305R4	112M-4	OK	PAGE 110
12.5	2688	2.73	112	14.0	--	EP307R4	112M-4	OK	PAGE 130
12.9	2703	2.64	109	20.0	--	EP307R3	112M-4	OK	PAGE 130
12.9	2703	3.52	109	20.0	--	EP309R3	112M-4	OK	PAGE 140
13.0	2674	0.88	108	7.5	EP303L3	--	112M-4	OK	PAGE 100
13.0	2674	1.54	108	7.5	EP305L3	--	112M-4	OK	PAGE 110
13.1	2647	3.52	107	11.0	EP307L3	--	112M-4	OK	PAGE 130
13.8	2521	2.42	102	7.5	EP306L3	--	112M-4	OK	PAGE 120
13.9	2499	1.16	101	14.0	--	EP305R3	112M-4	OK	PAGE 110

EP300 series gear motor

P1=4.0KW n1=1400 min⁻¹

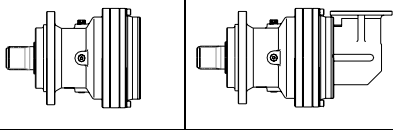
n ₂ (min ⁻¹)	M ₂ (N.m)	S	I 1:	P _t (KW)			IEC Motor type	Check Thermal Power Pt >= P1	Dimension Page Number
14.1	2461	1.98	99.1	14.0	--	EP306R3	112M-4	OK	PAGE 120
14.2	2368	0.91	98.6	12.0	--	EP303R4	112M-4	OK	PAGE 100
14.2	2368	1.59	98.6	12.0	--	EP305R4	112M-4	OK	PAGE 110
15.0	2248	3.18	93.6	12.0	--	EP306R4	112M-4	OK	PAGE 120
15.3	2277	3.30	91.7	20.0	--	EP307R3	112M-4	OK	PAGE 130
17.0	2042	1.54	82.2	14.0	--	EP305R3	112M-4	OK	PAGE 110
17.1	2036	1.10	82.0	7.5	EP303L3	--	112M-4	OK	PAGE 100
17.1	2036	1.98	82.0	7.5	EP305L3	--	112M-4	OK	PAGE 110
17.3	2008	2.86	80.9	14.0	--	EP306R3	112M-4	OK	PAGE 120
17.9	1942	2.86	78.2	7.5	EP306L3	--	112M-4	OK	PAGE 120
19.0	1832	0.92	73.8	14.0	--	EP303R3	112M-4	OK	PAGE 100
19.6	1778	1.21	71.6	7.5	EP303L3	--	112M-4	OK	PAGE 100
19.6	1778	1.98	71.6	7.5	EP305L3	--	112M-4	OK	PAGE 110
21.2	1641	3.30	66.1	14.0	--	EP306R3	112M-4	OK	PAGE 120
21.2	1636	0.99	65.9	14.0	--	EP303R3	112M-4	OK	PAGE 100
21.2	1636	1.98	65.9	14.0	--	EP305R3	112M-4	OK	PAGE 110
21.3	1629	0.90	65.6	12.0	--	EP301R3	112M-4	OK	PAGE 90
22.2	1569	1.36	63.2	7.5	EP303L3	--	112M-4	OK	PAGE 100
22.2	1569	1.98	63.2	7.5	EP305L3	--	112M-4	OK	PAGE 110
22.8	1527	1.23	61.5	14.0	--	EP303R3	112M-4	OK	PAGE 100
22.8	1527	2.20	61.5	14.0	--	EP305R3	112M-4	OK	PAGE 110
23.7	1468	1.05	59.1	14.0	--	EP303R3	112M-4	OK	PAGE 100
23.7	1468	2.20	59.1	14.0	--	EP305R3	112M-4	OK	PAGE 110
25.4	1369	1.54	55.2	7.5	EP303L3	--	112M-4	OK	PAGE 100
25.4	1369	2.20	55.2	7.5	EP305L3	--	112M-4	OK	PAGE 110
26.6	1305	1.10	52.6	12.0	--	EP301R3	112M-4	OK	PAGE 90
27.0	1288	1.49	51.9	14.0	--	EP303R3	112M-4	OK	PAGE 100
27.1	1283	2.02	51.7	14.0	--	EP303R3	112M-4	OK	PAGE 100
27.1	1283	2.64	51.7	14.0	--	EP305R3	112M-4	OK	PAGE 110
27.5	1264	1.08	50.9	7.5	EP301L3	--	112M-4	OK	PAGE 90
28.2	1233	1.91	49.7	14.0	--	EP303R3	112M-4	OK	PAGE 100
28.2	1233	2.64	49.7	14.0	--	EP305R3	112M-4	OK	PAGE 110
28.5	1259	1.28	49.1	9.0	EP303L2	--	112M-4	OK	PAGE 100
28.5	1259	2.13	49.1	9.0	EP305L2	--	112M-4	OK	PAGE 110
29.0	1240	3.40	48.3	13.0	EP306L2	--	112M-4	OK	PAGE 120
29.1	1195	1.76	48.1	7.5	EP303L3	--	112M-4	OK	PAGE 100
29.1	1195	2.64	48.1	7.5	EP305L3	--	112M-4	OK	PAGE 110
33.7	1065	1.11	41.5	7.5	EP301L2	--	112M-4	OK	PAGE 90
34.6	1005	1.38	40.5	12.0	--	EP301R3	112M-4	OK	PAGE 90
34.9	1029	1.70	40.1	9.0	EP303L2	--	112M-4	OK	PAGE 100
34.9	1029	3.19	40.1	9.0	EP305L2	--	112M-4	OK	PAGE 110
36.1	963	1.32	38.8	7.5	EP301L3	--	112M-4	OK	PAGE 90
36.6	950	2.73	38.3	14.0	--	EP303R3	112M-4	OK	PAGE 100
36.6	950	3.08	38.3	14.0	--	EP305R3	112M-4	OK	PAGE 110
43.6	824	2.13	32.1	9.0	EP303L2	--	112M-4	OK	PAGE 100
43.8	821	0.87	32.0	7.5	EP300L2	--	112M-4	OK	PAGE 80
43.8	821	1.60	32.0	7.5	EP301L2	--	112M-4	OK	PAGE 90
45.4	766	0.92	30.8	12.0	--	EP300R3	112M-4	OK	PAGE 80
45.4	766	1.69	30.8	12.0	--	EP301R3	112M-4	OK	PAGE 90
46.7	769	2.45	30.0	9.0	EP303L2	--	112M-4	OK	PAGE 100
48.0	724	3.30	29.1	14.0	--	EP305R3	112M-4	OK	PAGE 110

EP300 series gear motor

P1=4.0KW n1=1400 min⁻¹

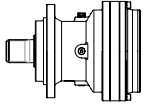
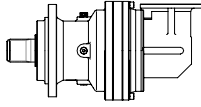
n ₂ (min ⁻¹)	M ₂ (N.m)	S	I 1:	P _t (KW)			IEC Motor type	Check Thermal	Dimension
								Power Pt >= P1	Page Number
48.0	724	3.36	29.1	14.0	--	EP303R3	112M-4	OK	PAGE 100
54.6	658	1.06	25.6	7.5	EP300L2	--	112M-4	OK	PAGE 80
54.6	658	1.74	25.6	7.5	EP301L2	--	112M-4	OK	PAGE 90
55.0	632	2.86	25.4	14.0	--	EP305R3	112M-4	OK	PAGE 110
55.0	632	3.14	25.4	14.0	--	EP303R3	112M-4	OK	PAGE 100
55.6	646	2.77	25.2	9.0	EP303L2	--	112M-4	OK	PAGE 100
57.8	621	2.77	24.2	9.0	EP303L2	--	112M-4	OK	PAGE 100
59.6	583	1.10	23.5	12.0	--	EP300R3	112M-4	OK	PAGE 80
59.6	583	1.76	23.5	12.0	--	EP301R3	112M-4	OK	PAGE 90
70.9	507	1.32	19.8	7.5	EP300L2	--	112M-4	OK	PAGE 80
70.9	507	2.13	19.8	7.5	EP301L2	--	112M-4	OK	PAGE 90
80.1	448	3.04	17.5	18.0	--	EP303R2	112M-4	OK	PAGE 100
80.1	448	3.04	17.5	18.0	--	EP305R2	112M-4	OK	PAGE 110
93.1	386	1.60	15.0	7.5	EP300L2	--	112M-4	OK	PAGE 80
93.1	386	2.55	15.0	7.5	EP301L2	--	112M-4	OK	PAGE 90
94.9	379	1.06	14.8	12.0	--	EP300R2	112M-4	OK	PAGE 80
94.9	379	2.34	14.8	12.0	--	EP301R2	112M-4	OK	PAGE 90
118	303	1.60	11.8	12.0	--	EP300R2	112M-4	OK	PAGE 80
118	303	2.98	11.8	12.0	--	EP301R2	112M-4	OK	PAGE 90
122	294	1.91	11.5	7.5	EP300L2	--	112M-4	OK	PAGE 80
122	294	3.19	11.5	7.5	EP301L2	--	112M-4	OK	PAGE 90
154	234	3.19	9.1	12.0	--	EP300R2	112M-4	OK	PAGE 80
154	234	3.19	9.1	12.0	--	EP301R2	112M-4	OK	PAGE 90
194	191	2.27	7.2	7.5	EP300L1	--	112M-4	OK	PAGE 80
194	191	2.27	7.2	7.5	EP300L1	--	112M-4	OK	PAGE 80
202	178	3.19	6.9	12.0	--	EP300R2	112M-4	OK	PAGE 80
202	178	3.19	6.9	12.0	--	EP301R2	112M-4	OK	PAGE 90
243	153	3.09	5.8	7.5	EP300L1	--	112M-4	OK	PAGE 80

EP300 series gear motor

P1=5.5KW n1=1400 min⁻¹

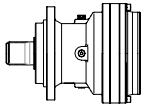
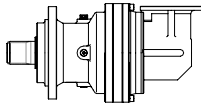
n ₂ (min ⁻¹)	M ₂ (N.m)	S	I 1:	P _t (KW)			IEC Motor type	Check Thermal	Dimension
								Power Pt >= P1	Page Number
0.7	67804	1.16	2054	18.0	EP315L4	--	132S-4	OK	PAGE 180
0.8	57131	1.49	1731	18.0	EP315L4	--	132S-4	OK	PAGE 180
0.89	51750	0.94	1568	11.0	EP313L4	--	132S-4	OK	PAGE 170
1.0	46615	1.74	1412	18.0	EP315L4	--	132S-4	OK	PAGE 180
1.0	45876	2.56	1390	18.0	EP316L4	--	132S-4	OK	PAGE 190
1.1	43604	1.11	1321	11.0	EP313L4	--	132S-4	OK	PAGE 170
1.1	40571	1.74	1229	18.0	EP315L4	--	132S-4	OK	PAGE 180
1.2	38655	2.98	1171	18.0	EP316L4	--	132S-4	OK	PAGE 190
1.3	36500	0.99	1106	11.0	EP311L4	--	132S-4	OK	PAGE 160
1.3	35631	1.32	1079	11.0	EP313L4	--	132S-4	OK	PAGE 170
1.4	34185	2.31	1036	18.0	EP315L4	--	132S-4	OK	PAGE 180
1.6	29247	1.21	886	11.0	EP311L4	--	132S-4	OK	PAGE 160
1.6	28650	2.89	868	18.0	EP315L4	--	132S-4	OK	PAGE 180

EP300 series gear motor

P1=5.5KW n1=1400 min⁻¹

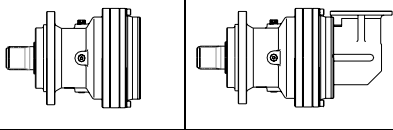
n ₂ (min ⁻¹)	M ₂ (N.m)	S	I 1:	P _t (KW)			IEC Motor type	Check Thermal Power Pt >= P1	Dimension Page Number
1.6	28550	1.49	865	11.0	EP313L4	--	132S-4	OK	PAGE 170
1.8	26247	1.32	795	11.0	EP311L4	--	132S-4	OK	PAGE 160
1.8	25622	1.65	776	11.0	EP313L4	--	132S-4	OK	PAGE 170
1.8	25483	2.64	772	40.0	--	EP315R4	132S-4	OK	PAGE 180
2.0	23527	0.93	713	11.0	EP310L4	--	132S-4	OK	PAGE 150
2.1	21998	1.57	666	11.0	EP311L4	--	132S-4	OK	PAGE 160
2.1	21839	1.82	662	22.0	--	EP313R4	132S-4	OK	PAGE 170
2.2	21474	2.07	650	11.0	EP313L4	--	132S-4	OK	PAGE 170
2.2	21472	3.47	650	40.0	--	EP315R4	132S-4	OK	PAGE 180
2.3	19952	1.07	604	11.0	EP310L4	--	132S-4	OK	PAGE 150
2.4	19522	0.91	591	7.5	EP309L4	--	132S-4	OK	PAGE 140
2.5	18592	0.99	563	14.0	--	EP310R4	132S-4	OK	PAGE 150
2.5	18478	1.85	560	11.0	EP311L4	--	132S-4	OK	PAGE 160
2.5	18418	2.48	558	22.0	--	EP313R4	132S-4	OK	PAGE 170
2.6	18038	2.48	546	11.0	EP313L4	--	132S-4	OK	PAGE 170
2.6	17914	1.57	543	22.0	--	EP311R4	132S-4	OK	PAGE 160
2.8	16760	1.40	508	11.0	EP310L4	--	132S-4	OK	PAGE 150
2.8	16685	1.27	505	14.0	--	EP310R4	132S-4	OK	PAGE 150
3.0	15643	1.07	474	7.5	EP309L4	--	132S-4	OK	PAGE 140
3.0	15519	2.89	470	22.0	--	EP313R4	132S-4	OK	PAGE 170
3.1	15094	2.20	457	22.0	--	EP311R4	132S-4	OK	PAGE 160
3.2	14398	2.31	436	11.0	EP311L4	--	132S-4	OK	PAGE 160
3.2	14252	1.16	432	14.0	--	EP309R4	132S-4	OK	PAGE 140
3.3	14078	1.57	426	11.0	EP310L4	--	132S-4	OK	PAGE 150
3.3	14078	3.64	426	11.0	EP313L4	--	132S-4	OK	PAGE 170
3.4	13634	1.54	413	14.0	--	EP310R4	132S-4	OK	PAGE 150
3.6	12718	2.56	385	22.0	--	EP311R4	132S-4	OK	PAGE 160
3.6	12681	3.47	384	22.0	--	EP313R4	132S-4	OK	PAGE 170
3.8	12236	1.69	371	14.0	--	EP310R4	132S-4	OK	PAGE 150
3.8	12051	1.32	365	7.5	EP309L4	--	132S-4	OK	PAGE 140
4.0	11420	1.32	346	14.0	--	EP309R4	132S-4	OK	PAGE 140
4.2	11092	2.98	336	11.0	EP311L4	--	132S-4	OK	PAGE 160
4.2	11253	1.52	330	18.0	EP310L3	--	132S-4	OK	PAGE 150
4.3	10846	1.98	329	11.0	EP310L4	--	132S-4	OK	PAGE 150
4.4	10450	1.90	317	14.0	--	EP310R4	132S-4	OK	PAGE 150
4.4	10392	3.07	315	22.0	--	EP311R4	132S-4	OK	PAGE 160
4.5	10249	0.91	310	14.0	--	EP307R4	132S-4	OK	PAGE 130
4.5	10249	1.49	310	14.0	--	EP309R4	132S-4	OK	PAGE 140
4.9	9464	3.47	287	11.0	EP311L4	--	132S-4	OK	PAGE 160
5.0	9326	3.39	283	22.0	--	EP311R4	132S-4	OK	PAGE 160
5.0	9177	0.99	278	7.5	EP307L4	--	132S-4	OK	PAGE 130
5.0	9177	1.65	278	7.5	EP309L4	--	132S-4	OK	PAGE 140
5.2	9182	1.84	269	18.0	EP310L3	--	132S-4	OK	PAGE 150
5.2	8862	2.15	268	14.0	--	EP310R4	132S-4	OK	PAGE 150
5.3	9036	2.56	265	18.0	EP311L3	--	132S-4	OK	PAGE 160
5.3	8698	1.02	263	6.0	EP306L4	--	132S-4	OK	PAGE 120
5.4	8590	0.99	260	14.0	--	EP307R4	132S-4	OK	PAGE 130
5.4	8590	1.74	260	14.0	--	EP309R4	132S-4	OK	PAGE 140
5.4	8798	1.12	258	11.0	EP307L3	--	132S-4	OK	PAGE 130
5.4	8798	1.28	258	11.0	EP309L3	--	132S-4	OK	PAGE 140
6.2	7444	2.48	226	14.0	--	EP310R4	132S-4	OK	PAGE 150

EP300 series gear motor

P1=5.5KW n1=1400 min⁻¹

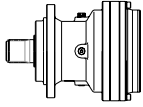
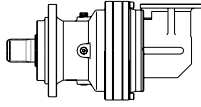
n ₂ (min ⁻¹)	M ₂ (N.m)	S	I 1:	P _t (KW)			IEC Motor type	Check Thermal	Dimension
								Power Pt >= P1	Page Number
6.3	7614	3.52	223	18.0	EP311L3	--	132S-4	OK	PAGE 160
6.4	7503	2.24	220	18.0	EP310L3	--	132S-4	OK	PAGE 150
6.4	7215	1.16	219	14.0	--	EP307R4	132S-4	OK	PAGE 130
6.4	7215	1.98	219	14.0	--	EP309R4	132S-4	OK	PAGE 140
6.6	7189	1.28	211	11.0	EP307L3	--	132S-4	OK	PAGE 130
6.6	7189	2.08	211	11.0	EP309L3	--	132S-4	OK	PAGE 140
6.7	6872	1.24	208	12.0	--	EP306R4	132S-4	OK	PAGE 120
6.9	6701	1.32	203	6.0	EP306L4	--	132S-4	OK	PAGE 120
7.1	6733	3.04	197	18.0	EP310L3	--	132S-4	OK	PAGE 150
7.4	6253	2.81	189	14.0	--	EP310R4	132S-4	OK	PAGE 150
8.3	5761	1.60	169	11.0	EP307L3	--	132S-4	OK	PAGE 130
8.3	5761	2.56	169	11.0	EP309L3	--	132S-4	OK	PAGE 140
8.3	5558	1.49	168	14.0	--	EP307R4	132S-4	OK	PAGE 130
8.3	5558	2.48	168	14.0	--	EP309R4	132S-4	OK	PAGE 140
8.4	5697	1.10	167	7.5	EP306L3	--	132S-4	OK	PAGE 120
8.7	5502	3.52	161	18.0	EP310L3	--	132S-4	OK	PAGE 150
8.7	5294	1.57	160	12.0	--	EP306R4	132S-4	OK	PAGE 120
9.2	5170	1.89	151	11.0	EP307L3	--	132S-4	OK	PAGE 130
9.2	5170	2.72	151	11.0	EP309L3	--	132S-4	OK	PAGE 140
9.6	4794	3.47	145	14.0	--	EP310R4	132S-4	OK	PAGE 150
9.8	4866	1.44	143	7.5	EP306L3	--	132S-4	OK	PAGE 120
10.0	4772	0.99	140	7.5	EP305L3	--	132S-4	OK	PAGE 110
10.9	4233	1.82	128	14.0	--	EP307R4	132S-4	OK	PAGE 130
10.9	4233	2.56	128	14.0	--	EP309R4	132S-4	OK	PAGE 140
11.0	4333	2.24	127	11.0	EP307L3	--	132S-4	OK	PAGE 130
11.0	4333	3.20	127	11.0	EP309L3	--	132S-4	OK	PAGE 140
11.3	4229	3.20	124	20.0	--	EP310R3	132S-4	OK	PAGE 150
11.5	4031	1.87	122	12.0	--	EP306R4	132S-4	OK	PAGE 120
12.4	3733	1.01	113	12.0	--	EP305R4	132S-4	OK	PAGE 110
12.5	3695	1.98	112	14.0	--	EP307R4	132S-4	OK	PAGE 130
12.9	3716	1.92	109	20.0	--	EP307R3	132S-4	OK	PAGE 130
12.9	3716	2.56	109	20.0	--	EP309R3	132S-4	OK	PAGE 140
13.0	3676	1.12	108	7.5	EP305L3	--	132S-4	OK	PAGE 110
13.1	3640	2.56	107	11.0	EP307L3	--	132S-4	OK	PAGE 130
13.8	3466	1.76	102	7.5	EP306L3	--	132S-4	OK	PAGE 120
13.9	3435	0.85	101	14.0	--	EP305R3	132S-4	OK	PAGE 110
14.1	3383	1.44	99.1	14.0	--	EP306R3	132S-4	OK	PAGE 120
14.2	3256	1.16	98.6	12.0	--	EP305R4	132S-4	OK	PAGE 110
15.0	3091	2.31	93.6	12.0	--	EP306R4	132S-4	OK	PAGE 120
15.3	3131	2.40	91.7	20.0	--	EP307R3	132S-4	OK	PAGE 130
15.3	3131	2.88	91.7	20.0	--	EP309R3	132S-4	OK	PAGE 140
17.0	2807	1.12	82.2	14.0	--	EP305R3	132S-4	OK	PAGE 110
17.0	2804	3.20	82.1	11.0	EP307L3	--	132S-4	OK	PAGE 130
17.1	2800	1.44	82.0	7.5	EP305L3	--	132S-4	OK	PAGE 110
17.3	2761	2.08	80.9	14.0	--	EP306R3	132S-4	OK	PAGE 120
17.9	2670	2.08	78.2	7.5	EP306L3	--	132S-4	OK	PAGE 120
18.7	2559	2.88	75.0	20.0	--	EP307R3	132S-4	OK	PAGE 130
18.7	2559	3.20	75.0	20.0	--	EP309R3	132S-4	OK	PAGE 140
19.6	2444	0.88	71.6	7.5	EP303L3	--	132S-4	OK	PAGE 100
19.6	2444	1.44	71.6	7.5	EP305L3	--	132S-4	OK	PAGE 110
20.8	2296	3.20	67.3	20.0	--	EP307R3	132S-4	OK	PAGE 130

EP300 series gear motor

P1=5.5KW n1=1400 min⁻¹

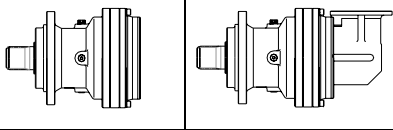
n ₂ (min ⁻¹)	M ₂ (N.m)	S	I 1:	P _t (KW)			IEC Motor type	Check Thermal Power Pt >= P1	Dimension Page Number
20.8	2296	3.52	67.3	20.0	--	EP309R3	132S-4	OK	PAGE 140
21.2	2256	2.40	66.1	14.0	--	EP306R3	132S-4	OK	PAGE 120
21.2	2249	1.44	65.9	14.0	--	EP305R3	132S-4	OK	PAGE 110
22.2	2157	0.99	63.2	7.5	EP303L3	--	132S-4	OK	PAGE 100
22.2	2157	1.44	63.2	7.5	EP305L3	--	132S-4	OK	PAGE 110
22.8	2099	0.90	61.5	14.0	--	EP303R3	132S-4	OK	PAGE 100
22.8	2099	1.60	61.5	14.0	--	EP305R3	132S-4	OK	PAGE 110
23.5	2034	2.64	59.6	7.5	EP306L3	--	132S-4	OK	PAGE 120
23.6	2024	2.64	59.3	14.0	--	EP306R3	132S-4	OK	PAGE 120
23.7	2019	1.60	59.1	14.0	--	EP305R3	132S-4	OK	PAGE 110
24.8	1925	3.20	56.4	20.0	--	EP309R3	132S-4	OK	PAGE 140
24.8	1925	3.52	56.4	20.0	--	EP307R3	132S-4	OK	PAGE 130
25.4	1883	1.12	55.2	7.5	EP303L3	--	132S-4	OK	PAGE 100
25.4	1883	1.60	55.2	7.5	EP305L3	--	132S-4	OK	PAGE 110
27.0	1771	1.09	51.9	14.0	--	EP303R3	132S-4	OK	PAGE 100
27.1	1764	1.47	51.7	14.0	--	EP303R3	132S-4	OK	PAGE 100
27.1	1764	1.92	51.7	14.0	--	EP305R3	132S-4	OK	PAGE 110
27.6	1729	3.04	50.6	14.0	--	EP306R3	132S-4	OK	PAGE 120
28.2	1696	1.39	49.7	14.0	--	EP303R3	132S-4	OK	PAGE 100
28.2	1696	1.92	49.7	14.0	--	EP305R3	132S-4	OK	PAGE 110
28.5	1731	0.93	49.1	9.0	EP303L2	--	132S-4	OK	PAGE 100
28.5	1731	1.55	49.1	9.0	EP305L2	--	132S-4	OK	PAGE 110
29.0	1705	2.48	48.3	13.0	EP306L2	--	132S-4	OK	PAGE 120
29.1	1642	1.28	48.1	7.5	EP303L3	--	132S-4	OK	PAGE 100
29.1	1642	1.92	48.1	7.5	EP305L3	--	132S-4	OK	PAGE 110
29.6	1617	3.20	47.4	20.0	--	EP309R3	132S-4	OK	PAGE 140
30.7	1559	3.36	45.7	7.5	EP306L3	--	132S-4	OK	PAGE 120
33.9	1411	3.52	41.3	20.0	--	EP309R3	132S-4	OK	PAGE 140
34.6	1382	1.01	40.5	12.0	--	EP301R3	132S-4	OK	PAGE 90
34.9	1415	1.24	40.1	9.0	EP303L2	--	132S-4	OK	PAGE 100
34.9	1415	2.32	40.1	9.0	EP305L2	--	132S-4	OK	PAGE 110
35.5	1391	3.40	39.4	13.0	EP306L2	--	132S-4	OK	PAGE 120
36.1	1324	0.96	38.8	7.5	EP301L3	--	132S-4	OK	PAGE 90
36.6	1306	1.98	38.3	14.0	--	EP303R3	132S-4	OK	PAGE 100
36.6	1306	2.24	38.3	14.0	--	EP305R3	132S-4	OK	PAGE 110
43.6	1133	1.55	32.1	9.0	EP303L2	--	132S-4	OK	PAGE 100
43.6	1133	2.79	32.1	9.0	EP305L2	--	132S-4	OK	PAGE 110
43.8	1128	1.16	32.0	7.5	EP301L2	--	132S-4	OK	PAGE 90
45.4	1053	1.23	30.8	12.0	--	EP301R3	132S-4	OK	PAGE 90
46.7	1058	1.78	30.0	9.0	EP303L2	--	132S-4	OK	PAGE 100
46.7	1058	3.02	30.0	9.0	EP305L2	--	132S-4	OK	PAGE 110
48.0	995	2.40	29.1	14.0	--	EP305R3	132S-4	OK	PAGE 110
48.0	995	2.45	29.1	14.0	--	EP303R3	132S-4	OK	PAGE 100
48.5	1017	1.86	28.8	9.0	EP303L2	--	132S-4	OK	PAGE 100
48.5	1017	3.09	28.8	9.0	EP305L2	--	132S-4	OK	PAGE 110
54.6	904	1.27	25.6	7.5	EP301L2	--	132S-4	OK	PAGE 90
55.0	868	2.08	25.4	14.0	--	EP305R3	132S-4	OK	PAGE 110
55.0	868	2.29	25.4	14.0	--	EP303R3	132S-4	OK	PAGE 100
55.6	889	2.01	25.2	9.0	EP303L2	--	132S-4	OK	PAGE 100
55.6	889	3.40	25.2	9.0	EP305L2	--	132S-4	OK	PAGE 110
57.8	854	2.01	24.2	9.0	EP303L2	--	132S-4	OK	PAGE 100

EP300 series gear motor

P1=5.5KW n1=1400 min⁻¹

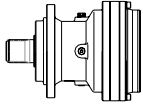
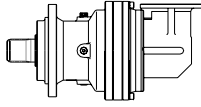
n ₂ (min ⁻¹)	M ₂ (N.m)	S	I 1:	P _t (KW)			IEC Motor type	Check Thermal	Dimension
								Power Pt >= P1	Page Number
57.8	854	3.40	24.2	9.0	EP305L2	--	132S-4	OK	PAGE 110
59.6	802	1.28	23.5	12.0	--	EP301R3	132S-4	OK	PAGE 90
70.9	697	0.96	19.8	7.5	EP300L2	--	132S-4	OK	PAGE 80
70.9	697	1.55	19.8	7.5	EP301L2	--	132S-4	OK	PAGE 90
75.0	658	2.63	18.7	9.0	EP303L2	--	132S-4	OK	PAGE 100
80.1	616	2.21	17.5	18.0	--	EP303R2	132S-4	OK	PAGE 100
80.1	616	2.21	17.5	18.0	--	EP305R2	132S-4	OK	PAGE 110
93.1	530	1.16	15.0	7.5	EP300L2	--	132S-4	OK	PAGE 80
93.1	530	1.86	15.0	7.5	EP301L2	--	132S-4	OK	PAGE 90
94.9	520	1.70	14.8	12.0	--	EP301R2	132S-4	OK	PAGE 90
98.1	503	2.92	14.3	18.0	--	EP303R2	132S-4	OK	PAGE 100
98.1	503	2.92	14.3	18.0	--	EP305R2	132S-4	OK	PAGE 110
98.5	501	3.40	14.2	9.0	EP303L2	--	132S-4	OK	PAGE 100
118	417	1.16	11.8	12.0	--	EP300R2	132S-4	OK	PAGE 80
118	417	2.17	11.8	12.0	--	EP301R2	132S-4	OK	PAGE 90
122	404	1.39	11.5	7.5	EP300L2	--	132S-4	OK	PAGE 80
122	404	2.32	11.5	7.5	EP301L2	--	132S-4	OK	PAGE 90
154	321	2.32	9.1	12.0	--	EP300R2	132S-4	OK	PAGE 80
154	321	2.32	9.1	12.0	--	EP301R2	132S-4	OK	PAGE 90
194	262	1.65	7.2	7.5	EP300L1	--	132S-4	OK	PAGE 80
194	262	1.65	7.2	7.5	EP300L1	--	132S-4	OK	PAGE 80
194	262	2.70	7.2	7.5	EP301L1	--	132S-4	OK	PAGE 90
202	245	2.32	6.9	12.0	--	EP300R2	132S-4	OK	PAGE 80
202	245	2.32	6.9	12.0	--	EP301R2	132S-4	OK	PAGE 90
243	210	2.25	5.8	7.5	EP300L1	--	132S-4	OK	PAGE 80
315	162	3.00	4.4	7.5	EP300L1	--	132S-4	OK	PAGE 80
414	123	3.00	3.4	7.5	EP300L1	--	132S-4	OK	PAGE 80

EP300 series gear motor

P1=7.5KW n1=1400 min⁻¹

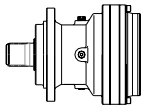
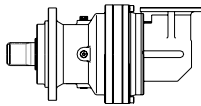
n ₂ (min ⁻¹)	M ₂ (N.m)	S	I 1:	P _t (KW)			IEC Motor type	Check Thermal	Dimension
								Power Pt >= P1	Page Number
0.7	92460	0.85	2054	18.0	EP315L4	--	132M-4	OK	PAGE 180
0.8	77906	1.09	1731	18.0	EP315L4	--	132M-4	OK	PAGE 180
1.0	63566	1.27	1412	18.0	EP315L4	--	132M-4	OK	PAGE 180
1.0	62558	1.88	1390	18.0	EP316L4	--	132M-4	OK	PAGE 190
1.1	55324	1.27	1229	18.0	EP315L4	--	132M-4	OK	PAGE 180
1.2	52711	2.18	1171	18.0	EP316L4	--	132M-4	OK	PAGE 190
1.3	48588	0.97	1079	11.0	EP313L4	--	132M-4	OK	PAGE 170
1.4	46615	1.70	1036	18.0	EP315L4	--	132M-4	OK	PAGE 180
1.4	44177	2.67	981	18.0	EP316L4	--	132M-4	OK	PAGE 190
1.6	39068	2.12	868	18.0	EP315L4	--	132M-4	OK	PAGE 180
1.6	38932	1.09	865	11.0	EP313L4	--	132M-4	OK	PAGE 170
1.7	37223	3.03	827	18.0	EP316L4	--	132M-4	OK	PAGE 190
1.8	35792	0.97	795	11.0	EP311L4	--	132M-4	OK	PAGE 160
1.8	34939	1.21	776	11.0	EP313L4	--	132M-4	OK	PAGE 170
1.8	34750	1.94	772	40.0	--	EP315R4	132M-4	OK	PAGE 180

EP300 series gear motor

P1=7.5KW n1=1400 min⁻¹

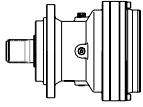
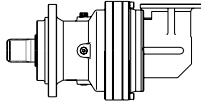
n ₂ (min ⁻¹)	M ₂ (N.m)	S	I 1:	P _t (KW)			IEC Motor type	Check Thermal	Dimension
								Power Pt >= P1	Page Number
1.8	34735	3.39	772	45.0	--	EP316R4	132M-4	OK	PAGE 190
2.1	30417	3.64	676	18.0	EP316L4	--	132M-4	OK	PAGE 190
2.1	29997	1.15	666	11.0	EP311L4	--	132M-4	OK	PAGE 160
2.1	29780	1.33	662	22.0	--	EP313R4	132M-4	OK	PAGE 170
2.2	29283	1.52	650	11.0	EP313L4	--	132M-4	OK	PAGE 170
2.2	29280	2.55	650	40.0	--	EP315R4	132M-4	OK	PAGE 180
2.2	28650	2.79	636	18.0	EP315L4	--	132M-4	OK	PAGE 180
2.5	25197	1.36	560	11.0	EP311L4	--	132M-4	OK	PAGE 160
2.5	25115	1.82	558	22.0	--	EP313R4	132M-4	OK	PAGE 170
2.6	24597	1.82	546	11.0	EP313L4	--	132M-4	OK	PAGE 170
2.6	24468	3.15	544	18.0	EP315L4	--	132M-4	OK	PAGE 180
2.6	24428	1.15	543	22.0	--	EP311R4	132M-4	OK	PAGE 160
2.6	23890	2.79	531	40.0	--	EP315R4	132M-4	OK	PAGE 180
2.8	22855	1.03	508	11.0	EP310L4	--	132M-4	OK	PAGE 150
2.8	22753	0.93	505	14.0	--	EP310R4	132M-4	OK	PAGE 150
3.0	21162	2.12	470	22.0	--	EP313R4	132M-4	OK	PAGE 170
3.0	20792	3.15	462	40.0	--	EP315R4	132M-4	OK	PAGE 180
3.0	20751	3.64	461	18.0	EP315L4	--	132M-4	OK	PAGE 180
3.1	20582	1.61	457	22.0	--	EP311R4	132M-4	OK	PAGE 160
3.2	19634	1.70	436	11.0	EP311L4	--	132M-4	OK	PAGE 160
3.2	19435	0.85	432	14.0	--	EP309R4	132M-4	OK	PAGE 140
3.3	19198	1.15	426	11.0	EP310L4	--	132M-4	OK	PAGE 150
3.3	19198	2.67	426	11.0	EP313L4	--	132M-4	OK	PAGE 170
3.4	18592	1.13	413	14.0	--	EP310R4	132M-4	OK	PAGE 150
3.6	17343	1.88	385	22.0	--	EP311R4	132M-4	OK	PAGE 160
3.6	17292	2.55	384	22.0	--	EP313R4	132M-4	OK	PAGE 170
3.8	16685	1.24	371	14.0	--	EP310R4	132M-4	OK	PAGE 150
3.8	16433	0.97	365	7.5	EP309L4	--	132M-4	OK	PAGE 140
4.0	15573	0.97	346	14.0	--	EP309R4	132M-4	OK	PAGE 140
4.1	15519	2.79	345	22.0	--	EP313R4	132M-4	OK	PAGE 170
4.2	15126	2.18	336	11.0	EP311L4	--	132M-4	OK	PAGE 160
4.2	15345	1.11	330	18.0	EP310L3	--	132M-4	OK	PAGE 150
4.3	14789	1.45	329	11.0	EP310L4	--	132M-4	OK	PAGE 150
4.3	14789	3.39	329	11.0	EP313L4	--	132M-4	OK	PAGE 170
4.4	14250	1.39	317	14.0	--	EP310R4	132M-4	OK	PAGE 150
4.4	14171	2.25	315	22.0	--	EP311R4	132M-4	OK	PAGE 160
4.5	13976	1.09	310	14.0	--	EP309R4	132M-4	OK	PAGE 140
4.8	13006	3.27	289	22.0	--	EP313R4	132M-4	OK	PAGE 170
4.9	12905	2.55	287	11.0	EP311L4	--	132M-4	OK	PAGE 160
5.0	12718	2.48	283	22.0	--	EP311R4	132M-4	OK	PAGE 160
5.0	12598	3.64	280	11.0	EP313L4	--	132M-4	OK	PAGE 170
5.0	12514	1.21	278	7.5	EP309L4	--	132M-4	OK	PAGE 140
5.2	12521	1.35	269	18.0	EP310L3	--	132M-4	OK	PAGE 150
5.2	12085	1.58	268	14.0	--	EP310R4	132M-4	OK	PAGE 150
5.3	12322	1.88	265	18.0	EP311L3	--	132M-4	OK	PAGE 160
5.4	11713	1.27	260	14.0	--	EP309R4	132M-4	OK	PAGE 140
5.4	12018	3.63	258	18.0	EP313L3	--	132M-4	OK	PAGE 170
5.4	11998	0.94	258	11.0	EP309L3	--	132M-4	OK	PAGE 140
5.5	11519	2.79	256	11.0	EP311L4	--	132M-4	OK	PAGE 160
5.6	11263	3.64	250	11.0	EP313L4	--	132M-4	OK	PAGE 170
5.9	10659	2.79	237	22.0	--	EP311R4	132M-4	OK	PAGE 160

EP300 series gear motor

P1=7.5KW n1=1400 min⁻¹

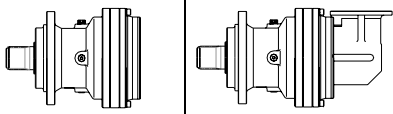
n ₂ (min ⁻¹)	M ₂ (N.m)	S	I 1:	P _t (KW)			IEC Motor type	Check Thermal Power Pt >= P1	Dimension Page Number
6.2	10151	1.82	226	14.0	--	EP310R4	132M-4	OK	PAGE 150
6.3	10383	2.58	223	18.0	EP311L3	--	132M-4	OK	PAGE 160
6.4	10231	1.64	220	18.0	EP310L3	--	132M-4	OK	PAGE 150
6.4	9839	0.85	219	14.0	--	EP307R4	132M-4	OK	PAGE 130
6.4	9839	1.45	219	14.0	--	EP309R4	132M-4	OK	PAGE 140
6.6	9804	0.94	211	11.0	EP307L3	--	132M-4	OK	PAGE 130
6.6	9804	1.52	211	11.0	EP309L3	--	132M-4	OK	PAGE 140
6.7	9370	0.91	208	12.0	--	EP306R4	132M-4	OK	PAGE 120
7.0	8953	3.15	199	22.0	--	EP311R4	132M-4	OK	PAGE 160
7.1	9182	2.23	197	18.0	EP310L3	--	132M-4	OK	PAGE 150
7.4	8527	2.06	189	14.0	--	EP310R4	132M-4	OK	PAGE 150
7.4	8748	2.93	188	18.0	EP311L3	--	132M-4	OK	PAGE 160
8.1	7816	3.52	174	22.0	--	EP311R4	132M-4	OK	PAGE 160
8.3	7856	1.17	169	11.0	EP307L3	--	132M-4	OK	PAGE 130
8.3	7856	1.88	169	11.0	EP309L3	--	132M-4	OK	PAGE 140
8.3	7580	1.09	168	14.0	--	EP307R4	132M-4	OK	PAGE 130
8.3	7580	1.82	168	14.0	--	EP309R4	132M-4	OK	PAGE 140
8.7	7503	2.58	161	18.0	EP310L3	--	132M-4	OK	PAGE 150
8.7	7219	1.15	160	12.0	--	EP306R4	132M-4	OK	PAGE 120
9.1	7149	3.28	154	18.0	EP311L3	--	132M-4	OK	PAGE 160
9.2	7050	1.38	151	11.0	EP307L3	--	132M-4	OK	PAGE 130
9.2	7050	1.99	151	11.0	EP309L3	--	132M-4	OK	PAGE 140
9.6	6537	2.55	145	14.0	--	EP310R4	132M-4	OK	PAGE 150
9.7	6733	2.81	145	18.0	EP310L3	--	132M-4	OK	PAGE 150
9.8	6635	1.05	143	7.5	EP306L3	--	132M-4	OK	PAGE 120
10.2	6415	3.52	138	18.0	EP311L3	--	132M-4	OK	PAGE 160
10.9	5772	1.33	128	14.0	--	EP307R4	132M-4	OK	PAGE 130
10.9	5772	1.88	128	14.0	--	EP309R4	132M-4	OK	PAGE 140
11.0	5908	1.64	127	11.0	EP307L3	--	132M-4	OK	PAGE 130
11.0	5908	2.34	127	11.0	EP309L3	--	132M-4	OK	PAGE 140
11.3	5767	2.34	124	20.0	--	EP310R3	132M-4	OK	PAGE 150
11.3	5750	3.28	124	18.0	EP310L3	--	132M-4	OK	PAGE 150
11.5	5497	1.37	122	12.0	--	EP306R4	132M-4	OK	PAGE 120
12.5	5039	1.45	112	14.0	--	EP307R4	132M-4	OK	PAGE 130
12.9	5068	1.41	109	20.0	--	EP307R3	132M-4	OK	PAGE 130
12.9	5068	1.88	109	20.0	--	EP309R3	132M-4	OK	PAGE 140
13.1	4963	1.88	107	11.0	EP307L3	--	132M-4	OK	PAGE 130
13.1	4963	2.70	107	11.0	EP309L3	--	132M-4	OK	PAGE 140
13.8	4727	1.29	102	7.5	EP306L3	--	132M-4	OK	PAGE 120
13.8	4706	2.81	101	20.0	--	EP310R3	132M-4	OK	PAGE 150
14.1	4614	1.05	99.1	14.0	--	EP306R3	132M-4	OK	PAGE 120
15.0	4215	1.70	93.6	12.0	--	EP306R4	132M-4	OK	PAGE 120
15.3	4270	1.76	91.7	20.0	--	EP307R3	132M-4	OK	PAGE 130
15.3	4270	2.11	91.7	20.0	--	EP309R3	132M-4	OK	PAGE 140
16.2	4019	3.16	86.3	20.0	--	EP310R3	132M-4	OK	PAGE 150
17.0	3823	2.34	82.1	11.0	EP307L3	--	132M-4	OK	PAGE 130
17.0	3823	3.28	82.1	11.0	EP309L3	--	132M-4	OK	PAGE 140
17.1	3818	1.05	82.0	7.5	EP305L3	--	132M-4	OK	PAGE 110
17.3	3765	1.52	80.9	14.0	--	EP306R3	132M-4	OK	PAGE 120
17.9	3641	1.52	78.2	7.5	EP306L3	--	132M-4	OK	PAGE 120
18.7	3489	2.11	75.0	20.0	--	EP307R3	132M-4	OK	PAGE 130

EP300 series gear motor

P1=7.5KW n1=1400 min⁻¹

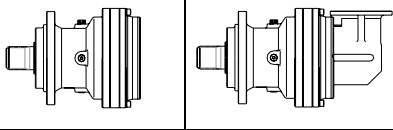
n ₂ (min ⁻¹)	M ₂ (N.m)	S	I 1:	P _t (KW)			IEC Motor type	Check Thermal Power Pt >= P1	Dimension Page Number
18.7	3489	2.34	75.0	20.0	--	EP309R3	132M-4	OK	PAGE 140
19.6	3333	1.05	71.6	7.5	EP305L3	--	132M-4	OK	PAGE 110
20.8	3131	2.34	67.3	20.0	--	EP307R3	132M-4	OK	PAGE 130
20.8	3131	2.58	67.3	20.0	--	EP309R3	132M-4	OK	PAGE 140
21.2	3076	1.76	66.1	14.0	--	EP306R3	132M-4	OK	PAGE 120
21.2	3067	1.05	65.9	14.0	--	EP305R3	132M-4	OK	PAGE 110
22.2	2941	1.05	63.2	7.5	EP305L3	--	132M-4	OK	PAGE 110
22.4	2912	2.93	62.5	11.0	EP307L3	--	132M-4	OK	PAGE 130
22.8	2863	1.17	61.5	14.0	--	EP305R3	132M-4	OK	PAGE 110
23.5	2773	1.93	59.6	7.5	EP306L3	--	132M-4	OK	PAGE 120
23.6	2761	1.93	59.3	14.0	--	EP306R3	132M-4	OK	PAGE 120
23.7	2753	1.17	59.1	14.0	--	EP305R3	132M-4	OK	PAGE 110
24.8	2624	2.34	56.4	20.0	--	EP309R3	132M-4	OK	PAGE 140
24.8	2624	2.58	56.4	20.0	--	EP307R3	132M-4	OK	PAGE 130
25.4	2568	1.17	55.2	7.5	EP305L3	--	132M-4	OK	PAGE 110
25.6	2542	3.28	54.6	11.0	EP307L3	--	132M-4	OK	PAGE 130
27.1	2405	1.08	51.7	14.0	--	EP303R3	132M-4	OK	PAGE 100
27.1	2405	1.41	51.7	14.0	--	EP305R3	132M-4	OK	PAGE 110
27.6	2358	2.23	50.6	14.0	--	EP306R3	132M-4	OK	PAGE 120
28.2	2312	1.02	49.7	14.0	--	EP303R3	132M-4	OK	PAGE 100
28.2	2312	1.41	49.7	14.0	--	EP305R3	132M-4	OK	PAGE 110
28.5	2361	1.13	49.1	9.0	EP305L2	--	132M-4	OK	PAGE 110
29.0	2325	1.82	48.3	13.0	EP306L2	--	132M-4	OK	PAGE 120
29.1	2240	0.94	48.1	7.5	EP303L3	--	132M-4	OK	PAGE 100
29.1	2240	1.41	48.1	7.5	EP305L3	--	132M-4	OK	PAGE 110
29.6	2204	2.34	47.4	20.0	--	EP309R3	132M-4	OK	PAGE 140
29.6	2204	2.93	47.4	20.0	--	EP307R3	132M-4	OK	PAGE 130
30.7	2126	2.46	45.7	7.5	EP306L3	--	132M-4	OK	PAGE 120
32.6	1999	2.70	43.0	14.0	--	EP306R3	132M-4	OK	PAGE 120
33.9	1925	2.58	41.3	20.0	--	EP309R3	132M-4	OK	PAGE 140
33.9	1925	3.28	41.3	20.0	--	EP307R3	132M-4	OK	PAGE 130
34.9	1929	0.91	40.1	9.0	EP303L2	--	132M-4	OK	PAGE 100
34.9	1929	1.70	40.1	9.0	EP305L2	--	132M-4	OK	PAGE 110
35.5	1897	2.50	39.4	13.0	EP306L2	--	132M-4	OK	PAGE 120
36.6	1781	1.45	38.3	14.0	--	EP303R3	132M-4	OK	PAGE 100
36.6	1781	1.64	38.3	14.0	--	EP305R3	132M-4	OK	PAGE 110
38.8	1680	3.16	36.1	14.0	--	EP306R3	132M-4	OK	PAGE 120
43.4	1550	2.72	32.2	13.0	EP306L2	--	132M-4	OK	PAGE 120
43.5	1500	2.93	32.2	20.0	--	EP309R3	132M-4	OK	PAGE 140
43.6	1546	1.13	32.1	9.0	EP303L2	--	132M-4	OK	PAGE 100
43.6	1546	2.04	32.1	9.0	EP305L2	--	132M-4	OK	PAGE 110
43.8	1539	0.85	32.0	7.5	EP301L2	--	132M-4	OK	PAGE 90
45.4	1436	0.90	30.8	12.0	--	EP301R3	132M-4	OK	PAGE 90
46.7	1443	1.30	30.0	9.0	EP303L2	--	132M-4	OK	PAGE 100
46.7	1443	2.21	30.0	9.0	EP305L2	--	132M-4	OK	PAGE 110
48.0	1357	1.76	29.1	14.0	--	EP305R3	132M-4	OK	PAGE 110
48.0	1357	1.79	29.1	14.0	--	EP303R3	132M-4	OK	PAGE 100
48.4	1391	2.95	28.9	13.0	EP306L2	--	132M-4	OK	PAGE 120
48.5	1387	1.36	28.8	9.0	EP303L2	--	132M-4	OK	PAGE 100
48.5	1387	2.27	28.8	9.0	EP305L2	--	132M-4	OK	PAGE 110
54.6	1233	0.93	25.6	7.5	EP301L2	--	132M-4	OK	PAGE 90

EP300 series gear motor

P1=7.5KW n1=1400 min⁻¹

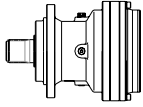
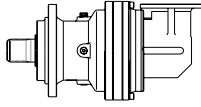
n ₂ (min ⁻¹)	M ₂ (N.m)	S	I 1:	P _t (KW)			IEC Motor type	Check Thermal	Dimension
								Power Pt >= P1	Page Number
55.0	1184	1.52	25.4	14.0	--	EP305R3	132M-4	OK	PAGE 110
55.0	1184	1.68	25.4	14.0	--	EP303R3	132M-4	OK	PAGE 100
55.6	1212	1.48	25.2	9.0	EP303L2	--	132M-4	OK	PAGE 100
55.6	1212	2.50	25.2	9.0	EP305L2	--	132M-4	OK	PAGE 110
56.7	1188	3.40	24.7	13.0	EP306L2	--	132M-4	OK	PAGE 120
57.8	1165	1.48	24.2	9.0	EP303L2	--	132M-4	OK	PAGE 100
57.8	1165	2.50	24.2	9.0	EP305L2	--	132M-4	OK	PAGE 110
59.6	1093	0.94	23.5	12.0	--	EP301R3	132M-4	OK	PAGE 90
70.9	950	1.13	19.8	7.5	EP301L2	--	132M-4	OK	PAGE 90
75.0	898	1.93	18.7	9.0	EP303L2	--	132M-4	OK	PAGE 100
75.0	898	2.84	18.7	9.0	EP305L2	--	132M-4	OK	PAGE 110
80.1	840	1.62	17.5	18.0	--	EP303R2	132M-4	OK	PAGE 100
80.1	840	1.62	17.5	18.0	--	EP305R2	132M-4	OK	PAGE 110
93.1	723	0.85	15.0	7.5	EP300L2	--	132M-4	OK	PAGE 80
93.1	723	1.36	15.0	7.5	EP301L2	--	132M-4	OK	PAGE 90
94.9	710	1.25	14.8	12.0	--	EP301R2	132M-4	OK	PAGE 90
98.1	687	2.14	14.3	18.0	--	EP303R2	132M-4	OK	PAGE 100
98.1	687	2.14	14.3	18.0	--	EP305R2	132M-4	OK	PAGE 110
98.5	684	2.50	14.2	9.0	EP303L2	--	132M-4	OK	PAGE 100
98.5	684	3.40	14.2	9.0	EP305L2	--	132M-4	OK	PAGE 110
109	616	3.06	12.8	18.0	--	EP303R2	132M-4	OK	PAGE 100
109	616	3.06	12.8	18.0	--	EP305R2	132M-4	OK	PAGE 110
113	597	2.84	12.4	9.0	EP303L2	--	132M-4	OK	PAGE 100
113	597	3.40	12.4	9.0	EP305L2	--	132M-4	OK	PAGE 110
118	569	1.59	11.8	12.0	--	EP301R2	132M-4	OK	PAGE 90
122	551	1.02	11.5	7.5	EP300L2	--	132M-4	OK	PAGE 80
122	551	1.70	11.5	7.5	EP301L2	--	132M-4	OK	PAGE 90
154	438	1.70	9.1	12.0	--	EP300R2	132M-4	OK	PAGE 80
154	438	1.70	9.1	12.0	--	EP301R2	132M-4	OK	PAGE 90
194	357	1.21	7.2	7.5	EP300L1	--	132M-4	OK	PAGE 80
194	357	1.21	7.2	7.5	EP300L1	--	132M-4	OK	PAGE 80
194	357	1.98	7.2	7.5	EP301L1	--	132M-4	OK	PAGE 90
202	334	1.70	6.9	12.0	--	EP300R2	132M-4	OK	PAGE 80
202	334	1.70	6.9	12.0	--	EP301R2	132M-4	OK	PAGE 90
243	286	1.65	5.8	7.5	EP300L1	--	132M-4	OK	PAGE 80
243	286	3.08	5.8	7.5	EP301L1	--	132M-4	OK	PAGE 90
315	221	2.20	4.4	7.5	EP300L1	--	132M-4	OK	PAGE 80
315	221	3.30	4.4	7.5	EP301L1	--	132M-4	OK	PAGE 90
414	168	2.20	3.4	7.5	EP300L1	--	132M-4	OK	PAGE 80

EP300 series gear motor

P1=11KW n1=1400 min⁻¹

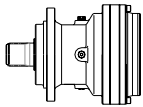
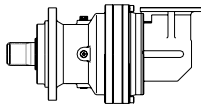
n ₂ (min ⁻¹)	M ₂ (N.m)	S	I 1:	P _t (KW)			IEC Motor type	Check Thermal	Dimension
								Power Pt >= P1	Page Number
1.0	91752	1.28	1390	18.0	EP316L4	--	160M-4	OK	PAGE 190
1.1	81141	0.87	1229	18.0	EP315L4	--	160M-4	OK	PAGE 180

EP300 series gear motor

P1=11KW n1=1400 min⁻¹

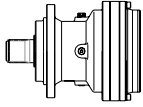
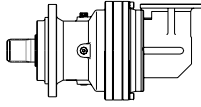
n ₂ (min ⁻¹)	M ₂ (N.m)	S	I 1:	P _t (KW)			IEC Motor type	Check Thermal	Dimension
								Power Pt >= P1	Page Number
1.2	77310	1.49	1171	18.0	EP316L4	--	160M-4	OK	PAGE 190
1.4	68369	1.16	1036	18.0	EP315L4	--	160M-4	OK	PAGE 180
1.4	64793	1.82	981	18.0	EP316L4	--	160M-4	OK	PAGE 190
1.6	57300	1.45	868	18.0	EP315L4	--	160M-4	OK	PAGE 180
1.7	54594	2.07	827	18.0	EP316L4	--	160M-4	OK	PAGE 190
1.8	50966	1.32	772	40.0	--	EP315R4	160M-4	OK	PAGE 180
1.8	50944	2.31	772	45.0	--	EP316R4	160M-4	OK	PAGE 190
2.1	44611	2.48	676	18.0	EP316L4	--	160M-4	OK	PAGE 190
2.1	43678	0.91	662	22.0	--	EP313R4	160M-4	OK	PAGE 170
2.2	42948	1.03	650	11.0	EP313L4	--	160M-4	OK	PAGE 170
2.2	42944	1.74	650	40.0	--	EP315R4	160M-4	OK	PAGE 180
2.2	42925	2.73	650	45.0	--	EP316R4	160M-4	OK	PAGE 190
2.2	42020	1.90	636	18.0	EP315L4	--	160M-4	OK	PAGE 180
2.3	40036	2.81	606	18.0	EP316L4	--	160M-4	OK	PAGE 190
2.5	36956	0.93	560	11.0	EP311L4	--	160M-4	OK	PAGE 160
2.5	36836	1.24	558	22.0	--	EP313R4	160M-4	OK	PAGE 170
2.6	36076	1.24	546	11.0	EP313L4	--	160M-4	OK	PAGE 170
2.6	35975	3.31	545	45.0	--	EP316R4	160M-4	OK	PAGE 190
2.6	35886	2.15	544	18.0	EP315L4	--	160M-4	OK	PAGE 180
2.6	35039	1.90	531	40.0	--	EP315R4	160M-4	OK	PAGE 180
2.8	33554	3.31	508	18.0	EP316L4	--	160M-4	OK	PAGE 190
3.0	31038	1.45	470	22.0	--	EP313R4	160M-4	OK	PAGE 170
3.0	30496	2.15	462	40.0	--	EP315R4	160M-4	OK	PAGE 180
3.0	30434	2.48	461	18.0	EP315L4	--	160M-4	OK	PAGE 180
3.1	30188	1.10	457	22.0	--	EP311R4	160M-4	OK	PAGE 160
3.2	28797	1.16	436	11.0	EP311L4	--	160M-4	OK	PAGE 160
3.3	28157	1.82	426	11.0	EP313L4	--	160M-4	OK	PAGE 170
3.6	25695	2.64	389	40.0	--	EP315R4	160M-4	OK	PAGE 180
3.6	25565	2.89	387	18.0	EP315L4	--	160M-4	OK	PAGE 180
3.6	25436	1.28	385	22.0	--	EP311R4	160M-4	OK	PAGE 160
3.6	25362	1.74	384	22.0	--	EP313R4	160M-4	OK	PAGE 170
3.8	24472	0.84	371	14.0	--	EP310R4	160M-4	OK	PAGE 150
4.1	22761	1.90	345	22.0	--	EP313R4	160M-4	OK	PAGE 170
4.2	22184	1.49	336	11.0	EP311L4	--	160M-4	OK	PAGE 160
4.3	21691	0.99	329	11.0	EP310L4	--	160M-4	OK	PAGE 150
4.3	21691	2.31	329	11.0	EP313L4	--	160M-4	OK	PAGE 170
4.3	21535	3.55	326	40.0	--	EP315R4	160M-4	OK	PAGE 180
4.4	20900	0.95	317	14.0	--	EP310R4	160M-4	OK	PAGE 150
4.4	20785	1.54	315	22.0	--	EP311R4	160M-4	OK	PAGE 160
4.6	20567	2.98	301	30.0	EP315L3	--	160M-4	OK	PAGE 180
4.8	19076	2.23	289	22.0	--	EP313R4	160M-4	OK	PAGE 170
4.9	18928	1.74	287	11.0	EP311L4	--	160M-4	OK	PAGE 160
5.0	18653	1.69	283	22.0	--	EP311R4	160M-4	OK	PAGE 160
5.0	18477	2.48	280	11.0	EP313L4	--	160M-4	OK	PAGE 170
5.2	18364	0.92	269	18.0	EP310L3	--	160M-4	OK	PAGE 150
5.2	17724	1.07	268	14.0	--	EP310R4	160M-4	OK	PAGE 150
5.3	18072	1.28	265	18.0	EP311L3	--	160M-4	OK	PAGE 160
5.4	17626	2.48	258	18.0	EP313L3	--	160M-4	OK	PAGE 170
5.5	16894	1.90	256	11.0	EP311L4	--	160M-4	OK	PAGE 160
5.6	16519	2.48	250	11.0	EP313L4	--	160M-4	OK	PAGE 170
5.8	16024	2.56	243	22.0	--	EP313R4	160M-4	OK	PAGE 170

EP300 series gear motor

P1=11KW n1=1400 min⁻¹

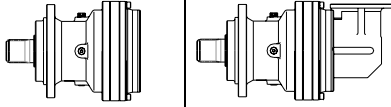
n ₂ (min ⁻¹)	M ₂ (N.m)	S	I 1:	P _t (KW)			IEC Motor type	Check Thermal Power Pt >= P1	Dimension Page Number
5.9	15633	1.90	237	22.0	--	EP311R4	160M-4	OK	PAGE 160
6.2	14889	1.24	226	14.0	--	EP310R4	160M-4	OK	PAGE 150
6.3	15228	1.76	223	18.0	EP311L3	--	160M-4	OK	PAGE 160
6.4	15006	1.12	220	18.0	EP310L3	--	160M-4	OK	PAGE 150
6.4	14430	0.99	219	14.0	--	EP309R4	160M-4	OK	PAGE 140
6.4	14865	2.88	218	18.0	EP313L3	--	160M-4	OK	PAGE 170
6.6	13989	2.89	212	22.0	--	EP313R4	160M-4	OK	PAGE 170
6.6	14379	1.04	211	11.0	EP309L3	--	160M-4	OK	PAGE 140
7.0	13132	2.15	199	22.0	--	EP311R4	160M-4	OK	PAGE 160
7.1	13467	1.52	197	18.0	EP310L3	--	160M-4	OK	PAGE 150
7.4	12506	1.40	189	14.0	--	EP310R4	160M-4	OK	PAGE 150
7.4	12506	2.89	189	22.0	--	EP313R4	160M-4	OK	PAGE 170
7.4	12831	2.00	188	18.0	EP311L3	--	160M-4	OK	PAGE 160
7.6	12525	3.20	183	18.0	EP313L3	--	160M-4	OK	PAGE 170
8.1	11464	2.40	174	22.0	--	EP311R4	160M-4	OK	PAGE 160
8.3	11521	1.28	169	11.0	EP309L3	--	160M-4	OK	PAGE 140
8.3	11117	1.24	168	14.0	--	EP309R4	160M-4	OK	PAGE 140
8.5	10918	2.89	165	22.0	--	EP313R4	160M-4	OK	PAGE 170
8.7	11004	1.76	161	18.0	EP310L3	--	160M-4	OK	PAGE 150
9.0	10232	2.64	155	22.0	--	EP311R4	160M-4	OK	PAGE 160
9.1	10485	2.24	154	18.0	EP311L3	--	160M-4	OK	PAGE 160
9.2	10340	0.94	151	11.0	EP307L3	--	160M-4	OK	PAGE 130
9.2	10340	1.36	151	11.0	EP309L3	--	160M-4	OK	PAGE 140
9.3	10235	3.60	150	18.0	EP313L3	--	160M-4	OK	PAGE 170
9.6	9588	1.74	145	14.0	--	EP310R4	160M-4	OK	PAGE 150
9.7	9876	1.92	145	18.0	EP310L3	--	160M-4	OK	PAGE 150
9.8	9787	3.20	143	40.0	--	EP313R3	160M-4	OK	PAGE 170
10.2	9409	2.40	138	18.0	EP311L3	--	160M-4	OK	PAGE 160
10.9	8508	2.89	129	22.0	--	EP313R4	160M-4	OK	PAGE 170
10.9	8466	1.28	128	14.0	--	EP309R4	160M-4	OK	PAGE 140
11.0	8666	1.12	127	11.0	EP307L3	--	160M-4	OK	PAGE 130
11.0	8666	1.60	127	11.0	EP309L3	--	160M-4	OK	PAGE 140
11.3	8459	1.60	124	20.0	--	EP310R3	160M-4	OK	PAGE 150
11.3	8455	2.80	124	40.0	--	EP311R3	160M-4	OK	PAGE 160
11.3	8434	2.24	124	18.0	EP310L3	--	160M-4	OK	PAGE 150
11.5	8063	0.93	122	12.0	--	EP306R4	160M-4	OK	PAGE 120
11.6	8254	3.60	121	40.0	--	EP313R3	160M-4	OK	PAGE 170
12.1	7886	2.80	116	18.0	EP311L3	--	160M-4	OK	PAGE 160
12.5	7391	0.99	112	14.0	--	EP307R4	160M-4	OK	PAGE 130
12.9	7433	0.96	109	20.0	--	EP307R3	160M-4	OK	PAGE 130
12.9	7433	1.28	109	20.0	--	EP309R3	160M-4	OK	PAGE 140
13.1	7279	1.28	107	11.0	EP307L3	--	160M-4	OK	PAGE 130
13.1	7279	1.84	107	11.0	EP309L3	--	160M-4	OK	PAGE 140
13.4	7153	2.56	105	18.0	EP310L3	--	160M-4	OK	PAGE 150
13.4	7124	3.20	104	40.0	--	EP311R3	160M-4	OK	PAGE 160
13.8	6933	0.88	102	7.5	EP306L3	--	160M-4	NO !	PAGE 120
13.8	6902	1.92	101	20.0	--	EP310R3	160M-4	OK	PAGE 150
14.4	6624	3.04	97.0	18.0	EP311L3	--	160M-4	OK	PAGE 160
15.0	6181	1.16	93.6	12.0	--	EP306R4	160M-4	OK	PAGE 120
15.3	6263	1.20	91.7	20.0	--	EP307R3	160M-4	OK	PAGE 130
15.3	6263	1.44	91.7	20.0	--	EP309R3	160M-4	OK	PAGE 140

EP300 series gear motor

P1=11KW n1=1400 min⁻¹

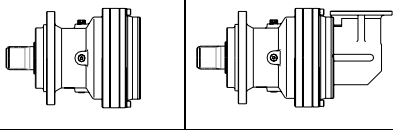
n ₂ (min ⁻¹)	M ₂ (N.m)	S	I 1:	P _t (KW)			IEC Motor type	Check Thermal Power Pt >= P1	Dimension Page Number
15.9	6008	2.96	88.0	18.0	EP310L3	--	160M-4	OK	PAGE 150
16.2	5894	2.16	86.3	20.0	--	EP310R3	160M-4	OK	PAGE 150
16.5	5783	3.36	84.7	18.0	EP311L3	--	160M-4	OK	PAGE 160
17.0	5608	1.60	82.1	11.0	EP307L3	--	160M-4	OK	PAGE 130
17.0	5608	2.24	82.1	11.0	EP309L3	--	160M-4	OK	PAGE 140
17.3	5521	1.04	80.9	14.0	--	EP306R3	160M-4	OK	PAGE 120
17.9	5341	1.04	78.2	7.5	EP306L3	--	160M-4	NO !	PAGE 120
18.7	5117	1.44	75.0	20.0	--	EP307R3	160M-4	OK	PAGE 130
18.7	5117	1.60	75.0	20.0	--	EP309R3	160M-4	OK	PAGE 140
18.9	5061	2.64	74.1	20.0	--	EP310R3	160M-4	OK	PAGE 150
18.9	5047	3.36	73.9	18.0	EP310L3	--	160M-4	OK	PAGE 150
20.8	4593	1.60	67.3	20.0	--	EP307R3	160M-4	OK	PAGE 130
20.8	4593	1.76	67.3	20.0	--	EP309R3	160M-4	OK	PAGE 140
21.2	4512	1.20	66.1	14.0	--	EP306R3	160M-4	OK	PAGE 120
22.1	4322	2.96	63.3	20.0	--	EP310R3	160M-4	OK	PAGE 150
22.4	4270	2.00	62.5	11.0	EP307L3	--	160M-4	OK	PAGE 130
22.4	4270	2.64	62.5	11.0	EP309L3	--	160M-4	OK	PAGE 140
23.5	4067	1.32	59.6	7.5	EP306L3	--	160M-4	NO !	PAGE 120
23.6	4049	1.32	59.3	14.0	--	EP306R3	160M-4	OK	PAGE 120
24.8	3849	1.60	56.4	20.0	--	EP309R3	160M-4	OK	PAGE 140
24.8	3849	1.76	56.4	20.0	--	EP307R3	160M-4	OK	PAGE 130
25.6	3728	2.24	54.6	11.0	EP307L3	--	160M-4	OK	PAGE 130
25.6	3728	2.88	54.6	11.0	EP309L3	--	160M-4	OK	PAGE 140
26.1	3666	3.28	53.7	20.0	--	EP310R3	160M-4	OK	PAGE 150
27.1	3527	0.96	51.7	14.0	--	EP305R3	160M-4	OK	PAGE 110
27.6	3458	1.52	50.6	14.0	--	EP306R3	160M-4	OK	PAGE 120
28.2	3391	0.96	49.7	14.0	--	EP305R3	160M-4	OK	PAGE 110
29.0	3410	1.24	48.3	13.0	EP306L2	--	160M-4	OK	PAGE 120
29.1	3285	0.96	48.1	7.5	EP305L3	--	160M-4	NO !	PAGE 110
29.6	3233	1.60	47.4	20.0	--	EP309R3	160M-4	OK	PAGE 140
29.6	3233	2.00	47.4	20.0	--	EP307R3	160M-4	OK	PAGE 130
30.7	3118	1.68	45.7	7.5	EP306L3	--	160M-4	NO !	PAGE 120
31.0	3079	3.60	45.1	20.0	--	EP310R3	160M-4	OK	PAGE 150
32.6	2933	1.84	43.0	14.0	--	EP306R3	160M-4	OK	PAGE 120
32.9	2905	3.36	42.5	11.0	EP309L3	--	160M-4	OK	PAGE 140
33.0	2996	2.48	42.5	18.0	EP307L2	--	160M-4	OK	PAGE 130
33.0	2996	3.25	42.5	18.0	EP309L2	--	160M-4	OK	PAGE 140
33.9	2823	1.76	41.3	20.0	--	EP309R3	160M-4	OK	PAGE 140
34.9	2829	1.16	40.1	9.0	EP305L2	--	160M-4	NO !	PAGE 110
35.3	2704	3.60	39.6	20.0	--	EP310R3	160M-4	OK	PAGE 150
35.5	2782	1.70	39.4	13.0	EP306L2	--	160M-4	OK	PAGE 120
36.6	2613	0.99	38.3	14.0	--	EP303R3	160M-4	OK	PAGE 100
36.6	2613	1.12	38.3	14.0	--	EP305R3	160M-4	OK	PAGE 110
38.8	2463	2.16	36.1	14.0	--	EP306R3	160M-4	OK	PAGE 120
39.1	2525	2.86	35.8	18.0	EP307L2	--	160M-4	OK	PAGE 130
43.4	2273	1.86	32.2	13.0	EP306L2	--	160M-4	OK	PAGE 120
43.5	2199	2.00	32.2	20.0	--	EP309R3	160M-4	OK	PAGE 140
43.5	2199	2.40	32.2	20.0	--	EP307R3	160M-4	OK	PAGE 130
43.6	2267	1.39	32.1	9.0	EP305L2	--	160M-4	NO !	PAGE 110
46.7	2116	0.89	30.0	9.0	EP303L2	--	160M-4	NO !	PAGE 100
46.7	2116	1.51	30.0	9.0	EP305L2	--	160M-4	NO !	PAGE 110

EP300 series gear motor

P1=11KW n1=1400 min⁻¹

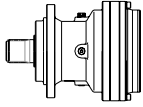
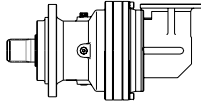
n₂ (min ⁻¹)	M₂ (N.m)	S	I 1:	P_t (KW)			IEC Motor type	Check Thermal Power Pt >= P1	Dimension Page Number
47.9	2063	3.48	29.3	18.0	EP307L2	--	160M-4	OK	PAGE 130
48.0	1990	1.20	29.1	14.0	--	EP305R3	160M-4	OK	PAGE 110
48.0	1990	1.22	29.1	14.0	--	EP303R3	160M-4	OK	PAGE 100
48.4	2040	2.01	28.9	13.0	EP306L2	--	160M-4	OK	PAGE 120
48.5	2034	0.93	28.8	9.0	EP303L2	--	160M-4	NO !	PAGE 100
48.5	2034	1.55	28.8	9.0	EP305L2	--	160M-4	NO !	PAGE 110
50.6	1889	2.80	27.7	14.0	--	EP306R3	160M-4	OK	PAGE 120
55.0	1737	1.04	25.4	14.0	--	EP305R3	160M-4	OK	PAGE 110
55.0	1737	1.14	25.4	14.0	--	EP303R3	160M-4	OK	PAGE 100
55.6	1777	1.01	25.2	9.0	EP303L2	--	160M-4	NO !	PAGE 100
55.6	1777	1.70	25.2	9.0	EP305L2	--	160M-4	NO !	PAGE 110
56.7	1742	2.32	24.7	13.0	EP306L2	--	160M-4	OK	PAGE 120
57.8	1709	1.01	24.2	9.0	EP303L2	--	160M-4	NO !	PAGE 100
57.8	1709	1.70	24.2	9.0	EP305L2	--	160M-4	NO !	PAGE 110
59.4	1664	3.25	23.6	35.0	--	EP307R2	160M-4	OK	PAGE 130
59.4	1664	3.48	23.6	35.0	--	EP309R2	160M-4	OK	PAGE 140
66.8	1478	3.09	21.0	13.0	EP306L2	--	160M-4	OK	PAGE 120
70.4	1402	3.48	19.9	35.0	--	EP309R2	160M-4	OK	PAGE 140
75.0	1316	1.32	18.7	9.0	EP303L2	--	160M-4	NO !	PAGE 100
75.0	1316	1.93	18.7	9.0	EP305L2	--	160M-4	NO !	PAGE 110
77.0	1281	2.71	18.2	18.0	--	EP306R2	160M-4	OK	PAGE 120
79.5	1241	3.09	17.6	13.0	EP306L2	--	160M-4	OK	PAGE 120
80.1	1232	1.11	17.5	18.0	--	EP303R2	160M-4	OK	PAGE 100
80.1	1232	1.11	17.5	18.0	--	EP305R2	160M-4	OK	PAGE 110
93.1	1061	0.93	15.0	7.5	EP301L2	--	160M-4	NO !	PAGE 90
94.4	1046	2.71	14.8	18.0	--	EP306R2	160M-4	OK	PAGE 120
94.9	1041	0.85	14.8	12.0	--	EP301R2	160M-4	OK	PAGE 90
98.1	1007	1.46	14.3	18.0	--	EP303R2	160M-4	OK	PAGE 100
98.1	1007	1.46	14.3	18.0	--	EP305R2	160M-4	OK	PAGE 110
98.5	1003	1.70	14.2	9.0	EP303L2	--	160M-4	NO !	PAGE 100
98.5	1003	2.32	14.2	9.0	EP305L2	--	160M-4	NO !	PAGE 110
104	952	3.09	13.5	13.0	EP306L2	--	160M-4	OK	PAGE 120
109	904	2.09	12.8	18.0	--	EP303R2	160M-4	OK	PAGE 100
109	904	2.09	12.8	18.0	--	EP305R2	160M-4	OK	PAGE 110
111	893	2.71	12.7	18.0	--	EP306R2	160M-4	OK	PAGE 120
113	875	1.93	12.4	9.0	EP303L2	--	160M-4	NO !	PAGE 100
113	875	2.32	12.4	9.0	EP305L2	--	160M-4	NO !	PAGE 110
118	834	1.08	11.8	12.0	--	EP301R2	160M-4	OK	PAGE 90
122	808	1.16	11.5	7.5	EP301L2	--	160M-4	NO !	PAGE 90
130	759	2.71	10.8	18.0	--	EP303R2	160M-4	OK	PAGE 100
130	759	2.71	10.8	18.0	--	EP305R2	160M-4	OK	PAGE 110
130	757	2.71	10.7	18.0	--	EP306R2	160M-4	OK	PAGE 120
148	665	2.71	9.4	18.0	--	EP306R2	160M-4	OK	PAGE 120
149	663	2.71	9.4	18.0	--	EP303R2	160M-4	OK	PAGE 100
149	663	2.71	9.4	18.0	--	EP305R2	160M-4	OK	PAGE 110
154	643	1.16	9.1	12.0	--	EP301R2	160M-4	OK	PAGE 90
194	524	1.35	7.2	7.5	EP301L1	--	160M-4	NO !	PAGE 90
202	489	1.16	6.9	12.0	--	EP301R2	160M-4	OK	PAGE 90
205	496	2.70	6.8	11.0	EP303L1	--	160M-4	OK	PAGE 100
243	420	1.12	5.8	7.5	EP300L1	--	160M-4	NO !	PAGE 80
243	420	2.10	5.8	7.5	EP301L1	--	160M-4	NO !	PAGE 90

EP300 series gear motor

P1=11KW n1=1400 min⁻¹

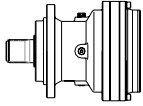
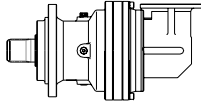
n₂ (min ⁻¹)	M₂ (N.m)	S	I 1:	P_t (KW)			IEC Motor type	Check Thermal Power Pt >= P1	Dimension Page Number
251	405	3.00	5.6	11.0	EP303L1	--	160M-4	OK	PAGE 100
280	364	3.00	5.0	11.0	EP303L1	--	160M-4	OK	PAGE 100
280	364	3.00	5.0	11.0	EP303L1	--	160M-4	OK	PAGE 100
315	323	1.50	4.4	7.5	EP300L1	--	160M-4	NO !	PAGE 80
315	323	2.25	4.4	7.5	EP301L1	--	160M-4	NO !	PAGE 90
333	306	3.00	4.2	11.0	EP303L1	--	160M-4	OK	PAGE 100
382	267	3.00	3.7	11.0	EP303L1	--	160M-4	OK	PAGE 100
414	246	1.50	3.4	7.5	EP300L1	--	160M-4	NO !	PAGE 80
414	246	2.25	3.4	7.5	EP301L1	--	160M-4	NO !	PAGE 90

EP300 series gear motor

P1=15KW n1=1400 min⁻¹

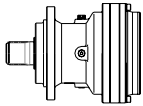
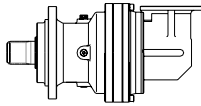
n₂ (min ⁻¹)	M₂ (N.m)	S	I 1:	P_t (KW)			IEC Motor type	Check Thermal Power Pt >= P1	Dimension Page Number
1.0	125117	0.94	1390	18.0	EP316L4	--	160L-4	OK	PAGE 190
1.2	105422	1.09	1171	18.0	EP316L4	--	160L-4	OK	PAGE 190
1.4	93231	0.85	1036	18.0	EP315L4	--	160L-4	OK	PAGE 180
1.4	88354	1.33	981	18.0	EP316L4	--	160L-4	OK	PAGE 190
1.6	78136	1.06	868	18.0	EP315L4	--	160L-4	OK	PAGE 180
1.7	74446	1.52	827	18.0	EP316L4	--	160L-4	OK	PAGE 190
1.8	69499	0.97	772	40.0	--	EP315R4	160L-4	OK	PAGE 180
1.8	69470	1.70	772	45.0	--	EP316R4	160L-4	OK	PAGE 190
2.1	60833	1.82	676	18.0	EP316L4	--	160L-4	OK	PAGE 190
2.2	58560	1.27	650	40.0	--	EP315R4	160L-4	OK	PAGE 180
2.2	58534	2.00	650	45.0	--	EP316R4	160L-4	OK	PAGE 190
2.2	57300	1.39	636	18.0	EP315L4	--	160L-4	OK	PAGE 180
2.3	54594	2.06	606	18.0	EP316L4	--	160L-4	OK	PAGE 190
2.5	50231	0.91	558	22.0	--	EP313R4	160L-4	OK	PAGE 170
2.6	49195	0.91	546	11.0	EP313L4	--	160L-4	NO !	PAGE 170
2.6	49057	2.42	545	45.0	--	EP316R4	160L-4	OK	PAGE 190
2.6	48936	1.58	544	18.0	EP315L4	--	160L-4	OK	PAGE 180
2.6	47781	1.39	531	40.0	--	EP315R4	160L-4	OK	PAGE 180
2.8	45755	2.42	508	18.0	EP316L4	--	160L-4	OK	PAGE 190
3.0	42324	1.06	470	22.0	--	EP313R4	160L-4	OK	PAGE 170
3.0	41585	1.58	462	40.0	--	EP315R4	160L-4	OK	PAGE 180
3.0	41501	1.82	461	18.0	EP315L4	--	160L-4	OK	PAGE 180
3.0	41335	2.73	459	45.0	--	EP316R4	160L-4	OK	PAGE 190
3.2	39268	0.85	436	11.0	EP311L4	--	160L-4	NO !	PAGE 160
3.3	38434	2.85	427	18.0	EP316L4	--	160L-4	OK	PAGE 190
3.3	38396	1.33	426	11.0	EP313L4	--	160L-4	NO !	PAGE 170
3.5	35653	3.09	396	18.0	EP316L4	--	160L-4	OK	PAGE 190
3.6	35039	1.94	389	40.0	--	EP315R4	160L-4	OK	PAGE 180
3.6	34861	2.12	387	18.0	EP315L4	--	160L-4	OK	PAGE 180
3.6	34685	0.94	385	22.0	--	EP311R4	160L-4	OK	PAGE 160
3.6	34643	3.15	385	45.0	--	EP316R4	160L-4	OK	PAGE 190
3.6	34585	1.27	384	22.0	--	EP313R4	160L-4	OK	PAGE 170

EP300 series gear motor

P1=15KW n1=1400 min⁻¹

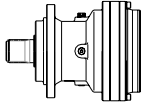
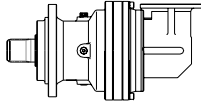
n ₂ (min ⁻¹)	M ₂ (N.m)	S	I 1:	P _t (KW)			IEC Motor type	Check Thermal	Dimension
								Power Pt >= P1	Page Number
4.1	31038	1.39	345	22.0	--	EP313R4	160L-4	OK	PAGE 170
4.2	30371	3.03	337	18.0	EP315L4	--	160L-4	OK	PAGE 180
4.2	30251	1.09	336	11.0	EP311L4	--	160L-4	NO !	PAGE 160
4.3	29579	1.70	329	11.0	EP313L4	--	160L-4	NO !	PAGE 170
4.3	29366	2.61	326	40.0	--	EP315R4	160L-4	OK	PAGE 180
4.4	28343	1.13	315	22.0	--	EP311R4	160L-4	OK	PAGE 160
4.6	28046	2.19	301	30.0	EP315L3	--	160L-4	OK	PAGE 180
4.8	26013	1.64	289	22.0	--	EP313R4	160L-4	OK	PAGE 170
4.9	25811	1.27	287	11.0	EP311L4	--	160L-4	NO !	PAGE 160
5.0	25436	1.24	283	22.0	--	EP311R4	160L-4	OK	PAGE 160
5.0	25196	1.82	280	11.0	EP313L4	--	160L-4	NO !	PAGE 170
5.0	25080	3.03	279	40.0	--	EP315R4	160L-4	OK	PAGE 180
5.3	24644	0.94	265	18.0	EP311L3	--	160L-4	OK	PAGE 160
5.4	24036	1.82	258	18.0	EP313L3	--	160L-4	OK	PAGE 170
5.5	23037	1.39	256	11.0	EP311L4	--	160L-4	NO !	PAGE 160
5.5	23632	2.87	254	30.0	EP315L3	--	160L-4	OK	PAGE 180
5.6	22526	1.82	250	11.0	EP313L4	--	160L-4	NO !	PAGE 170
5.8	21851	1.88	243	22.0	--	EP313R4	160L-4	OK	PAGE 170
5.9	21318	1.39	237	22.0	--	EP311R4	160L-4	OK	PAGE 160
6.2	20303	0.91	226	14.0	--	EP310R4	160L-4	NO !	PAGE 150
6.3	20765	1.29	223	18.0	EP311L3	--	160L-4	OK	PAGE 160
6.4	20271	2.11	218	18.0	EP313L3	--	160L-4	OK	PAGE 170
6.6	19076	2.12	212	22.0	--	EP313R4	160L-4	OK	PAGE 170
6.9	18976	3.42	204	30.0	EP316L3	--	160L-4	OK	PAGE 190
7.0	17907	1.58	199	22.0	--	EP311R4	160L-4	OK	PAGE 160
7.1	18364	1.11	197	18.0	EP310L3	--	160L-4	OK	PAGE 150
7.4	17054	1.03	189	14.0	--	EP310R4	160L-4	NO !	PAGE 150
7.4	17054	2.12	189	22.0	--	EP313R4	160L-4	OK	PAGE 170
7.4	17496	1.47	188	18.0	EP311L3	--	160L-4	OK	PAGE 160
7.6	17080	2.34	183	18.0	EP313L3	--	160L-4	OK	PAGE 170
8.1	15633	1.76	174	22.0	--	EP311R4	160L-4	OK	PAGE 160
8.5	14889	2.12	165	22.0	--	EP313R4	160L-4	OK	PAGE 170
8.7	15006	1.29	161	18.0	EP310L3	--	160L-4	OK	PAGE 150
9.0	13953	1.94	155	22.0	--	EP311R4	160L-4	OK	PAGE 160
9.1	14297	1.64	154	18.0	EP311L3	--	160L-4	OK	PAGE 160
9.2	14100	1.00	151	11.0	EP309L3	--	160L-4	NO !	PAGE 140
9.3	13957	2.64	150	18.0	EP313L3	--	160L-4	OK	PAGE 170
9.6	13075	1.27	145	14.0	--	EP310R4	160L-4	NO !	PAGE 150
9.7	13467	1.41	145	18.0	EP310L3	--	160L-4	OK	PAGE 150
9.8	13346	2.34	143	40.0	--	EP313R3	160L-4	OK	PAGE 170
10.2	12831	1.76	138	18.0	EP311L3	--	160L-4	OK	PAGE 160
10.4	12525	2.93	135	18.0	EP313L3	--	160L-4	OK	PAGE 170
10.9	11601	2.12	129	22.0	--	EP313R4	160L-4	OK	PAGE 170
10.9	11544	0.94	128	14.0	--	EP309R4	160L-4	NO !	PAGE 140
11.0	11817	1.17	127	11.0	EP309L3	--	160L-4	NO !	PAGE 140
11.3	11534	1.17	124	20.0	--	EP310R3	160L-4	OK	PAGE 150
11.3	11530	2.05	124	40.0	--	EP311R3	160L-4	OK	PAGE 160
11.3	11501	1.64	124	18.0	EP310L3	--	160L-4	OK	PAGE 150
11.6	11255	2.64	121	40.0	--	EP313R3	160L-4	OK	PAGE 170
12.1	10753	2.05	116	18.0	EP311L3	--	160L-4	OK	PAGE 160
12.4	10497	3.22	113	18.0	EP313L3	--	160L-4	OK	PAGE 170

EP300 series gear motor

P1=15KW n1=1400 min⁻¹

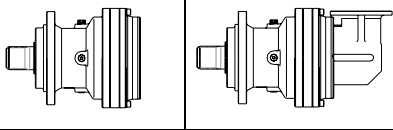
n ₂ (min ⁻¹)	M ₂ (N.m)	S	I 1:	P _t (KW)			IEC Motor type	Check Thermal Power Pt >= P1	Dimension Page Number
12.9	10135	0.94	109	20.0	--	EP309R3	160L-4	OK	PAGE 140
13.1	9926	0.94	107	11.0	EP307L3	--	160L-4	NO !	PAGE 130
13.1	9926	1.35	107	11.0	EP309L3	--	160L-4	NO !	PAGE 140
13.4	9754	1.88	105	18.0	EP310L3	--	160L-4	OK	PAGE 150
13.4	9715	2.34	104	40.0	--	EP311R3	160L-4	OK	PAGE 160
13.7	9483	2.93	102	40.0	--	EP313R3	160L-4	OK	PAGE 170
13.8	9411	1.41	101	20.0	--	EP310R3	160L-4	OK	PAGE 150
14.4	9033	2.23	97.0	18.0	EP311L3	--	160L-4	OK	PAGE 160
14.8	8818	3.22	94.7	18.0	EP313L3	--	160L-4	OK	PAGE 170
15.3	8540	0.88	91.7	20.0	--	EP307R3	160L-4	OK	PAGE 130
15.3	8540	1.05	91.7	20.0	--	EP309R3	160L-4	OK	PAGE 140
15.9	8193	2.17	88.0	18.0	EP310L3	--	160L-4	OK	PAGE 150
16.0	8142	2.64	87.5	40.0	--	EP311R3	160L-4	OK	PAGE 160
16.2	8038	1.58	86.3	20.0	--	EP310R3	160L-4	OK	PAGE 150
16.5	7886	2.46	84.7	18.0	EP311L3	--	160L-4	OK	PAGE 160
16.9	7698	3.40	82.7	18.0	EP313L3	--	160L-4	OK	PAGE 170
17.0	7647	1.17	82.1	11.0	EP307L3	--	160L-4	NO !	PAGE 130
17.0	7647	1.64	82.1	11.0	EP309L3	--	160L-4	NO !	PAGE 140
18.5	7039	2.70	75.6	18.0	EP311L3	--	160L-4	OK	PAGE 160
18.7	6978	1.05	75.0	20.0	--	EP307R3	160L-4	OK	PAGE 130
18.7	6978	1.17	75.0	20.0	--	EP309R3	160L-4	OK	PAGE 140
18.9	6902	1.93	74.1	20.0	--	EP310R3	160L-4	OK	PAGE 150
18.9	6882	2.46	73.9	18.0	EP310L3	--	160L-4	OK	PAGE 150
18.9	6882	3.52	73.9	18.0	EP313L3	--	160L-4	OK	PAGE 170
20.5	6344	2.93	68.1	40.0	--	EP311R3	160L-4	OK	PAGE 160
20.8	6263	1.17	67.3	20.0	--	EP307R3	160L-4	OK	PAGE 130
20.8	6263	1.29	67.3	20.0	--	EP309R3	160L-4	OK	PAGE 140
21.2	6152	0.88	66.1	14.0	--	EP306R3	160L-4	NO !	PAGE 120
21.2	6145	2.93	66.0	18.0	EP311L3	--	160L-4	OK	PAGE 160
22.1	5894	2.17	63.3	20.0	--	EP310R3	160L-4	OK	PAGE 150
22.4	5823	1.47	62.5	11.0	EP307L3	--	160L-4	NO !	PAGE 130
22.4	5823	1.93	62.5	11.0	EP309L3	--	160L-4	NO !	PAGE 140
23.6	5521	0.97	59.3	14.0	--	EP306R3	160L-4	NO !	PAGE 120
24.7	5276	2.93	56.7	18.0	EP310L3	--	160L-4	OK	PAGE 150
24.8	5249	1.17	56.4	20.0	--	EP309R3	160L-4	OK	PAGE 140
24.8	5249	1.29	56.4	20.0	--	EP307R3	160L-4	OK	PAGE 130
25.6	5084	1.64	54.6	11.0	EP307L3	--	160L-4	NO !	PAGE 130
25.6	5084	2.11	54.6	11.0	EP309L3	--	160L-4	NO !	PAGE 140
26.1	4999	2.40	53.7	20.0	--	EP310R3	160L-4	OK	PAGE 150
27.6	4715	1.11	50.6	14.0	--	EP306R3	160L-4	NO !	PAGE 120
29.0	4650	0.91	48.3	13.0	EP306L2	--	160L-4	NO !	PAGE 120
29.0	4650	3.04	48.3	22.0	EP310L2	--	160L-4	OK	PAGE 150
29.6	4409	1.17	47.4	20.0	--	EP309R3	160L-4	OK	PAGE 140
29.6	4409	1.47	47.4	20.0	--	EP307R3	160L-4	OK	PAGE 130
31.0	4199	2.64	45.1	20.0	--	EP310R3	160L-4	OK	PAGE 150
32.6	3999	1.35	43.0	14.0	--	EP306R3	160L-4	NO !	PAGE 120
32.9	3961	2.46	42.5	11.0	EP309L3	--	160L-4	NO !	PAGE 140
33.0	4086	1.82	42.5	18.0	EP307L2	--	160L-4	OK	PAGE 130
33.0	4086	2.38	42.5	18.0	EP309L2	--	160L-4	OK	PAGE 140
33.9	3849	1.29	41.3	20.0	--	EP309R3	160L-4	OK	PAGE 140
34.9	3858	0.85	40.1	9.0	EP305L2	--	160L-4	NO !	PAGE 110

EP300 series gear motor

P1=15KW n1=1400 min⁻¹

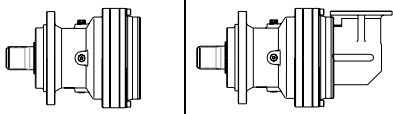
n ₂ (min ⁻¹)	M ₂ (N.m)	S	I 1:	P _t (KW)			IEC Motor type	Check Thermal Power Pt >= P1	Dimension Page Number
35.3	3687	2.64	39.6	20.0	--	EP310R3	160L-4	OK	PAGE 150
35.5	3794	1.25	39.4	13.0	EP306L2	--	160L-4	NO !	PAGE 120
38.8	3359	1.58	36.1	14.0	--	EP306R3	160L-4	NO !	PAGE 120
39.1	3443	2.10	35.8	18.0	EP307L2	--	160L-4	OK	PAGE 130
39.1	3443	3.23	35.8	18.0	EP309L2	--	160L-4	OK	PAGE 140
43.4	3100	1.36	32.2	13.0	EP306L2	--	160L-4	NO !	PAGE 120
43.5	2999	1.47	32.2	20.0	--	EP309R3	160L-4	OK	PAGE 140
43.5	2999	1.76	32.2	20.0	--	EP307R3	160L-4	OK	PAGE 130
43.6	3091	1.02	32.1	9.0	EP305L2	--	160L-4	NO !	PAGE 110
46.7	2885	1.11	30.0	9.0	EP305L2	--	160L-4	NO !	PAGE 110
47.9	2813	2.55	29.3	18.0	EP307L2	--	160L-4	OK	PAGE 130
47.9	2813	3.40	29.3	18.0	EP309L2	--	160L-4	OK	PAGE 140
48.4	2782	1.48	28.9	13.0	EP306L2	--	160L-4	NO !	PAGE 120
48.5	2774	1.13	28.8	9.0	EP305L2	--	160L-4	NO !	PAGE 110
50.6	2575	2.05	27.7	14.0	--	EP306R3	160L-4	NO !	PAGE 120
53.3	2525	2.84	26.3	18.0	EP307L2	--	160L-4	OK	PAGE 130
53.3	2525	3.40	26.3	18.0	EP309L2	--	160L-4	OK	PAGE 140
55.6	2424	1.25	25.2	9.0	EP305L2	--	160L-4	NO !	PAGE 110
56.7	2376	1.70	24.7	13.0	EP306L2	--	160L-4	NO !	PAGE 120
57.8	2330	1.25	24.2	9.0	EP305L2	--	160L-4	NO !	PAGE 110
59.4	2268	2.38	23.6	35.0	--	EP307R2	160L-4	OK	PAGE 130
59.4	2268	2.55	23.6	35.0	--	EP309R2	160L-4	OK	PAGE 140
63.6	2116	3.12	22.0	18.0	EP307L2	--	160L-4	OK	PAGE 130
63.6	2116	3.40	22.0	18.0	EP309L2	--	160L-4	OK	PAGE 140
66.8	2015	2.27	21.0	13.0	EP306L2	--	160L-4	NO !	PAGE 120
70.4	1911	2.55	19.9	35.0	--	EP307R2	160L-4	OK	PAGE 130
70.4	1911	2.55	19.9	35.0	--	EP309R2	160L-4	OK	PAGE 140
75.0	1795	1.42	18.7	9.0	EP305L2	--	160L-4	NO !	PAGE 110
75.8	1777	3.40	18.5	18.0	EP307L2	--	160L-4	OK	PAGE 130
75.8	1777	3.40	18.5	18.0	EP309L2	--	160L-4	OK	PAGE 140
77.0	1747	1.99	18.2	18.0	--	EP306R2	160L-4	OK	PAGE 120
79.5	1693	2.27	17.6	13.0	EP306L2	--	160L-4	NO !	PAGE 120
84.0	1602	2.84	16.7	35.0	--	EP307R2	160L-4	OK	PAGE 130
84.0	1602	2.84	16.7	35.0	--	EP309R2	160L-4	OK	PAGE 140
86.8	1552	3.40	16.1	18.0	EP307L2	--	160L-4	OK	PAGE 130
86.8	1552	3.40	16.1	18.0	EP307L2	--	160L-4	OK	PAGE 130
86.8	1552	3.40	16.1	18.0	EP309L2	--	160L-4	OK	PAGE 140
94.4	1426	1.99	14.8	18.0	--	EP306R2	160L-4	OK	PAGE 120
98.1	1373	1.07	14.3	18.0	--	EP303R2	160L-4	OK	PAGE 100
98.1	1373	1.07	14.3	18.0	--	EP305R2	160L-4	OK	PAGE 110
98.5	1367	1.70	14.2	9.0	EP305L2	--	160L-4	NO !	PAGE 110
104	1298	2.27	13.5	13.0	EP306L2	--	160L-4	NO !	PAGE 120
108	1248	3.40	13.0	35.0	--	EP309R2	160L-4	OK	PAGE 140
109	1232	1.53	12.8	18.0	--	EP303R2	160L-4	OK	PAGE 100
109	1232	1.53	12.8	18.0	--	EP305R2	160L-4	OK	PAGE 110
111	1218	1.99	12.7	18.0	--	EP306R2	160L-4	OK	PAGE 120
111	1209	3.40	12.6	18.0	EP307L2	--	160L-4	OK	PAGE 130
111	1209	3.40	12.6	18.0	EP309L2	--	160L-4	OK	PAGE 140
113	1194	1.70	12.4	9.0	EP305L2	--	160L-4	NO !	PAGE 110
130	1035	1.99	10.8	18.0	--	EP303R2	160L-4	OK	PAGE 100
130	1035	1.99	10.8	18.0	--	EP305R2	160L-4	OK	PAGE 110

EP300 series gear motor

P1=15KW n1=1400 min⁻¹

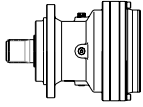
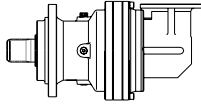
n ₂ (min ⁻¹)	M ₂ (N.m)	S	I 1:	P _t (KW)			IEC Motor type	Check Thermal	Dimension
								Power Pt >= P1	Page Number
130	1033	1.99	10.7	18.0	--	EP306R2	160L-4	OK	PAGE 120
148	907	1.99	9.4	18.0	--	EP306R2	160L-4	OK	PAGE 120
149	904	1.99	9.4	18.0	--	EP303R2	160L-4	OK	PAGE 100
149	904	1.99	9.4	18.0	--	EP305R2	160L-4	OK	PAGE 110
205	677	1.98	6.8	11.0	EP303L1	--	160L-4	NO !	PAGE 100
205	677	2.75	6.8	13.0	EP305L1	--	160L-4	NO !	PAGE 110
251	553	2.20	5.6	11.0	EP303L1	--	160L-4	NO !	PAGE 100
251	553	3.30	5.6	13.0	EP305L1	--	160L-4	NO !	PAGE 110
280	496	2.20	5.0	11.0	EP303L1	--	160L-4	NO !	PAGE 100
280	496	2.20	5.0	11.0	EP303L1	--	160L-4	NO !	PAGE 100
280	496	3.30	5.0	13.0	EP305L1	--	160L-4	NO !	PAGE 110
333	417	2.20	4.2	11.0	EP303L1	--	160L-4	NO !	PAGE 100
333	417	3.30	4.2	13.0	EP305L1	--	160L-4	NO !	PAGE 110
382	364	2.20	3.7	11.0	EP303L1	--	160L-4	NO !	PAGE 100
382	364	3.30	3.7	13.0	EP305L1	--	160L-4	NO !	PAGE 110

EP300 series gear motor

P1=18.5KW n1=1400 min⁻¹

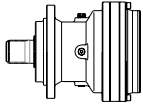
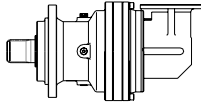
n ₂ (min ⁻¹)	M ₂ (N.m)	S	I 1:	P _t (KW)			IEC Motor type	Check Thermal	Dimension
								Power Pt >= P1	Page Number
1.2	130021	0.88	1171	18.0	EP316L4	--	180M-4	NO !	PAGE 190
1.4	108970	1.08	981	18.0	EP316L4	--	180M-4	NO !	PAGE 190
1.7	91817	1.23	827	18.0	EP316L4	--	180M-4	NO !	PAGE 190
1.8	85679	1.38	772	45.0	--	EP316R4	180M-4	OK	PAGE 190
2.0	78746	1.03	709	18.0	EP315L4	--	180M-4	NO !	PAGE 180
2.1	75028	1.47	676	18.0	EP316L4	--	180M-4	NO !	PAGE 190
2.2	72223	1.03	650	40.0	--	EP315R4	180M-4	OK	PAGE 180
2.2	72193	1.62	650	45.0	--	EP316R4	180M-4	OK	PAGE 190
2.2	70670	1.13	636	18.0	EP315L4	--	180M-4	NO !	PAGE 180
2.3	67333	1.67	606	18.0	EP316L4	--	180M-4	NO !	PAGE 190
2.6	60504	1.97	545	45.0	--	EP316R4	180M-4	OK	PAGE 190
2.6	60354	1.28	544	18.0	EP315L4	--	180M-4	NO !	PAGE 180
2.6	58930	1.13	531	40.0	--	EP315R4	180M-4	OK	PAGE 180
2.8	56431	1.97	508	18.0	EP316L4	--	180M-4	NO !	PAGE 190
3.0	52200	0.86	470	22.0	--	EP313R4	180M-4	OK	PAGE 170
3.0	51288	1.28	462	40.0	--	EP315R4	180M-4	OK	PAGE 180
3.0	51185	1.47	461	18.0	EP315L4	--	180M-4	NO !	PAGE 180
3.0	50980	2.21	459	45.0	--	EP316R4	180M-4	OK	PAGE 190
3.3	47402	2.31	427	18.0	EP316L4	--	180M-4	NO !	PAGE 190
3.5	43972	2.51	396	18.0	EP316L4	--	180M-4	NO !	PAGE 190
3.6	43215	1.57	389	40.0	--	EP315R4	180M-4	OK	PAGE 180
3.6	42995	1.72	387	18.0	EP315L4	--	180M-4	NO !	PAGE 180
3.6	42726	2.56	385	45.0	--	EP316R4	180M-4	OK	PAGE 190
3.6	42655	1.03	384	22.0	--	EP313R4	180M-4	OK	PAGE 170
4.1	38280	1.13	345	22.0	--	EP313R4	180M-4	OK	PAGE 170
4.2	37458	2.46	337	18.0	EP315L4	--	180M-4	NO !	PAGE 180
4.2	36937	2.95	333	18.0	EP316L4	--	180M-4	NO !	PAGE 190

EP300 series gear motor

P1=18.5KW n1=1400 min⁻¹

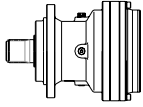
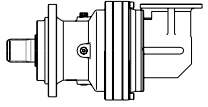
n ₂ (min ⁻¹)	M ₂ (N.m)	S	I 1:	P _t (KW)			IEC Motor type	Check Thermal	Dimension
								Power Pt >= P1	Page Number
4.3	36218	2.11	326	40.0	--	EP315R4	180M-4	OK	PAGE 180
4.4	34956	0.91	315	22.0	--	EP311R4	180M-4	OK	PAGE 160
4.6	34590	1.77	301	30.0	EP315L3	--	180M-4	OK	PAGE 180
4.7	33293	2.95	300	45.0	--	EP316R4	180M-4	OK	PAGE 190
4.8	32246	2.95	290	18.0	EP316L4	--	180M-4	NO !	PAGE 190
4.8	32082	1.33	289	22.0	--	EP313R4	180M-4	OK	PAGE 170
5.0	31371	1.01	283	22.0	--	EP311R4	180M-4	OK	PAGE 160
5.0	30932	2.46	279	40.0	--	EP315R4	180M-4	OK	PAGE 180
5.4	29644	1.47	258	18.0	EP313L3	--	180M-4	NO !	PAGE 170
5.5	29146	2.33	254	30.0	EP315L3	--	180M-4	OK	PAGE 180
5.8	26949	1.52	243	22.0	--	EP313R4	180M-4	OK	PAGE 170
5.9	26292	1.13	237	22.0	--	EP311R4	180M-4	OK	PAGE 160
5.9	26232	2.95	236	40.0	--	EP315R4	180M-4	OK	PAGE 180
6.2	25127	2.95	226	18.0	EP316L4	--	180M-4	NO !	PAGE 190
6.3	25610	1.05	223	18.0	EP311L3	--	180M-4	NO !	PAGE 160
6.4	25000	1.71	218	18.0	EP313L3	--	180M-4	NO !	PAGE 170
6.6	23527	1.72	212	22.0	--	EP313R4	180M-4	OK	PAGE 170
6.8	23781	2.77	207	30.0	EP315L3	--	180M-4	OK	PAGE 180
6.9	23404	2.77	204	30.0	EP316L3	--	180M-4	OK	PAGE 190
7.0	22085	1.28	199	22.0	--	EP311R4	180M-4	OK	PAGE 160
7.1	22035	3.44	198	40.0	--	EP315R4	180M-4	OK	PAGE 180
7.1	22648	0.90	197	18.0	EP310L3	--	180M-4	NO !	PAGE 150
7.4	21033	1.72	189	22.0	--	EP313R4	180M-4	OK	PAGE 170
7.4	21579	1.19	188	18.0	EP311L3	--	180M-4	NO !	PAGE 160
7.6	21065	1.90	183	18.0	EP313L3	--	180M-4	NO !	PAGE 170
7.8	20697	3.05	180	30.0	EP315L3	--	180M-4	OK	PAGE 180
8.1	19281	1.43	174	22.0	--	EP311R4	180M-4	OK	PAGE 160
8.2	19720	3.05	172	30.0	EP316L3	--	180M-4	OK	PAGE 190
8.5	18363	1.72	165	22.0	--	EP313R4	180M-4	OK	PAGE 170
8.7	18507	1.05	161	18.0	EP310L3	--	180M-4	NO !	PAGE 150
9.0	17209	1.57	155	22.0	--	EP311R4	180M-4	OK	PAGE 160
9.1	17633	1.33	154	18.0	EP311L3	--	180M-4	NO !	PAGE 160
9.3	17213	2.14	150	18.0	EP313L3	--	180M-4	NO !	PAGE 170
9.7	16609	1.14	145	18.0	EP310L3	--	180M-4	NO !	PAGE 150
9.8	16459	1.90	143	40.0	--	EP313R3	180M-4	OK	PAGE 170
10.2	15825	1.43	138	18.0	EP311L3	--	180M-4	NO !	PAGE 160
10.4	15448	2.38	135	18.0	EP313L3	--	180M-4	NO !	PAGE 170
10.9	14308	1.72	129	22.0	--	EP313R4	180M-4	OK	PAGE 170
11.3	14226	0.95	124	20.0	--	EP310R3	180M-4	OK	PAGE 150
11.3	14220	1.66	124	40.0	--	EP311R3	180M-4	OK	PAGE 160
11.3	14184	1.33	124	18.0	EP310L3	--	180M-4	NO !	PAGE 150
11.6	13881	2.14	121	40.0	--	EP313R3	180M-4	OK	PAGE 170
12.1	13262	1.66	116	18.0	EP311L3	--	180M-4	NO !	PAGE 160
12.4	12947	2.61	113	18.0	EP313L3	--	180M-4	NO !	PAGE 170
13.1	12242	1.09	107	11.0	EP309L3	--	180M-4	NO !	PAGE 140
13.4	12029	1.52	105	18.0	EP310L3	--	180M-4	NO !	PAGE 150
13.4	11981	1.90	104	40.0	--	EP311R3	180M-4	OK	PAGE 160
13.7	11696	2.38	102	40.0	--	EP313R3	180M-4	OK	PAGE 170
13.8	11607	1.14	101	20.0	--	EP310R3	180M-4	OK	PAGE 150
14.4	11140	1.81	97.0	18.0	EP311L3	--	180M-4	NO !	PAGE 160
14.8	10875	2.61	94.7	18.0	EP313L3	--	180M-4	NO !	PAGE 170

EP300 series gear motor

P1=18.5KW n1=1400 min⁻¹

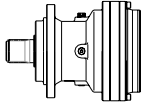
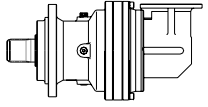
n₂ (min ⁻¹)	M₂ (N.m)	S	I 1:	P_t (KW)			IEC Motor type	Check Thermal Power Pt >= P1	Dimension Page Number
15.9	10105	1.76	88.0	18.0	EP310L3	--	180M-4	NO !	PAGE 150
16.0	10042	2.14	87.5	40.0	--	EP311R3	180M-4	OK	PAGE 160
16.2	9913	1.28	86.3	20.0	--	EP310R3	180M-4	OK	PAGE 150
16.4	9803	2.85	85.4	40.0	--	EP313R3	180M-4	OK	PAGE 170
16.5	9726	2.00	84.7	18.0	EP311L3	--	180M-4	NO !	PAGE 160
16.9	9494	2.76	82.7	18.0	EP313L3	--	180M-4	NO !	PAGE 170
17.0	9431	0.95	82.1	11.0	EP307L3	--	180M-4	NO !	PAGE 130
17.0	9431	1.33	82.1	11.0	EP309L3	--	180M-4	NO !	PAGE 140
18.5	8681	2.19	75.6	18.0	EP311L3	--	180M-4	NO !	PAGE 160
18.7	8607	0.86	75.0	20.0	--	EP307R3	180M-4	OK	PAGE 130
18.9	8512	1.57	74.1	20.0	--	EP310R3	180M-4	OK	PAGE 150
18.9	8488	2.00	73.9	18.0	EP310L3	--	180M-4	NO !	PAGE 150
18.9	8488	2.85	73.9	18.0	EP313L3	--	180M-4	NO !	PAGE 170
20.5	7825	2.38	68.1	40.0	--	EP311R3	180M-4	OK	PAGE 160
20.8	7724	0.95	67.3	20.0	--	EP307R3	180M-4	OK	PAGE 130
21.0	7651	2.85	66.6	40.0	--	EP313R3	180M-4	OK	PAGE 170
21.2	7579	2.38	66.0	18.0	EP311L3	--	180M-4	NO !	PAGE 160
21.7	7410	3.09	64.5	18.0	EP313L3	--	180M-4	NO !	PAGE 170
22.1	7270	1.76	63.3	20.0	--	EP310R3	180M-4	OK	PAGE 150
22.4	7182	1.19	62.5	11.0	EP307L3	--	180M-4	NO !	PAGE 130
22.4	7182	1.57	62.5	11.0	EP309L3	--	180M-4	NO !	PAGE 140
24.7	6507	2.38	56.7	18.0	EP310L3	--	180M-4	NO !	PAGE 150
24.8	6473	1.05	56.4	20.0	--	EP307R3	180M-4	OK	PAGE 130
25.6	6270	1.33	54.6	11.0	EP307L3	--	180M-4	NO !	PAGE 130
25.6	6270	1.71	54.6	11.0	EP309L3	--	180M-4	NO !	PAGE 140
26.1	6165	1.95	53.7	20.0	--	EP310R3	180M-4	OK	PAGE 150
26.4	6097	2.85	53.1	40.0	--	EP311R3	180M-4	OK	PAGE 160
27.2	5905	2.85	51.4	18.0	EP311L3	--	180M-4	NO !	PAGE 160
27.6	5816	0.90	50.6	14.0	--	EP306R3	180M-4	NO !	PAGE 120
29.0	5735	2.47	48.3	22.0	EP310L2	--	180M-4	OK	PAGE 150
29.6	5438	1.19	47.4	20.0	--	EP307R3	180M-4	OK	PAGE 130
31.0	5179	2.14	45.1	20.0	--	EP310R3	180M-4	OK	PAGE 150
32.6	4932	1.09	43.0	14.0	--	EP306R3	180M-4	NO !	PAGE 120
32.9	4886	2.00	42.5	11.0	EP309L3	--	180M-4	NO !	PAGE 140
33.0	5039	1.47	42.5	18.0	EP307L2	--	180M-4	NO !	PAGE 130
33.0	5039	1.93	42.5	18.0	EP309L2	--	180M-4	NO !	PAGE 140
33.9	4747	1.05	41.3	20.0	--	EP309R3	180M-4	OK	PAGE 140
35.3	4548	2.14	39.6	20.0	--	EP310R3	180M-4	OK	PAGE 150
35.5	4679	2.95	39.4	22.0	EP310L2	--	180M-4	OK	PAGE 150
38.8	4143	1.28	36.1	14.0	--	EP306R3	180M-4	NO !	PAGE 120
39.1	4246	1.70	35.8	18.0	EP307L2	--	180M-4	NO !	PAGE 130
39.1	4246	2.62	35.8	18.0	EP309L2	--	180M-4	NO !	PAGE 140
43.5	3699	1.19	32.2	20.0	--	EP309R3	180M-4	OK	PAGE 140
43.5	3699	1.43	32.2	20.0	--	EP307R3	180M-4	OK	PAGE 130
47.9	3469	2.07	29.3	18.0	EP307L2	--	180M-4	NO !	PAGE 130
47.9	3469	2.76	29.3	18.0	EP309L2	--	180M-4	NO !	PAGE 140
50.6	3176	1.66	27.7	14.0	--	EP306R3	180M-4	NO !	PAGE 120
53.3	3114	2.30	26.3	18.0	EP307L2	--	180M-4	NO !	PAGE 130
53.3	3114	2.76	26.3	18.0	EP309L2	--	180M-4	NO !	PAGE 140
59.4	2798	1.93	23.6	35.0	--	EP307R2	180M-4	OK	PAGE 130
59.4	2798	2.07	23.6	35.0	--	EP309R2	180M-4	OK	PAGE 140

EP300 series gear motor

P1=18.5KW n1=1400 min⁻¹

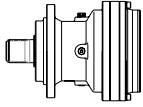
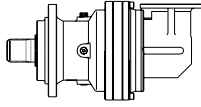
n₂ (min ⁻¹)	M₂ (N.m)	S	I 1:	P_t (KW)			IEC Motor type	Check Thermal Power Pt >= P1	Dimension Page Number
63.6	2609	2.53	22.0	18.0	EP307L2	--	180M-4	NO !	PAGE 130
63.6	2609	2.76	22.0	18.0	EP309L2	--	180M-4	NO !	PAGE 140
70.4	2357	2.07	19.9	35.0	--	EP307R2	180M-4	OK	PAGE 130
70.4	2357	2.07	19.9	35.0	--	EP309R2	180M-4	OK	PAGE 140
75.8	2192	2.76	18.5	18.0	EP307L2	--	180M-4	NO !	PAGE 130
75.8	2192	2.76	18.5	18.0	EP309L2	--	180M-4	NO !	PAGE 140
77.0	2155	1.61	18.2	18.0	--	EP306R2	180M-4	NO !	PAGE 120
84.0	1976	2.30	16.7	35.0	--	EP307R2	180M-4	OK	PAGE 130
84.0	1976	2.30	16.7	35.0	--	EP309R2	180M-4	OK	PAGE 140
86.8	1914	2.76	16.1	18.0	EP307L2	--	180M-4	NO !	PAGE 130
86.8	1914	2.76	16.1	18.0	EP307L2	--	180M-4	NO !	PAGE 130
86.8	1914	2.76	16.1	18.0	EP309L2	--	180M-4	NO !	PAGE 140
94.4	1759	1.61	14.8	18.0	--	EP306R2	180M-4	NO !	PAGE 120
98.1	1693	0.87	14.3	18.0	--	EP303R2	180M-4	NO !	PAGE 100
98.1	1693	0.87	14.3	18.0	--	EP305R2	180M-4	NO !	PAGE 110
108	1540	2.76	13.0	35.0	--	EP307R2	180M-4	OK	PAGE 130
108	1540	2.76	13.0	35.0	--	EP307R2	180M-4	OK	PAGE 130
108	1540	2.76	13.0	35.0	--	EP307R2	180M-4	OK	PAGE 130
108	1540	2.76	13.0	35.0	--	EP307R2	180M-4	OK	PAGE 130
108	1540	2.76	13.0	35.0	--	EP309R2	180M-4	OK	PAGE 140
109	1520	1.24	12.8	18.0	--	EP303R2	180M-4	NO !	PAGE 100
109	1520	1.24	12.8	18.0	--	EP305R2	180M-4	NO !	PAGE 110
111	1502	1.61	12.7	18.0	--	EP306R2	180M-4	NO !	PAGE 120
111	1491	2.76	12.6	18.0	EP307L2	--	180M-4	NO !	PAGE 130
111	1491	2.76	12.6	18.0	EP309L2	--	180M-4	NO !	PAGE 140
130	1277	1.61	10.8	18.0	--	EP303R2	180M-4	NO !	PAGE 100
130	1277	1.61	10.8	18.0	--	EP305R2	180M-4	NO !	PAGE 110
130	1274	1.61	10.7	18.0	--	EP306R2	180M-4	NO !	PAGE 120
148	1119	1.61	9.4	18.0	--	EP306R2	180M-4	NO !	PAGE 120
149	1114	1.61	9.4	18.0	--	EP303R2	180M-4	NO !	PAGE 100
149	1114	1.61	9.4	18.0	--	EP305R2	180M-4	NO !	PAGE 110
197	868	3.12	7.1	18.0	EP306L1	--	180M-4	NO !	PAGE 120
205	835	2.23	6.8	13.0	EP305L1	--	180M-4	NO !	PAGE 110
251	682	2.67	5.6	13.0	EP305L1	--	180M-4	NO !	PAGE 110
280	612	2.67	5.0	13.0	EP305L1	--	180M-4	NO !	PAGE 110
333	514	2.67	4.2	13.0	EP305L1	--	180M-4	NO !	PAGE 110
382	449	2.67	3.7	13.0	EP305L1	--	180M-4	NO !	PAGE 110

EP300 series gear motor

P1=22KW n1=1400 min⁻¹

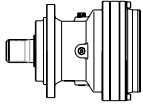
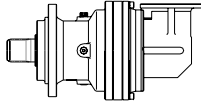
n₂ (min ⁻¹)	M₂ (N.m)	S	I 1:	P_t (KW)			IEC Motor type	Check Thermal Power Pt >= P1	Dimension Page Number
1.8	101889	1.16	772	45.0	--	EP316R4	180L-4	OK	PAGE 190
2.2	85887	0.87	650	40.0	--	EP315R4	180L-4	OK	PAGE 180
2.2	85851	1.36	650	45.0	--	EP316R4	180L-4	OK	PAGE 190
2.2	84040	0.95	636	18.0	EP315L4	--	180L-4	NO !	PAGE 180
2.6	71951	1.65	545	45.0	--	EP316R4	180L-4	OK	PAGE 190

EP300 series gear motor

P1=22KW n1=1400 min⁻¹

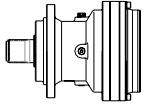
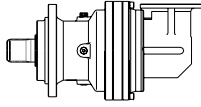
n ₂ (min ⁻¹)	M ₂ (N.m)	S	I 1:	P _t (KW)			IEC Motor type	Check Thermal	Dimension
								Power Pt >= P1	Page Number
2.6	71773	1.07	544	18.0	EP315L4	--	180L-4	NO !	PAGE 180
2.6	70078	0.95	531	40.0	--	EP315R4	180L-4	OK	PAGE 180
3.0	60991	1.07	462	40.0	--	EP315R4	180L-4	OK	PAGE 180
3.0	60868	1.24	461	18.0	EP315L4	--	180L-4	NO !	PAGE 180
3.0	60625	1.86	459	45.0	--	EP316R4	180L-4	OK	PAGE 190
3.6	51391	1.32	389	40.0	--	EP315R4	180L-4	OK	PAGE 180
3.6	51129	1.45	387	18.0	EP315L4	--	180L-4	NO !	PAGE 180
3.6	50810	2.15	385	45.0	--	EP316R4	180L-4	OK	PAGE 190
3.6	50725	0.87	384	22.0	--	EP313R4	180L-4	OK	PAGE 170
4.1	45522	0.95	345	22.0	--	EP313R4	180L-4	OK	PAGE 170
4.2	44545	2.07	337	18.0	EP315L4	--	180L-4	NO !	PAGE 180
4.3	43070	1.78	326	40.0	--	EP315R4	180L-4	OK	PAGE 180
4.6	41134	1.49	301	30.0	EP315L3	--	180L-4	OK	PAGE 180
4.7	39592	2.48	300	45.0	--	EP316R4	180L-4	OK	PAGE 190
4.8	38152	1.12	289	22.0	--	EP313R4	180L-4	OK	PAGE 170
5.0	37306	0.85	283	22.0	--	EP311R4	180L-4	OK	PAGE 160
5.0	36783	2.07	279	40.0	--	EP315R4	180L-4	OK	PAGE 180
5.4	35252	1.24	258	18.0	EP313L3	--	180L-4	NO !	PAGE 170
5.5	34660	1.96	254	30.0	EP315L3	--	180L-4	OK	PAGE 180
5.8	32048	1.28	243	22.0	--	EP313R4	180L-4	OK	PAGE 170
5.9	31266	0.95	237	22.0	--	EP311R4	180L-4	OK	PAGE 160
5.9	31195	2.48	236	40.0	--	EP315R4	180L-4	OK	PAGE 180
6.0	30851	3.10	234	45.0	--	EP316R4	180L-4	OK	PAGE 190
6.3	30455	0.88	223	18.0	EP311L3	--	180L-4	NO !	PAGE 160
6.4	29730	1.44	218	18.0	EP313L3	--	180L-4	NO !	PAGE 170
6.6	27978	1.45	212	22.0	--	EP313R4	180L-4	OK	PAGE 170
6.8	28280	2.33	207	30.0	EP315L3	--	180L-4	OK	PAGE 180
6.9	27831	2.33	204	30.0	EP316L3	--	180L-4	OK	PAGE 190
7.0	26263	1.07	199	22.0	--	EP311R4	180L-4	OK	PAGE 160
7.1	26204	2.89	198	40.0	--	EP315R4	180L-4	OK	PAGE 180
7.4	25013	1.45	189	22.0	--	EP313R4	180L-4	OK	PAGE 170
7.4	25661	1.00	188	18.0	EP311L3	--	180L-4	NO !	PAGE 160
7.6	25050	1.60	183	18.0	EP313L3	--	180L-4	NO !	PAGE 170
7.8	24613	2.56	180	30.0	EP315L3	--	180L-4	OK	PAGE 180
8.1	22928	1.20	174	22.0	--	EP311R4	180L-4	OK	PAGE 160
8.1	22829	3.31	173	40.0	--	EP315R4	180L-4	OK	PAGE 180
8.2	23451	2.56	172	30.0	EP316L3	--	180L-4	OK	PAGE 190
8.5	21837	1.45	165	22.0	--	EP313R4	180L-4	OK	PAGE 170
8.7	22008	0.88	161	18.0	EP310L3	--	180L-4	NO !	PAGE 150
9.0	20465	1.32	155	22.0	--	EP311R4	180L-4	OK	PAGE 160
9.1	20969	1.12	154	18.0	EP311L3	--	180L-4	NO !	PAGE 160
9.2	20739	3.03	152	30.0	EP315L3	--	180L-4	OK	PAGE 180
9.2	20048	3.31	152	40.0	--	EP315R4	180L-4	OK	PAGE 180
9.3	20470	1.80	150	18.0	EP313L3	--	180L-4	NO !	PAGE 170
9.7	19751	0.96	145	18.0	EP310L3	--	180L-4	NO !	PAGE 150
9.8	19573	1.60	143	40.0	--	EP313R3	180L-4	OK	PAGE 170
10.2	18818	1.20	138	18.0	EP311L3	--	180L-4	NO !	PAGE 160
10.4	18370	2.00	135	18.0	EP313L3	--	180L-4	NO !	PAGE 170
10.9	17015	1.45	129	22.0	--	EP313R4	180L-4	OK	PAGE 170
11.3	16989	3.50	124	75.0	--	EP315R3	180L-4	OK	PAGE 180
11.3	16910	1.40	124	40.0	--	EP311R3	180L-4	OK	PAGE 160

EP300 series gear motor

P1=22KW n1=1400 min⁻¹

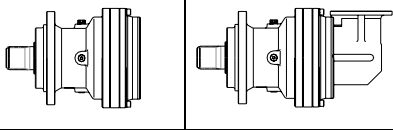
n ₂ (min ⁻¹)	M ₂ (N.m)	S	I 1:	P _t (KW)			IEC Motor type	Check Thermal Power Pt >= P1	Dimension Page Number
11.3	16868	1.12	124	18.0	EP310L3	--	180L-4	NO !	PAGE 150
11.6	16507	1.80	121	40.0	--	EP313R3	180L-4	OK	PAGE 170
12.1	15772	1.40	116	18.0	EP311L3	--	180L-4	NO !	PAGE 160
12.4	15396	2.20	113	18.0	EP313L3	--	180L-4	NO !	PAGE 170
13.4	14305	1.28	105	18.0	EP310L3	--	180L-4	NO !	PAGE 150
13.4	14248	1.60	104	40.0	--	EP311R3	180L-4	OK	PAGE 160
13.7	13909	2.00	102	40.0	--	EP313R3	180L-4	OK	PAGE 170
14.4	13248	1.52	97.0	18.0	EP311L3	--	180L-4	NO !	PAGE 160
14.8	12933	2.20	94.7	18.0	EP313L3	--	180L-4	NO !	PAGE 170
15.9	12016	1.48	88.0	18.0	EP310L3	--	180L-4	NO !	PAGE 150
16.0	11941	1.80	87.5	40.0	--	EP311R3	180L-4	OK	PAGE 160
16.2	11788	1.08	86.3	20.0	--	EP310R3	180L-4	NO !	PAGE 150
16.4	11657	2.40	85.4	40.0	--	EP313R3	180L-4	OK	PAGE 170
16.5	11566	1.68	84.7	18.0	EP311L3	--	180L-4	NO !	PAGE 160
16.9	11290	2.32	82.7	18.0	EP313L3	--	180L-4	NO !	PAGE 170
17.0	11215	1.12	82.1	11.0	EP309L3	--	180L-4	NO !	PAGE 140
18.5	10323	1.84	75.6	18.0	EP311L3	--	180L-4	NO !	PAGE 160
18.9	10122	1.32	74.1	20.0	--	EP310R3	180L-4	NO !	PAGE 150
18.9	10094	1.68	73.9	18.0	EP310L3	--	180L-4	NO !	PAGE 150
18.9	10094	2.40	73.9	18.0	EP313L3	--	180L-4	NO !	PAGE 170
20.5	9305	2.00	68.1	40.0	--	EP311R3	180L-4	OK	PAGE 160
21.0	9098	2.40	66.6	40.0	--	EP313R3	180L-4	OK	PAGE 170
21.2	9012	2.00	66.0	18.0	EP311L3	--	180L-4	NO !	PAGE 160
21.7	8812	2.60	64.5	18.0	EP313L3	--	180L-4	NO !	PAGE 170
22.1	8645	1.48	63.3	20.0	--	EP310R3	180L-4	NO !	PAGE 150
22.4	8541	1.00	62.5	11.0	EP307L3	--	180L-4	NO !	PAGE 130
22.4	8541	1.32	62.5	11.0	EP309L3	--	180L-4	NO !	PAGE 140
24.7	7739	2.00	56.7	18.0	EP310L3	--	180L-4	NO !	PAGE 150
24.8	7698	0.88	56.4	20.0	--	EP307R3	180L-4	NO !	PAGE 130
25.6	7456	1.12	54.6	11.0	EP307L3	--	180L-4	NO !	PAGE 130
25.6	7456	1.44	54.6	11.0	EP309L3	--	180L-4	NO !	PAGE 140
26.1	7331	1.64	53.7	20.0	--	EP310R3	180L-4	NO !	PAGE 150
26.4	7251	2.40	53.1	40.0	--	EP311R3	180L-4	OK	PAGE 160
27.0	7089	2.80	51.9	40.0	--	EP313R3	180L-4	OK	PAGE 170
27.2	7023	2.40	51.4	18.0	EP311L3	--	180L-4	NO !	PAGE 160
27.8	6867	3.20	50.3	18.0	EP313L3	--	180L-4	NO !	PAGE 170
29.0	6819	2.08	48.3	22.0	EP310L2	--	180L-4	OK	PAGE 150
29.6	6466	1.00	47.4	20.0	--	EP307R3	180L-4	NO !	PAGE 130
31.0	6158	1.80	45.1	20.0	--	EP310R3	180L-4	NO !	PAGE 150
32.9	5810	1.68	42.5	11.0	EP309L3	--	180L-4	NO !	PAGE 140
33.0	5992	1.24	42.5	18.0	EP307L2	--	180L-4	NO !	PAGE 130
33.0	5992	1.62	42.5	18.0	EP309L2	--	180L-4	NO !	PAGE 140
35.3	5408	1.80	39.6	20.0	--	EP310R3	180L-4	NO !	PAGE 150
35.5	5564	2.48	39.4	22.0	EP310L2	--	180L-4	OK	PAGE 150
36.1	5476	3.61	38.8	25.0	EP311L2	--	180L-4	OK	PAGE 160
39.1	5049	1.43	35.8	18.0	EP307L2	--	180L-4	NO !	PAGE 130
39.1	5049	2.21	35.8	18.0	EP309L2	--	180L-4	NO !	PAGE 140
41.6	4752	2.93	33.7	22.0	EP310L2	--	180L-4	OK	PAGE 150
43.5	4399	1.00	32.2	20.0	--	EP309R3	180L-4	NO !	PAGE 140
43.5	4399	1.20	32.2	20.0	--	EP307R3	180L-4	NO !	PAGE 130
47.9	4126	1.74	29.3	18.0	EP307L2	--	180L-4	NO !	PAGE 130

EP300 series gear motor

P1=22KW n1=1400 min⁻¹

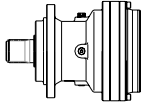
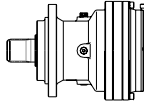
n ₂ (min ⁻¹)	M ₂ (N.m)	S	I 1:	P _t (KW)			IEC Motor type	Check Thermal	Dimension
								Power Pt >= P1	Page Number
47.9	4126	2.32	29.3	18.0	EP309L2	--	180L-4	NO !	PAGE 140
48.4	4080	3.16	28.9	22.0	EP310L2	--	180L-4	OK	PAGE 150
53.3	3703	1.93	26.3	18.0	EP307L2	--	180L-4	NO !	PAGE 130
53.3	3703	2.32	26.3	18.0	EP309L2	--	180L-4	NO !	PAGE 140
56.7	3485	3.38	24.7	22.0	EP310L2	--	180L-4	OK	PAGE 150
59.4	3327	1.62	23.6	35.0	--	EP307R2	180L-4	OK	PAGE 130
59.4	3327	1.74	23.6	35.0	--	EP309R2	180L-4	OK	PAGE 140
63.6	3103	2.13	22.0	18.0	EP307L2	--	180L-4	NO !	PAGE 130
63.6	3103	2.32	22.0	18.0	EP309L2	--	180L-4	NO !	PAGE 140
70.4	2803	1.74	19.9	35.0	--	EP307R2	180L-4	OK	PAGE 130
70.4	2803	1.74	19.9	35.0	--	EP309R2	180L-4	OK	PAGE 140
75.8	2607	2.32	18.5	18.0	EP307L2	--	180L-4	NO !	PAGE 130
75.8	2607	2.32	18.5	18.0	EP309L2	--	180L-4	NO !	PAGE 140
84.0	2350	1.93	16.7	35.0	--	EP307R2	180L-4	OK	PAGE 130
84.0	2350	1.93	16.7	35.0	--	EP309R2	180L-4	OK	PAGE 140
86.8	2276	2.32	16.1	18.0	EP307L2	--	180L-4	NO !	PAGE 130
86.8	2276	2.32	16.1	18.0	EP307L2	--	180L-4	NO !	PAGE 130
86.8	2276	2.32	16.1	18.0	EP309L2	--	180L-4	NO !	PAGE 140
108	1831	2.32	13.0	35.0	--	EP307R2	180L-4	OK	PAGE 130
108	1831	2.32	13.0	35.0	--	EP307R2	180L-4	OK	PAGE 130
108	1831	2.32	13.0	35.0	--	EP307R2	180L-4	OK	PAGE 130
108	1831	2.32	13.0	35.0	--	EP307R2	180L-4	OK	PAGE 130
108	1831	2.32	13.0	35.0	--	EP309R2	180L-4	OK	PAGE 140
111	1773	2.32	12.6	18.0	EP307L2	--	180L-4	NO !	PAGE 130
111	1773	2.32	12.6	18.0	EP309L2	--	180L-4	NO !	PAGE 140
197	1032	2.62	7.1	18.0	EP306L1	--	180L-4	NO !	PAGE 120
242	842	3.28	5.8	18.0	EP306L1	--	180L-4	NO !	PAGE 120
283	719	3.28	4.9	18.0	EP306L1	--	180L-4	NO !	PAGE 120
334	610	3.28	4.2	18.0	EP306L1	--	180L-4	NO !	PAGE 120
380	536	3.28	3.7	18.0	EP306L1	--	180L-4	NO !	PAGE 120

EP300 series gear motor

P1=30KW n1=1400 min⁻¹

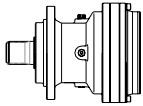
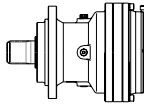
n ₂ (min ⁻¹)	M ₂ (N.m)	S	I 1:	P _t (KW)			IEC Motor type	Check Thermal	Dimension
								Power Pt >= P1	Page Number
1.8	138939	0.85	772	45.0	--	EP316R4	200L-4	OK	PAGE 190
2.2	117069	1.00	650	45.0	--	EP316R4	200L-4	OK	PAGE 190
2.6	98115	1.21	545	45.0	--	EP316R4	200L-4	OK	PAGE 190
3.0	82671	1.36	459	45.0	--	EP316R4	200L-4	OK	PAGE 190
3.6	70078	0.97	389	40.0	--	EP315R4	200L-4	OK	PAGE 180
3.6	69286	1.58	385	45.0	--	EP316R4	200L-4	OK	PAGE 190
4.3	58732	1.30	326	40.0	--	EP315R4	200L-4	OK	PAGE 180
4.6	56092	1.09	301	30.0	EP315L3	--	200L-4	OK	PAGE 180
4.7	53989	1.82	300	45.0	--	EP316R4	200L-4	OK	PAGE 190
5.0	50159	1.52	279	40.0	--	EP315R4	200L-4	OK	PAGE 180
5.5	47263	1.44	254	30.0	EP315L3	--	200L-4	OK	PAGE 180
5.9	42539	1.82	236	40.0	--	EP315R4	200L-4	OK	PAGE 180

EP300 series gear motor

P1=30KW n1=1400 min⁻¹

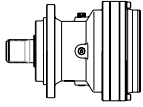
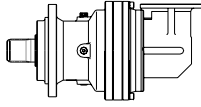
n₂ (min ⁻¹)	M₂ (N.m)	S	I 1:	P_t (KW)			IEC Motor type	Check Thermal Power Pt >= P1	Dimension Page Number
6.0	42069	2.27	234	45.0	--	EP316R4	200L-4	OK	PAGE 190
6.8	38564	1.71	207	30.0	EP315L3	--	200L-4	OK	PAGE 180
6.9	37952	1.71	204	30.0	EP316L3	--	200L-4	OK	PAGE 190
7.1	35732	2.12	198	40.0	--	EP315R4	200L-4	OK	PAGE 180
7.8	33563	1.88	180	30.0	EP315L3	--	200L-4	OK	PAGE 180
8.1	31131	2.42	173	40.0	--	EP315R4	200L-4	OK	PAGE 180
8.2	31978	1.88	172	30.0	EP316L3	--	200L-4	OK	PAGE 190
9.2	28280	2.22	152	30.0	EP315L3	--	200L-4	OK	PAGE 180
9.2	27338	2.42	152	40.0	--	EP315R4	200L-4	OK	PAGE 180
9.7	26801	3.08	144	30.0	EP316L3	--	200L-4	OK	PAGE 190
9.8	26691	1.17	143	40.0	--	EP313R3	200L-4	OK	PAGE 170
11.0	23701	2.74	127	30.0	EP315L3	--	200L-4	OK	PAGE 180
11.3	23166	2.56	124	75.0	--	EP315R3	200L-4	OK	PAGE 180
11.3	23059	1.03	124	40.0	--	EP311R3	200L-4	OK	PAGE 160
11.5	22582	3.42	121	30.0	EP316L3	--	200L-4	OK	PAGE 190
11.6	22510	1.32	121	40.0	--	EP313R3	200L-4	OK	PAGE 170
12.9	20242	3.08	109	30.0	EP315L3	--	200L-4	OK	PAGE 180
13.4	19520	3.08	105	75.0	--	EP315R3	200L-4	OK	PAGE 180
13.4	19429	1.17	104	40.0	--	EP311R3	200L-4	OK	PAGE 160
13.7	18967	1.47	102	40.0	--	EP313R3	200L-4	OK	PAGE 170
13.8	18926	3.42	102	30.0	EP316L3	--	200L-4	OK	PAGE 190
15.2	17166	3.42	92.2	30.0	EP315L3	--	200L-4	OK	PAGE 180
16.0	16284	1.32	87.5	40.0	--	EP311R3	200L-4	OK	PAGE 160
16.4	15896	1.76	85.4	40.0	--	EP313R3	200L-4	OK	PAGE 170
17.7	14747	3.42	79	30.0	EP316L3	--	200L-4	OK	PAGE 190
18.1	14420	3.42	77.4	30.0	EP315L3	--	200L-4	OK	PAGE 180
20.5	12689	1.47	68.1	40.0	--	EP311R3	200L-4	OK	PAGE 160
20.8	12563	3.42	67.5	30.0	EP315L3	--	200L-4	OK	PAGE 180
21.0	12407	1.76	66.6	40.0	--	EP313R3	200L-4	OK	PAGE 170
22.7	11492	3.42	62	30.0	EP316L3	--	200L-4	OK	PAGE 190
23.6	11032	3.42	59.2	30.0	EP315L3	--	200L-4	OK	PAGE 180
26.4	9887	1.76	53.1	40.0	--	EP311R3	200L-4	OK	PAGE 160
27.0	9667	2.05	51.9	40.0	--	EP313R3	200L-4	OK	PAGE 170
29.0	9299	1.52	48.3	22.0	EP310L2	--	200L-4	NO !	PAGE 150
33.0	8171	0.91	42.5	18.0	EP307L2	--	200L-4	NO !	PAGE 130
33.0	8171	1.19	42.5	18.0	EP309L2	--	200L-4	NO !	PAGE 140
35.5	7588	1.82	39.4	22.0	EP310L2	--	200L-4	NO !	PAGE 150
36.1	7467	2.65	38.8	25.0	EP311L2	--	200L-4	NO !	PAGE 160
39.1	6885	1.05	35.8	18.0	EP307L2	--	200L-4	NO !	PAGE 130
39.1	6885	1.62	35.8	18.0	EP309L2	--	200L-4	NO !	PAGE 140
41.6	6480	2.15	33.7	22.0	EP310L2	--	200L-4	NO !	PAGE 150
42.8	6292	2.98	32.7	25.0	EP311L2	--	200L-4	NO !	PAGE 160
43.5	5998	0.88	32.2	20.0	--	EP307R3	200L-4	NO !	PAGE 130
47.9	5626	1.28	29.3	18.0	EP307L2	--	200L-4	NO !	PAGE 130
47.9	5626	1.70	29.3	18.0	EP309L2	--	200L-4	NO !	PAGE 140
48.4	5564	2.32	28.9	22.0	EP310L2	--	200L-4	NO !	PAGE 150
50.8	5301	3.31	27.6	25.0	EP311L2	--	200L-4	NO !	PAGE 160
53.3	5049	1.42	26.3	18.0	EP307L2	--	200L-4	NO !	PAGE 130
53.3	5049	1.70	26.3	18.0	EP309L2	--	200L-4	NO !	PAGE 140
56.7	4752	2.48	24.7	22.0	EP310L2	--	200L-4	NO !	PAGE 150
59.4	4537	1.19	23.6	35.0	--	EP307R2	200L-4	OK	PAGE 130

EP300 series gear motor

P1=30KW n1=1400 min⁻¹

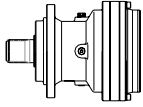
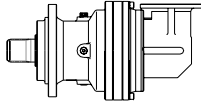
n ₂ (min ⁻¹)	M ₂ (N.m)	S	I 1:	P _t (KW)			IEC Motor type	Check Thermal	Dimension
								Power Pt >= P1	Page Number
59.4	4537	1.28	23.6	35.0	--	EP309R2	200L-4	OK	PAGE 140
60.6	4443	3.31	23.1	25.0	EP311L2	--	200L-4	NO !	PAGE 160
63.6	4232	1.56	22.0	18.0	EP307L2	--	200L-4	NO !	PAGE 130
63.6	4232	1.70	22.0	18.0	EP309L2	--	200L-4	NO !	PAGE 140
66.8	4030	2.65	21.0	22.0	EP310L2	--	200L-4	NO !	PAGE 150
70.4	3823	1.28	19.9	35.0	--	EP307R2	200L-4	OK	PAGE 130
70.4	3823	1.28	19.9	35.0	--	EP309R2	200L-4	OK	PAGE 140
75.8	3555	1.70	18.5	18.0	EP307L2	--	200L-4	NO !	PAGE 130
75.8	3555	1.70	18.5	18.0	EP309L2	--	200L-4	NO !	PAGE 140
77.8	3462	3.31	18.0	25.0	EP311L2	--	200L-4	NO !	PAGE 160
79.5	3385	2.98	17.6	22.0	EP310L2	--	200L-4	NO !	PAGE 150
84.0	3204	1.42	16.7	35.0	--	EP307R2	200L-4	OK	PAGE 130
84.0	3204	1.42	16.7	35.0	--	EP309R2	200L-4	OK	PAGE 140
86.8	3103	1.70	16.1	18.0	EP307L2	--	200L-4	NO !	PAGE 130
86.8	3103	1.70	16.1	18.0	EP307L2	--	200L-4	NO !	PAGE 130
86.8	3103	1.70	16.1	18.0	EP309L2	--	200L-4	NO !	PAGE 140
99.8	2698	3.31	14.0	25.0	EP311L2	--	200L-4	NO !	PAGE 160
108	2497	1.70	13.0	35.0	--	EP307R2	200L-4	OK	PAGE 130
108	2497	1.70	13.0	35.0	--	EP307R2	200L-4	OK	PAGE 130
108	2497	1.70	13.0	35.0	--	EP307R2	200L-4	OK	PAGE 130
108	2497	1.70	13.0	35.0	--	EP307R2	200L-4	OK	PAGE 130
108	2497	1.70	13.0	35.0	--	EP309R2	200L-4	OK	PAGE 140
111	2418	1.70	12.6	18.0	EP307L2	--	200L-4	NO !	PAGE 130
111	2418	1.70	12.6	18.0	EP309L2	--	200L-4	NO !	PAGE 140
225	1237	3.21	6.2	22.0	EP307L1	--	200L-4	NO !	PAGE 130
267	1042	3.21	5.3	22.0	EP307L1	--	200L-4	NO !	PAGE 130
318	873	3.21	4.4	22.0	EP307L1	--	200L-4	NO !	PAGE 130
408	681	3.21	3.4	22.0	EP307L1	--	200L-4	NO !	PAGE 130

EP300 series gear motor

P1=37KW n1=1400 min⁻¹

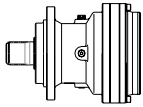
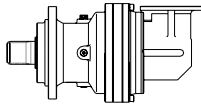
n ₂ (min ⁻¹)	M ₂ (N.m)	S	I 1:	P _t (KW)			IEC Motor type	Check Thermal	Dimension
								Power Pt >= P1	Page Number
2.6	121008	0.98	545	45.0	--	EP316R4	225S-4	OK	PAGE 190
3.0	101961	1.11	459	45.0	--	EP316R4	225S-4	OK	PAGE 190
3.6	85453	1.28	385	45.0	--	EP316R4	225S-4	OK	PAGE 190
4.3	72437	1.06	326	40.0	--	EP315R4	225S-4	OK	PAGE 180
4.6	69181	0.89	301	30.0	EP315L3	--	225S-4	NO !	PAGE 180
4.7	66587	1.47	300	45.0	--	EP316R4	225S-4	OK	PAGE 190
5.0	61863	1.23	279	40.0	--	EP315R4	225S-4	OK	PAGE 180
5.5	58291	1.16	254	30.0	EP315L3	--	225S-4	NO !	PAGE 180
5.9	52464	1.47	236	40.0	--	EP315R4	225S-4	OK	PAGE 180
6.0	51886	1.84	234	45.0	--	EP316R4	225S-4	OK	PAGE 190
6.8	47562	1.39	207	30.0	EP315L3	--	225S-4	NO !	PAGE 180
6.9	46808	1.39	204	30.0	EP316L3	--	225S-4	NO !	PAGE 190
7.1	44070	1.72	198	40.0	--	EP315R4	225S-4	OK	PAGE 180
7.8	41394	1.52	180	30.0	EP315L3	--	225S-4	NO !	PAGE 180

EP300 series gear motor

P1=37KW n1=1400 min⁻¹

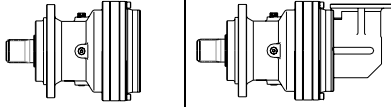
n ₂ (min ⁻¹)	M ₂ (N.m)	S	I 1:	P _t (KW)			IEC Motor type	Check Thermal Power Pt >= P1	Dimension Page Number
8.1	38394	1.97	173	40.0	--	EP315R4	225S-4	OK	PAGE 180
8.2	39440	1.52	172	30.0	EP316L3	--	225S-4	NO !	PAGE 190
9.2	34879	1.80	152	30.0	EP315L3	--	225S-4	NO !	PAGE 180
9.2	33717	1.97	152	40.0	--	EP315R4	225S-4	OK	PAGE 180
9.7	33054	2.49	144	30.0	EP316L3	--	225S-4	NO !	PAGE 190
9.8	32919	0.95	143	40.0	--	EP313R3	225S-4	OK	PAGE 170
11.0	29232	2.22	127	30.0	EP315L3	--	225S-4	NO !	PAGE 180
11.3	28572	2.08	124	75.0	--	EP315R3	225S-4	OK	PAGE 180
11.5	27851	2.77	121	30.0	EP316L3	--	225S-4	NO !	PAGE 190
11.6	27762	1.07	121	40.0	--	EP313R3	225S-4	OK	PAGE 170
12.9	24965	2.49	109	30.0	EP315L3	--	225S-4	NO !	PAGE 180
13.4	24074	2.49	105	75.0	--	EP315R3	225S-4	OK	PAGE 180
13.4	23963	0.95	104	40.0	--	EP311R3	225S-4	OK	PAGE 160
13.7	23392	1.19	102	40.0	--	EP313R3	225S-4	OK	PAGE 170
13.8	23342	2.77	102	30.0	EP316L3	--	225S-4	NO !	PAGE 190
15.2	21172	2.77	92.2	30.0	EP315L3	--	225S-4	NO !	PAGE 180
15.3	20953	2.77	91.2	75.0	--	EP315R3	225S-4	OK	PAGE 180
16.0	20083	1.07	87.5	40.0	--	EP311R3	225S-4	OK	PAGE 160
16.4	19605	1.43	85.4	40.0	--	EP313R3	225S-4	OK	PAGE 170
17.7	18189	2.77	79	30.0	EP316L3	--	225S-4	NO !	PAGE 190
18.1	17784	2.77	77.4	30.0	EP315L3	--	225S-4	NO !	PAGE 180
20.5	15649	1.19	68.1	40.0	--	EP311R3	225S-4	OK	PAGE 160
20.8	15494	2.77	67.5	30.0	EP315L3	--	225S-4	NO !	PAGE 180
21.0	15301	1.43	66.6	40.0	--	EP313R3	225S-4	OK	PAGE 170
22.7	14173	2.77	62	30.0	EP316L3	--	225S-4	NO !	PAGE 190
23.6	13607	2.77	59.2	30.0	EP315L3	--	225S-4	NO !	PAGE 180
26.4	12194	1.43	53.1	40.0	--	EP311R3	225S-4	OK	PAGE 160
26.6	12106	2.77	53	90.0	--	EP316R3	225S-4	OK	PAGE 190
27.0	11923	1.66	51.9	40.0	--	EP313R3	225S-4	OK	PAGE 170
37.0	8982	2.95	37.9	30.0	EP313L2	--	225S-4	NO !	PAGE 170
43.8	7575	3.22	31.9	30.0	EP313L2	--	225S-4	NO !	PAGE 170
52.0	6383	3.49	26.9	30.0	EP313L2	--	225S-4	NO !	PAGE 170
59.4	5596	0.97	23.6	35.0	--	EP307R2	225S-4	NO !	PAGE 130
62.1	5349	3.49	22.6	30.0	EP313L2	--	225S-4	NO !	PAGE 170
70.1	4737	3.49	20.0	55.0	--	EP310R2	225S-4	OK	PAGE 150
70.4	4715	1.04	19.9	35.0	--	EP307R2	225S-4	NO !	PAGE 130
70.4	4715	1.04	19.9	35.0	--	EP309R2	225S-4	NO !	PAGE 140
79.5	4175	3.49	17.6	30.0	EP313L2	--	225S-4	NO !	PAGE 170
84.0	3951	1.15	16.7	35.0	--	EP307R2	225S-4	NO !	PAGE 130
84.0	3951	1.15	16.7	35.0	--	EP309R2	225S-4	NO !	PAGE 140
95.6	3474	3.49	14.6	55.0	--	EP310R2	225S-4	OK	PAGE 150
102	3253	3.49	13.7	30.0	EP313L2	--	225S-4	NO !	PAGE 170
108	3079	1.38	13.0	35.0	--	EP307R2	225S-4	NO !	PAGE 130
108	3079	1.38	13.0	35.0	--	EP307R2	225S-4	NO !	PAGE 130
108	3079	1.38	13.0	35.0	--	EP307R2	225S-4	NO !	PAGE 130
108	3079	1.38	13.0	35.0	--	EP307R2	225S-4	NO !	PAGE 130
108	3079	1.38	13.0	35.0	--	EP309R2	225S-4	NO !	PAGE 140
114	2918	3.49	12.3	55.0	--	EP310R2	225S-4	OK	PAGE 150
225	1525	3.38	6.2	25.0	EP309L1	--	225S-4	NO !	PAGE 140
267	1285	3.38	5.3	25.0	EP309L1	--	225S-4	NO !	PAGE 140
318	1077	3.38	4.4	25.0	EP309L1	--	225S-4	NO !	PAGE 140

EP300 series gear motor

P1=45KW n1=1400 min⁻¹

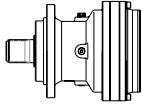
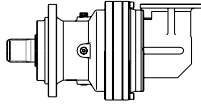
n ₂ (min ⁻¹)	M ₂ (N.m)	S	I 1:	P _t (KW)			IEC Motor type	Check Thermal	Dimension
								Power Pt >= P1	Page Number
3.0	124006	0.91	459	45.0	--	EP316R4	225M-4	OK	PAGE 190
3.6	103929	1.05	385	45.0	--	EP316R4	225M-4	OK	PAGE 190
4.7	80984	1.21	300	45.0	--	EP316R4	225M-4	OK	PAGE 190
5.9	63808	1.21	236	40.0	--	EP315R4	225M-4	NO !	PAGE 180
6.0	63104	1.52	234	45.0	--	EP316R4	225M-4	OK	PAGE 190
7.1	53599	1.41	198	40.0	--	EP315R4	225M-4	NO !	PAGE 180
8.1	46696	1.62	173	40.0	--	EP315R4	225M-4	NO !	PAGE 180
9.2	41007	1.62	152	40.0	--	EP315R4	225M-4	NO !	PAGE 180
11.3	34750	1.71	124	75.0	--	EP315R3	225M-4	OK	PAGE 180
11.6	33765	0.88	121	40.0	--	EP313R3	225M-4	NO !	PAGE 170
13.4	29280	2.05	105	75.0	--	EP315R3	225M-4	OK	PAGE 180
13.7	28450	0.98	102	40.0	--	EP313R3	225M-4	NO !	PAGE 170
14.6	26757	2.96	96	90.0	--	EP316R3	225M-4	OK	PAGE 190
15.3	25483	2.28	91.2	75.0	--	EP315R3	225M-4	OK	PAGE 180
16.4	23844	1.17	85.4	40.0	--	EP313R3	225M-4	NO !	PAGE 170
17.3	22545	3.42	81	90.0	--	EP316R3	225M-4	OK	PAGE 190
18.2	21472	2.85	76.9	75.0	--	EP315R3	225M-4	OK	PAGE 180
20.7	18895	3.42	68	90.0	--	EP316R3	225M-4	OK	PAGE 190
21.0	18610	1.17	66.6	40.0	--	EP313R3	225M-4	NO !	PAGE 170
21.7	17995	3.42	64.4	75.0	--	EP315R3	225M-4	OK	PAGE 180
25.9	15116	3.42	54.1	75.0	--	EP315R3	225M-4	OK	PAGE 180
26.4	14831	1.17	53.1	40.0	--	EP311R3	225M-4	NO !	PAGE 160
26.6	14724	2.28	53	90.0	--	EP316R3	225M-4	OK	PAGE 190
27.0	14501	1.37	51.9	40.0	--	EP313R3	225M-4	NO !	PAGE 170
29.7	13169	3.42	47.2	75.0	--	EP315R3	225M-4	OK	PAGE 180
70.1	5761	2.87	20.0	55.0	--	EP310R2	225M-4	OK	PAGE 150
73.5	5492	3.31	19.0	75.0	--	EP313R2	225M-4	OK	PAGE 170
76.7	5265	3.31	18.2	75.0	--	EP311R2	225M-4	OK	PAGE 160
83.7	4828	3.31	16.7	75.0	--	EP313R2	225M-4	OK	PAGE 170
91.1	4436	3.31	15.4	75.0	--	EP311R2	225M-4	OK	PAGE 160
95.6	4225	2.87	14.6	55.0	--	EP310R2	225M-4	OK	PAGE 150
114	3549	2.87	12.3	55.0	--	EP310R2	225M-4	OK	PAGE 150
117	3457	3.31	12.0	75.0	--	EP311R2	225M-4	OK	PAGE 160
120	3380	3.31	11.7	75.0	--	EP313R2	225M-4	OK	PAGE 170

P1=55KW n1=1400 min⁻¹

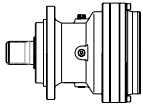
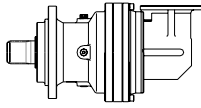
n ₂ (min ⁻¹)	M ₂ (N.m)	S	I 1:	P _t (KW)			IEC Motor type	Check Thermal	Dimension
								Power Pt >= P1	Page Number
11.3	42472	1.40	124	75.0	--	EP315R3	250M-4	OK	PAGE 180
13.4	35786	1.68	105	75.0	--	EP315R3	250M-4	OK	PAGE 180
14.6	32703	2.42	96	90.0	--	EP316R3	250M-4	OK	PAGE 190
15.3	31146	1.86	91.2	75.0	--	EP315R3	250M-4	OK	PAGE 180
17.3	27556	2.80	81	90.0	--	EP316R3	250M-4	OK	PAGE 190
18.2	26243	2.33	76.9	75.0	--	EP315R3	250M-4	OK	PAGE 180
20.7	23094	2.80	68	90.0	--	EP316R3	250M-4	OK	PAGE 190
21.7	21994	2.80	64.4	75.0	--	EP315R3	250M-4	OK	PAGE 180
25.9	18475	2.80	54.1	75.0	--	EP315R3	250M-4	OK	PAGE 180

EP300 series gear motor

P1=55KW n1=1400 min⁻¹

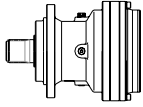
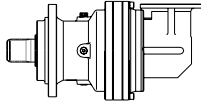
n₂ (min ⁻¹)	M₂ (N.m)	S	I 1:	P_t (KW)			IEC Motor type	Check Thermal Power Pt >= P1	Dimension Page Number
26.6	17995	1.86	53	90.0	--	EP316R3	250M-4	OK	PAGE 190
29.7	16096	2.80	47.2	75.0	--	EP315R3	250M-4	OK	PAGE 180
70.1	7041	2.35	20.0	55.0	--	EP310R2	250M-4	OK	PAGE 150
73.5	6713	2.71	19.0	75.0	--	EP313R2	250M-4	OK	PAGE 170
76.7	6435	2.71	18.2	75.0	--	EP311R2	250M-4	OK	PAGE 160
83.7	5901	2.71	16.7	75.0	--	EP313R2	250M-4	OK	PAGE 170
91.1	5422	2.71	15.4	75.0	--	EP311R2	250M-4	OK	PAGE 160
95.6	5164	2.35	14.6	55.0	--	EP310R2	250M-4	OK	PAGE 150
114	4337	2.35	12.3	55.0	--	EP310R2	250M-4	OK	PAGE 150
117	4225	2.71	12.0	75.0	--	EP311R2	250M-4	OK	PAGE 160
120	4131	2.71	11.7	75.0	--	EP313R2	250M-4	OK	PAGE 170

EP300 series gear motor

P1=75KW n1=1400 min⁻¹

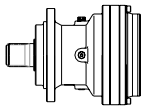
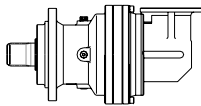
n₂ (min ⁻¹)	M₂ (N.m)	S	I 1:	P_t (KW)			IEC Motor type	Check Thermal Power Pt >= P1	Dimension Page Number
11.3	57916	1.03	124	75.0	--	EP315R3	280S-4	OK	PAGE 180
13.4	48800	1.23	105	75.0	--	EP315R3	280S-4	OK	PAGE 180
14.6	44595	1.78	96	90.0	--	EP316R3	280S-4	OK	PAGE 190
15.3	42472	1.37	91.2	75.0	--	EP315R3	280S-4	OK	PAGE 180
17.3	37576	2.05	81	90.0	--	EP316R3	280S-4	OK	PAGE 190
18.2	35786	1.71	76.9	75.0	--	EP315R3	280S-4	OK	PAGE 180
20.7	31492	2.05	68	90.0	--	EP316R3	280S-4	OK	PAGE 190
21.7	29992	2.05	64.4	75.0	--	EP315R3	280S-4	OK	PAGE 180
25.9	25194	2.05	54.1	75.0	--	EP315R3	280S-4	OK	PAGE 180
26.6	24539	1.37	53	90.0	--	EP316R3	280S-4	OK	PAGE 190
29.7	21949	2.05	47.2	75.0	--	EP315R3	280S-4	OK	PAGE 180
73.5	9154	1.99	19.0	75.0	--	EP313R2	280S-4	OK	PAGE 170
76.7	8774	1.99	18.2	75.0	--	EP311R2	280S-4	OK	PAGE 160
83.7	8047	1.99	16.7	75.0	--	EP313R2	280S-4	OK	PAGE 170
91.1	7393	1.99	15.4	75.0	--	EP311R2	280S-4	OK	PAGE 160
117	5761	1.99	12.0	75.0	--	EP311R2	280S-4	OK	PAGE 160
120	5633	1.99	11.7	75.0	--	EP313R2	280S-4	OK	PAGE 170

EP300 series gear motor

P1=90KW n1=1400 min⁻¹

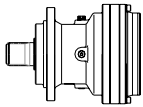
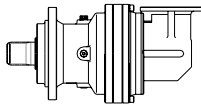
n₂ (min ⁻¹)	M₂ (N.m)	S	I 1:	P_t (KW)			IEC Motor type	Check Thermal Power Pt >= P1	Dimension Page Number
14.6	53514	1.48	96	90.0	--	EP316R3	280M-4	OK	PAGE 190
17.3	45091	1.71	81	90.0	--	EP316R3	280M-4	OK	PAGE 190
20.7	37790	1.71	68	90.0	--	EP316R3	280M-4	OK	PAGE 190
26.6	29447	1.14	53	90.0	--	EP316R3	280M-4	OK	PAGE 190
73.5	10984	1.65	19.0	75.0	--	EP313R2	280M-4	NO !	PAGE 170
83.7	9656	1.65	16.7	75.0	--	EP313R2	280M-4	NO !	PAGE 170
120	6760	1.65	11.7	75.0	--	EP313R2	280M-4	NO !	PAGE 170

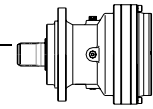

EP300L

M2'=1000N.m

	I 1:	Mn ₂ (N.m)						P ₁ (KW)	P _t (KW) (ta=20°C) (n ₁ =1500)	n ₁ (min ⁻¹)	n _{1max} (min ⁻¹)	M _b (N.m)	Brake type	
		n ₂ .h 10000	n ₂ .h 25000	n ₂ .h 50000	n ₂ .h 100000	n ₂ .h 500000	n ₂ .h 1000000							
L1	3.4	1 000	1 000	890	850	760	610	20	7.5	1 750	3 500	400	4K	
	4.4	1 000	1 000	890	850	760	610	20	7.5	1 750	3 500	330	4H	
	5.8	860	730	650	650	650	580	15	7.5	1 750	3 500	260	4F	
	7.2	700	600	550	550	550	510	11	7.5	1 750	3 500	160	4D	
L2	11.5	1 000	1 000	890	850	760	610	9	7.5	1 750	3 500	100	4B	
	15	1 000	1 000	890	850	760	610	7.5	7.5	1 750	3 500	100	4B	
	19.8	1 000	1 000	890	850	760	610	6.2	7.5	1 750	3 500	100	4B	
	25.6	1 000	1 000	890	850	760	610	5	7.5	1 750	3 500	100	4B	
	32	1 000	1 000	890	850	760	610	4.1	7.5	1 750	3 500	50	4A	
	41.5	860	730	650	650	650	580	2.8	7.5	1 750	3 500	50	4A	
	51.8	700	600	550	550	550	510	1.9	7.5	1 750	3 500	50	4A	
	L3	38.8	1 000	1 000	890	850	760	610	3.5	7.5	1 750	3 500	50	4A
		50.9	1 000	1 000	890	850	760	610	2.8	7.5	1 750	3 500	50	4A
66.1		1 000	1 000	890	850	760	610	2.2	7.5	1 750	3 500	50	4A	
87.8		1 000	1 000	890	850	760	610	1.7	7.5	1 750	3 500	50	4A	
108		1 000	1 000	890	850	760	610	1.4	7.5	1 750	3 500	50	4A	
114		1 000	1 000	890	850	760	610	1.3	7.5	1 750	3 500	50	4A	
142		1 000	1 000	890	850	760	610	1.1	7.5	1 750	3 500	50	4A	
185		1 000	1 000	890	850	760	610	0.85	7.5	1 750	3 500	50	4A	
230		1 000	1 000	890	850	760	610	0.7	7.5	1 750	3 500	50	4A	
299		860	730	650	650	650	580	0.38	7.5	1 750	3 500	50	4A	
373	700	600	550	550	550	510	0.27	7.5	1 750	3 500	50	4A		
L4	297	1 000	1 000	890	850	760	610	0.54	6.0	1 750	3 500	50	4A	
	386	1 000	1 000	890	850	760	610	0.42	6.0	1 750	3 500	50	4A	
	476	1 000	1 000	890	850	760	610	0.35	6.0	1 750	3 500	50	4A	
	501	1 000	1 000	890	850	760	610	0.33	6.0	1 750	3 500	50	4A	
	625	1 000	1 000	890	850	760	610	0.27	6.0	1 750	3 500	50	4A	
	650	1 000	1 000	890	850	760	610	0.26	6.0	1 750	3 500	50	4A	
	780	1 000	1 000	890	850	760	610	0.23	6.0	1 750	3 500	50	4A	
	853	1 000	1 000	890	850	760	610	0.21	6.0	1 750	3 500	50	4A	
	1024	1 000	1 000	890	850	760	610	0.17	6.0	1 750	3 500	50	4A	
	1108	860	730	650	650	650	580	0.12	6.0	1 750	3 500	50	4A	
	1329	1 000	1 000	890	850	760	610	0.13	6.0	1 750	3 500	50	4A	
	1383	860	730	650	650	650	580	0.11	6.0	1 750	3 500	50	4A	
	1659	1 000	1 000	890	850	760	610	0.11	6.0	1 750	3 500	50	4A	
	1725	860	730	650	650	650	580	0.09	6.0	1 750	3 500	50	4A	
2153	860	730	650	650	650	580	0.07	6.0	1 750	3 500	50	4A		
2687	700	600	550	550	550	510	0.04	6.0	1 750	3 500	50	4A		

M_{2max}=1.2×Mn₂(n₂×h=10 000)

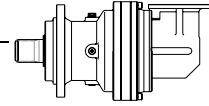

EP300R

M2'=1000N.m

	I	Mn ₂ (N.m)						P ₁ (KW)	P _t (KW) (ta=20°C) (n ₁ =1500)	n ₁ (min ⁻¹)	n _{1max} (min ⁻¹)	M _b (N.m)	Brake type
		n ₂ .h 10000	n ₂ .h 25000	n ₂ .h 50000	n ₂ .h 100000	n ₂ .h 500000	n ₂ .h 1000000						
R2	6.9	1 000	1 000	890	850	760	610	15	12	1 750	3 500	160	4D
	9.1	1 000	1 000	890	850	760	610	15	12	1 750	3 500	160	4D
	11.8	860	730	650	650	650	580	7.5	12	1 750	3 500	100	4B
	14.8	700	600	550	550	550	510	5	12	1 750	3 500	100	4B
R3	23.5	1 000	1 000	890	850	760	610	5	12	1 750	3 500	100	4B
	30.8	1 000	1 000	890	850	760	610	4.2	12	1 750	3 500	50	4A
	40.5	1 000	1 000	890	850	760	610	3.3	12	1 750	3 500	50	4A
	52.6	1 000	1 000	890	850	760	610	2.7	12	1 750	3 500	50	4A
	65.6	1 000	1 000	890	850	760	610	2.2	12	1 750	3 500	50	4A
	85.2	860	730	650	650	650	580	1.3	12	1 750	3 500	50	4A
	106	700	600	550	550	550	510	0.9	12	1 750	3 500	50	4A
R4	79.5	1 000	1 000	890	850	760	610	1.8	10	1 750	3 500	50	4A
	104	1 000	1 000	890	850	760	610	1.4	10	1 750	3 500	50	4A
	135	1 000	1 000	890	850	760	610	1.1	10	1 750	3 500	50	4A
	180	1 000	1 000	890	850	760	610	0.85	10	1 750	3 500	50	4A
	222	1 000	1 000	890	850	760	610	0.7	10	1 750	3 500	50	4A
	234	1 000	1 000	890	850	760	610	0.66	10	1 750	3 500	50	4A
	292	1 000	1 000	890	850	760	610	0.55	10	1 750	3 500	50	4A
	378	1 000	1 000	890	850	760	610	0.42	10	1 750	3 500	50	4A
	472	1 000	1 000	890	850	760	610	0.37	10	1 750	3 500	50	4A
	613	860	730	650	650	650	580	0.21	10	1 750	3 500	50	4A
	765	700	600	550	550	550	510	0.14	10	1 750	3 500	50	4A

M_{2max}=1.2×Mn2(n2×h=10 000)

EP300L

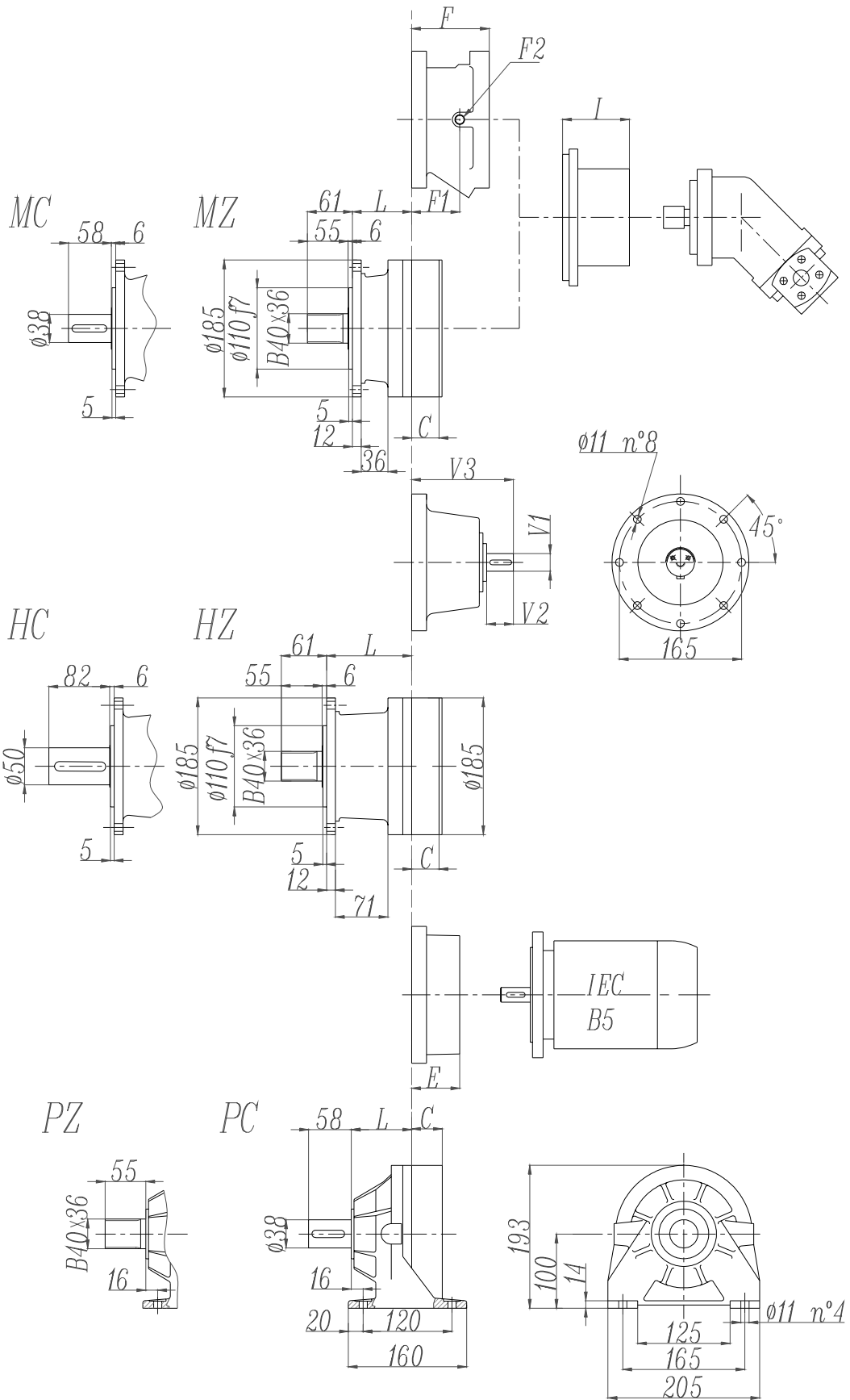

EP300L

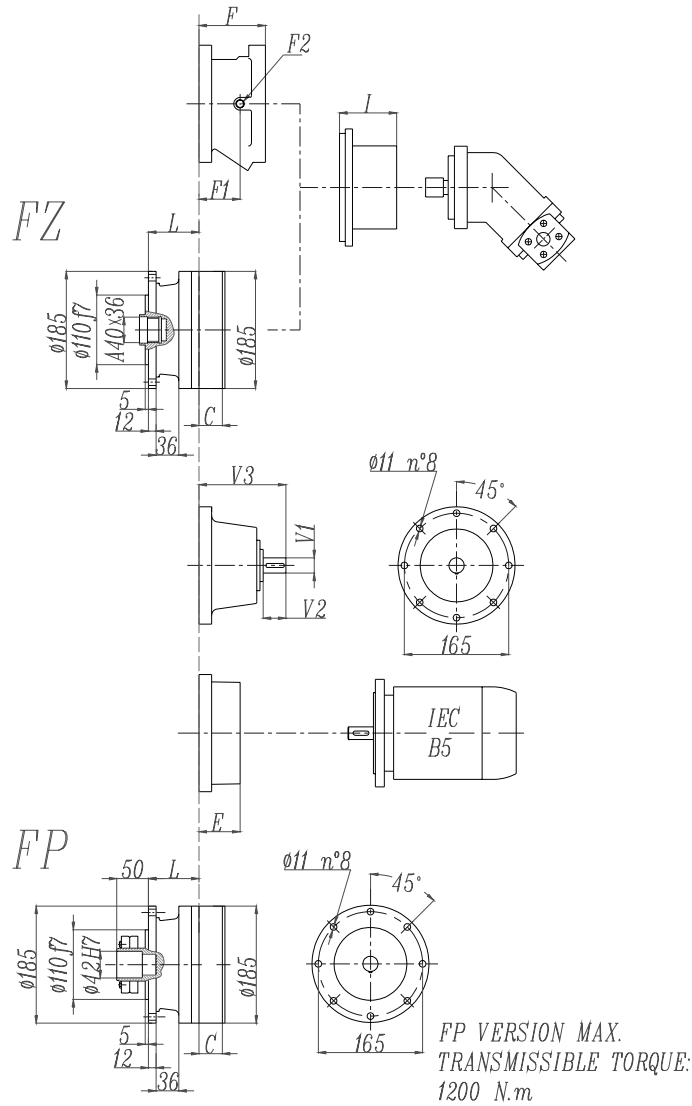

	L				Ref. weight (without input) (Kg)				C	I	Brake				Ref. Weight 15 Kg
	MZ MC	FZ FP	HZ HC	PC PZ	MZ MC	FZ FP	HZ HC	PC PZ			F	F1	F2	Type	
300L1	80	80	115	86	18	16	20	23	37	According to hydraulic motor	105	65	1/4 G	4	
300L2	133	133	168	139	22	20	24	27	37		105	65	1/4 G	4	
300L3	186	186	221	192	26	24	28	31	37		105	65	1/4 G	4	
300L4	239	239	274	245	30	28	32	35	37		105	65	1/4 G	4	

	E (IEC motor input)						
		IEC71	IEC80	IEC90	IEC100	IEC112	IEC132
300L1		65	84	84	94	94	114
300L2		65	84	84	94	94	114
300L3		65	84	84	94	94	114
300L4		65	84	84	94	94	114

EP300R

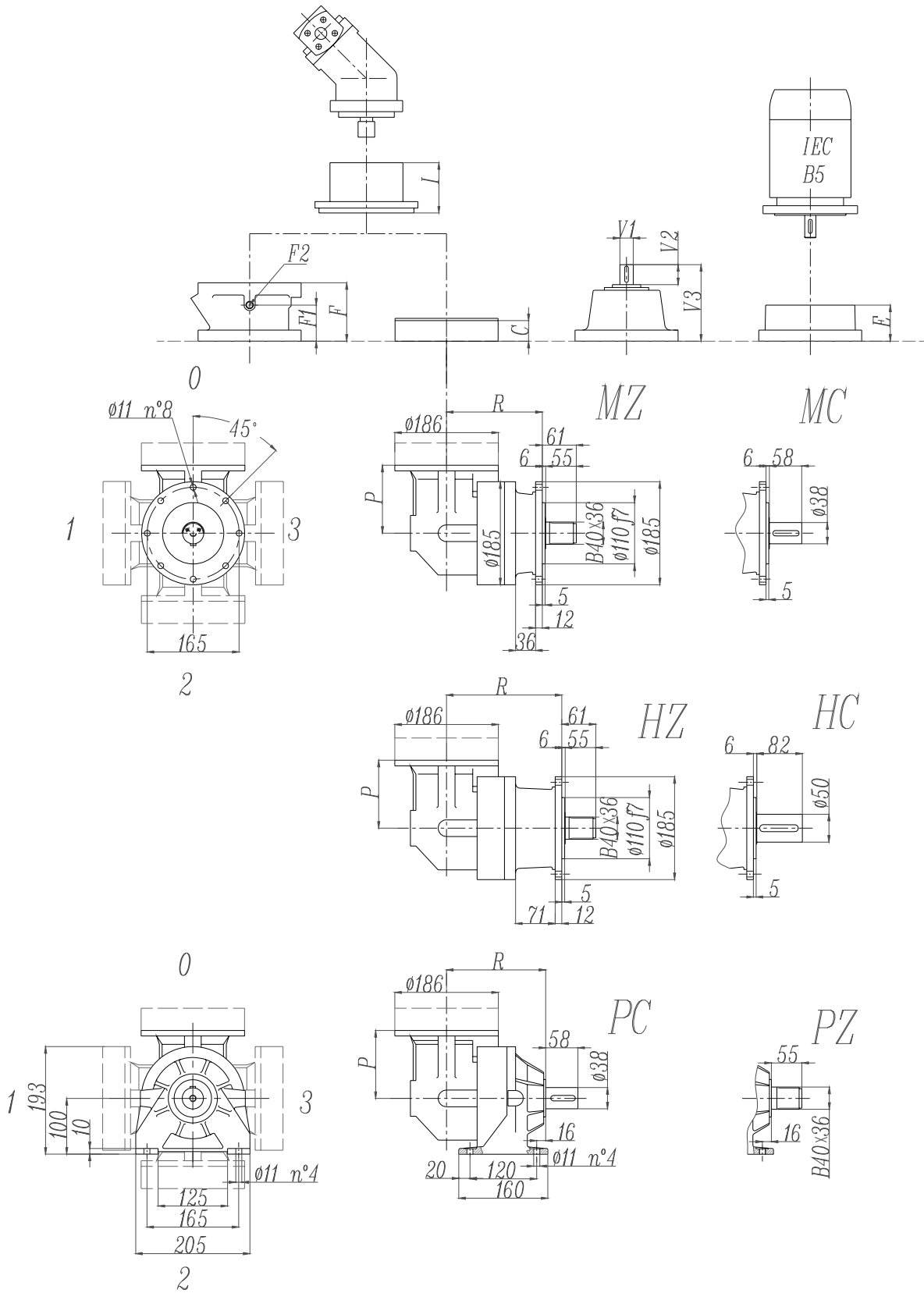

EP300R

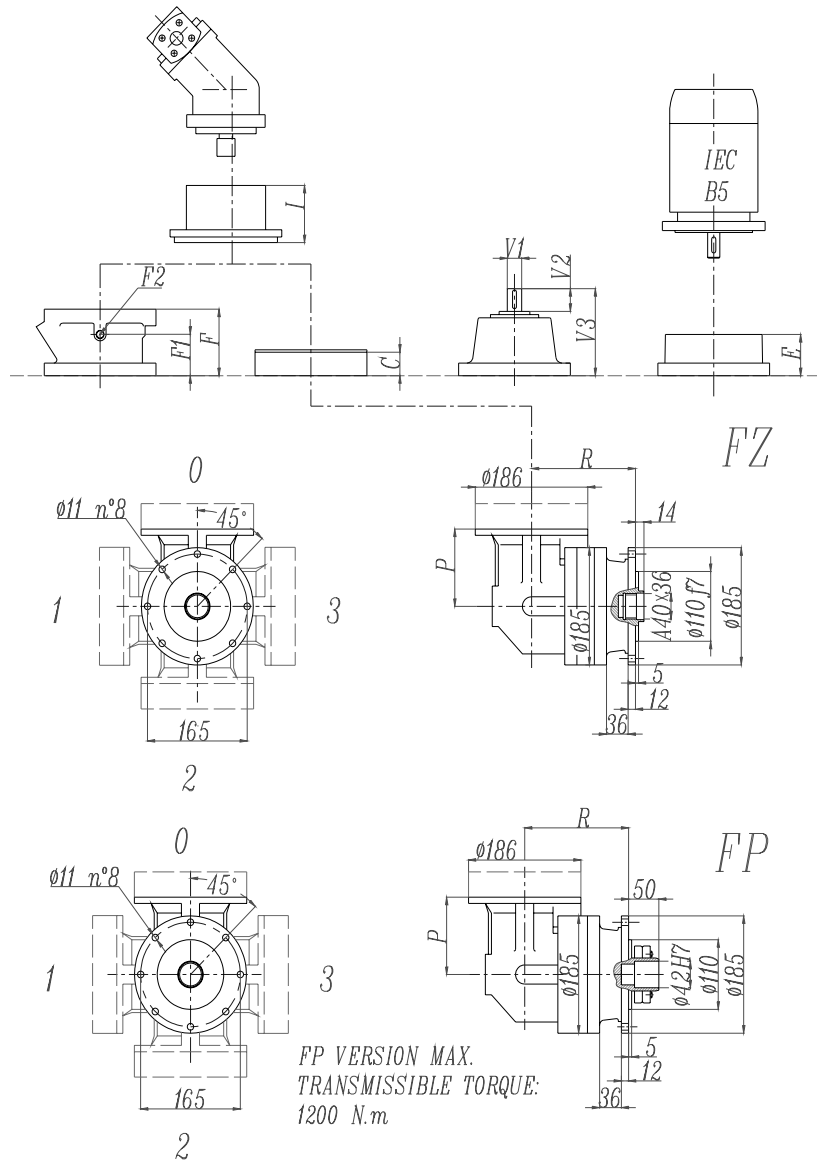

	R				Ref. weight (without input) (Kg)				C	P	I	Brake				
	MZ MC	FZ FP	HZ HC	PC PZ	MZ MC	FZ FP	HZ HC	PC PZ				F	F1	F2	Type	Ref. Weight
300R2	172	172	207	178	32	30	34	37	37	122	According to hydraulic motor	105	65	1/4 G	4	15 Kg
300R3	225	225	260	231	36	34	38	41	37			105	65	1/4 G	4	
300R4	278	278	313	284	40	38	42	45	37			105	65	1/4 G	4	

	E (IEC motor input)						
		IEC71	IEC80	IEC90	IEC100	IEC112	IEC132
300R2		65	84	84	94	94	114
300R3		65	84	84	94	94	114
300R4		65	84	84	94	94	114

EP300L - EP300R

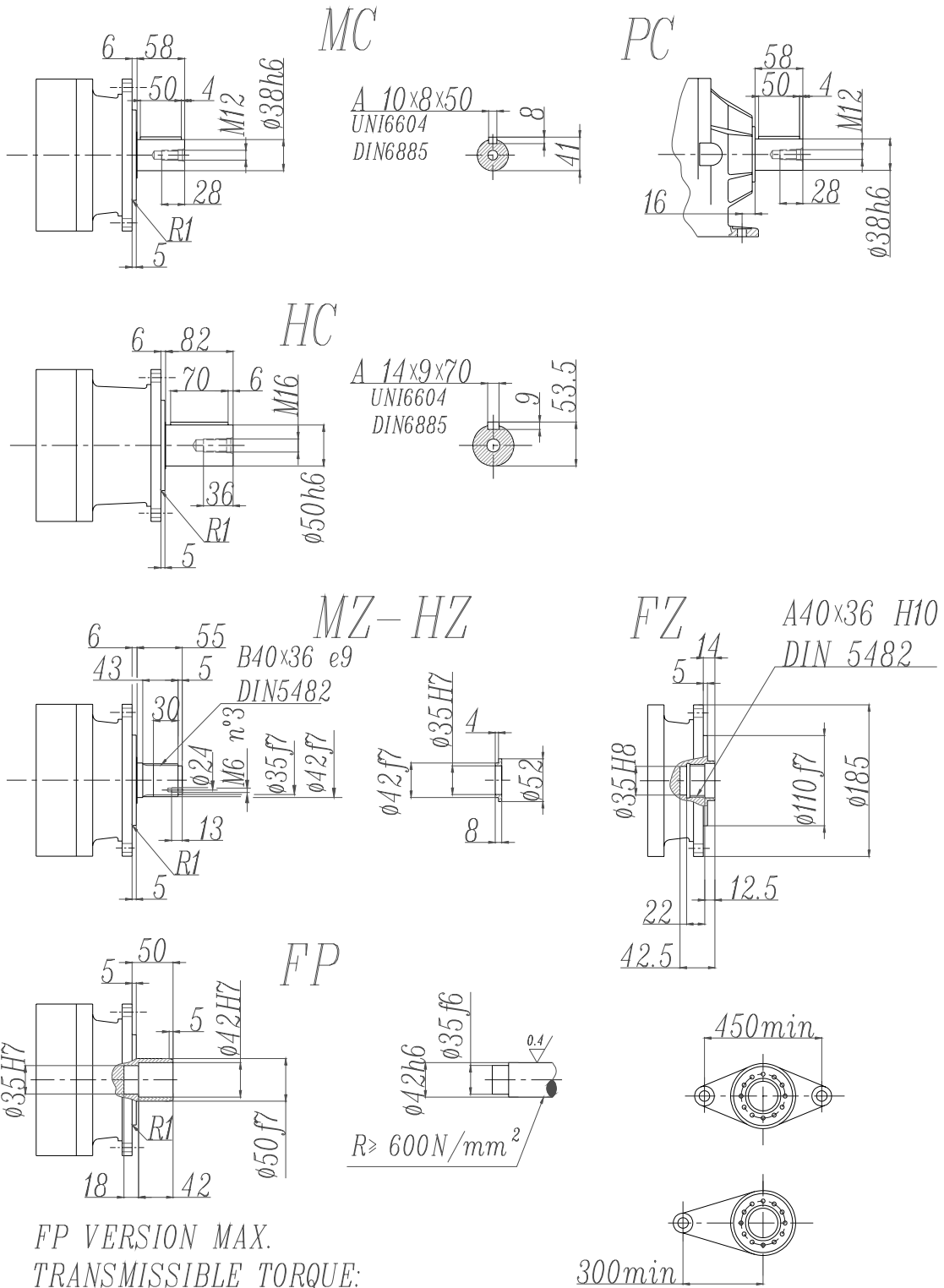

FP VERSION MAX.
 TRANSMISSIBLE TORQUE:
 1200 N.m

EP300L - EP300R

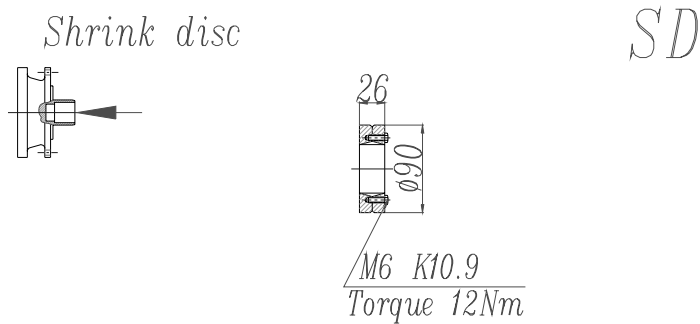
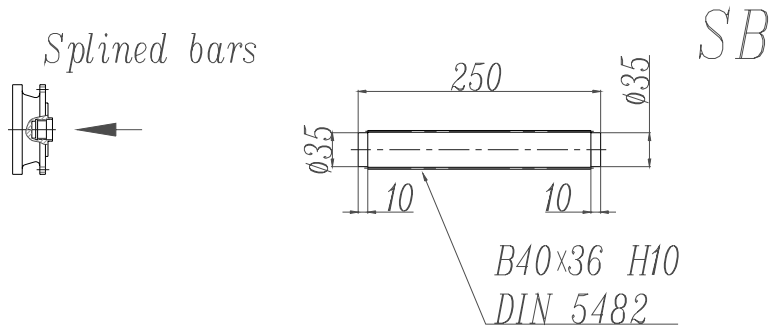
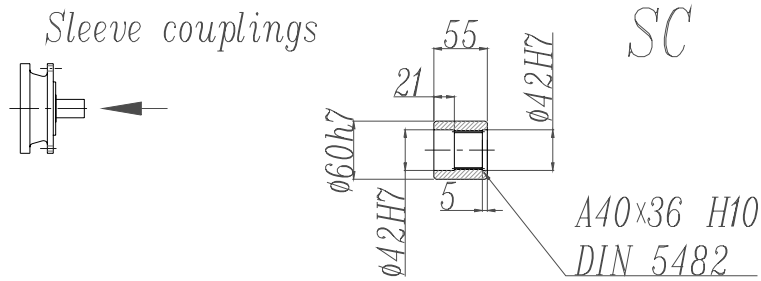
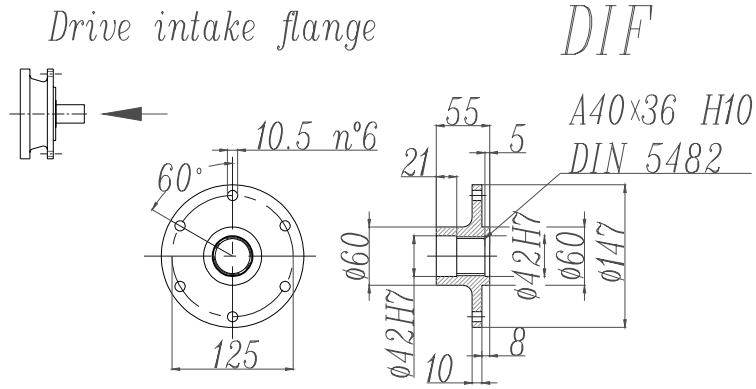

EP300L - EP300R

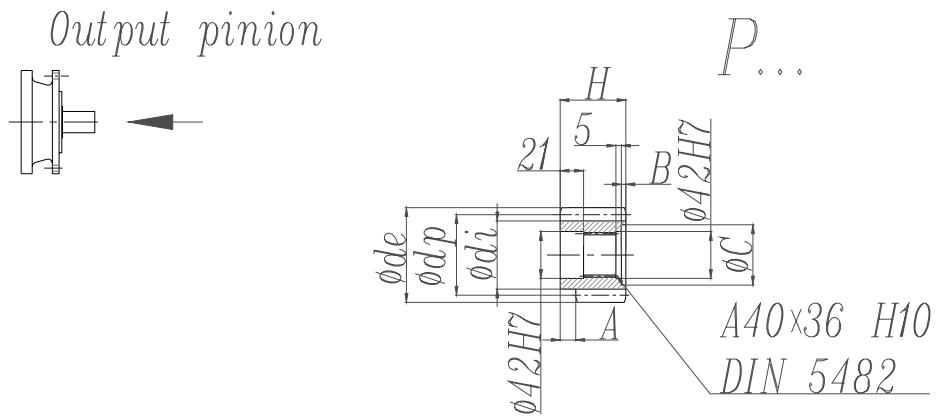

	m	z	x	dp	di	de	H	A	B	C
PBE	4.5	14	0.507	63	56	75.5	55	0	0	0
PCE	5	14	0.500	70	62.5	84.8	65	0	10	53
PDC	6	12	0.250	72	61	84.8	59	14	4	54
PDE	6	14	0.500	84	73	99.6	65	0	10	54

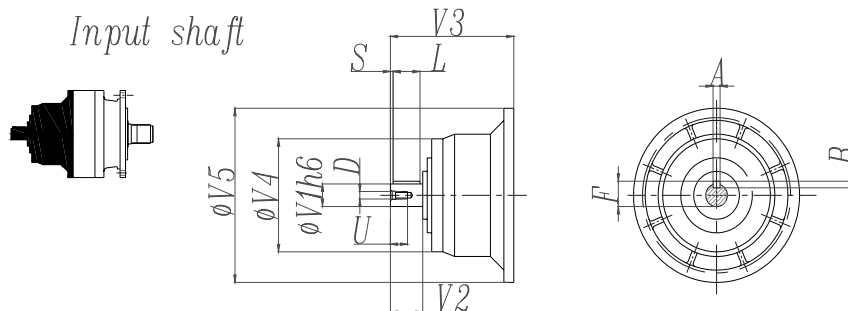

	CODE	V1	V2	V3	V4	V5	A	B	F	L	S	D	U
300L1	V01A	24	36	137.5	120	186	8	7	27	30	3	M8	19
	V01B	38	58	158	120	186	10	8	41	50	4	M12	28
300L2	V01A	24	36	137.5	120	186	8	7	27	30	3	M8	19
	V01B	38	58	158	120	186	10	8	41	50	4	M12	28
300L3	V01A	24	36	137.5	120	186	8	7	27	30	3	M8	19
	V01B	38	58	158	120	186	10	8	41	50	4	M12	28
300L4	V01A	24	36	137.5	120	186	8	7	27	30	3	M8	19
	V01B	38	58	158	120	186	10	8	41	50	4	M12	28
300R2-R3-R4	V01A	24	36	137.5	120	186	8	7	27	30	3	M8	19
	V01B	38	58	158	120	186	10	8	41	50	4	M12	28

EP300L - EP300R

Permissible radial and axial loads on output shaft with Fh2 ($n_2 \cdot h=10\ 000$)

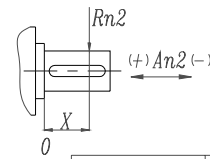
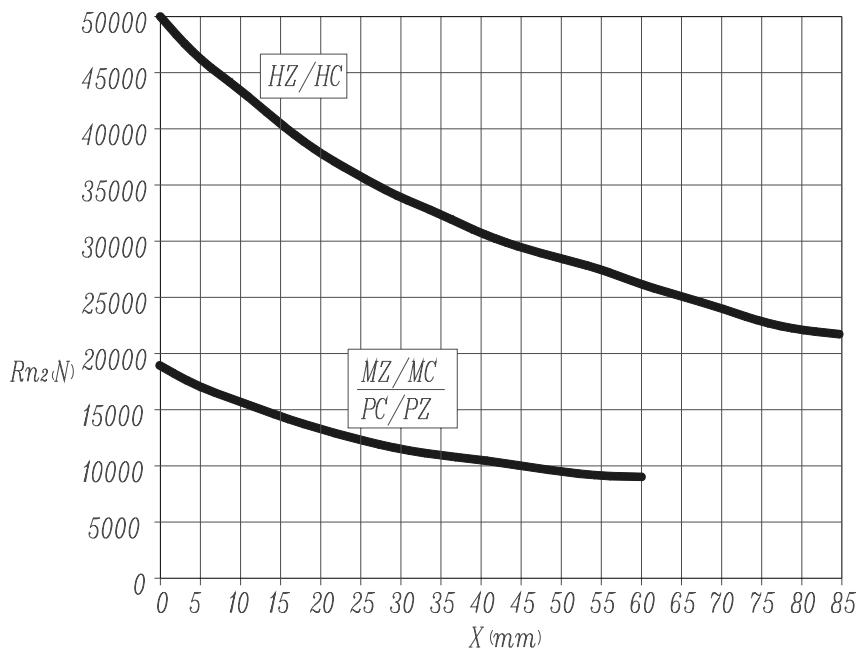

	An2 (+)	An2 (-)
MZ-MC-PC-PZ	20 000	15 000
HZ-HC	40 000	40 000

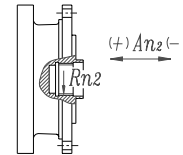

	Rn2	An2 (+/-)
FZ	8 000	8 000

Load corrective factor fh2 on shafts	fh2= n2 · h		10 000	25 000	50 000	100 000	500 000	1 000 000
	fh2	MZ-MC-PC-PZ-FZ	1	0.74	0.58	0.46	0.27	0.21
		HZ-HC	1	0.76	0.61	0.50	0.31	0.25

Permissible radial loads on input shaft with Fh1 ($n_1 \cdot h=250\ 000$)

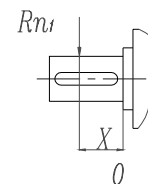
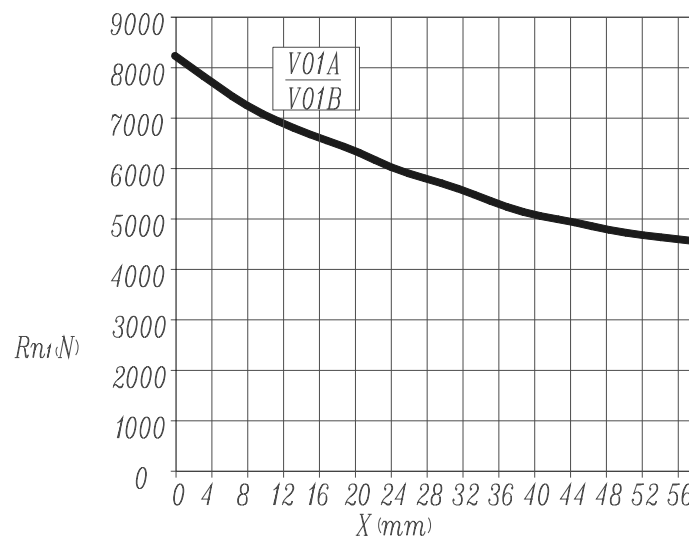

Load corrective factor fh1 on shafts	Fh1= n1 · h		250 000	500 000	1 000 000	2 00 000	5 000 000	10 000 000
	fh1		1	0.79	0.63	0.50	0.37	0.29

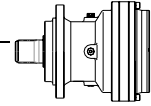

EP301L

M2'=2000N.m

	I 1:	Mn ₂ (N.m)						P ₁ (KW)	P _t (KW) (ta=20°C) (n ₁ =1500)	n ₁ (min ⁻¹)	n _{1max} (min ⁻¹)	M _b (N.m)	Brake type
		n ₂ .h 10000	n ₂ .h 25000	n ₂ .h 50000	n ₂ .h 100000	n ₂ .h 500000	n ₂ .h 1000000						
L1	3.4	2 000	2 000	1 750	1 700	1 350	1 100	30	7.5	1 750	3 500	440	4L
	4.4	2 000	2 000	1 750	1 700	1 350	1 100	30	7.5	1 750	3 500	440	4L
	5.8	1 700	1 450	1 300	1 300	1 300	1 050	28	7.5	1 750	3 500	400	4K
	7.2	1 150	1 150	1 150	1 150	1 150	940	18	7.5	1 750	3 500	260	4F
L2	11.5	2 000	2 000	1 750	1 700	1 350	1 100	15	7.5	1 750	3 500	260	4F
	15	2 000	2 000	1 750	1 700	1 350	1 100	12	7.5	1 750	3 500	260	4F
	19.8	2 000	2 000	1 750	1 700	1 350	1 100	10	7.5	1 750	3 500	160	4D
	25.6	2 000	2 000	1 750	1 700	1 350	1 100	8.2	7.5	1 750	3 500	160	4D
	32	2 000	2 000	1 750	1 700	1 350	1 100	7.5	7.5	1 750	3 500	100	4B
	41.5	1 700	1 450	1 300	1 300	1 300	1 050	5.2	7.5	1 750	3 500	100	4B
	51.8	1 150	1 150	1 150	1 150	1 150	940	3.6	7.5	1 750	3 500	50	4A
	L3	38.8	2 000	2 000	1 750	1 700	1 350	1 100	6	7.5	1 750	3 500	100
50.9		2 000	2 000	1 750	1 700	1 350	1 100	4.9	7.5	1 750	3 500	50	4A
66.1		2 000	2 000	1 750	1 700	1 350	1 100	3.8	7.5	1 750	3 500	50	4A
87.8		2 000	2 000	1 750	1 700	1 350	1 100	3	7.5	1 750	3 500	50	4A
108		2 000	2 000	1 750	1 700	1 350	1 100	2.5	7.5	1 750	3 500	50	4A
114		2 000	2 000	1 750	1 700	1 350	1 100	2.4	7.5	1 750	3 500	50	4A
142		2 000	2 000	1 750	1 700	1 350	1 100	2	7.5	1 750	3 500	50	4A
185		2 000	2 000	1 750	1 700	1 350	1 100	1.6	7.5	1 750	3 500	50	4A
230		2 000	2 000	1 750	1 700	1 350	1 100	1.3	7.5	1 750	3 500	50	4A
299		1 700	1 450	1 300	1 300	1 300	1 050	1	7.5	1 750	3 500	50	4A
373	1 150	1 150	1 150	1 150	1 150	940	0.55	7.5	1 750	3 500	50	4A	
L4	297	2 000	2 000	1 750	1 700	1 350	1 100	1	6	1 750	3 500	50	4A
	386	2 000	2 000	1 750	1 700	1 350	1 100	0.8	6	1 750	3 500	50	4A
	476	2 000	2 000	1 750	1 700	1 350	1 100	0.68	6	1 750	3 500	50	4A
	501	2 000	2 000	1 750	1 700	1 350	1 100	0.65	6	1 750	3 500	50	4A
	625	2 000	2 000	1 750	1 700	1 350	1 100	0.55	6	1 750	3 500	50	4A
	650	2 000	2 000	1 750	1 700	1 350	1 100	0.53	6	1 750	3 500	50	4A
	780	2 000	2 000	1 750	1 700	1 350	1 100	0.45	6	1 750	3 500	50	4A
	853	2 000	2 000	1 750	1 700	1 350	1 100	0.42	6	1 750	3 500	50	4A
	1024	2 000	2 000	1 750	1 700	1 350	1 100	0.35	6	1 750	3 500	50	4A
	1108	1 700	1 450	1 300	1 300	1 300	1 050	0.25	6	1 750	3 500	50	4A
	1329	2 000	2 000	1 750	1 700	1 350	1 100	0.27	6	1 750	3 500	50	4A
	1383	1 700	1 450	1 300	1 300	1 300	1 050	0.2	6	1 750	3 500	50	4A
1659	2 000	2 000	1 750	1 700	1 350	1 100	0.22	6	1 750	3 500	50	4A	
1725	1 700	1 450	1 300	1 300	1 300	1 050	0.17	6	1 750	3 500	50	4A	
2153	1 700	1 450	1 300	1 300	1 300	1 050	0.14	6	1 750	3 500	50	4A	
2687	1 150	1 150	1 150	1 150	1 150	940	0.08	6	1 750	3 500	50	4A	

M_{2max}=1.2×Mn₂(n₂×h=10 000)

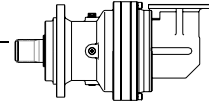

EP301R

M2'=2000N.m

	I	Mn ₂ (N.m)						P ₁	P _t (KW) (ta=20°C) (n ₁ =1500)	n ₁	n _{1max}	M _b	Brake type
		n ₂ .h 10000	n ₂ .h 25000	n ₂ .h 50000	n ₂ .h 100000	n ₂ .h 500000	n ₂ .h 1000000						
R2	6.9	1 200	1 200	1 200	1 200	1 100	930	15	12	1 750	3 500	260	4F
	9.1	1 450	1 450	1 450	1 450	1 250	1 050	15	12	1 750	3 500	260	4F
	11.8	1 700	1 450	1 300	1 300	1 300	1 050	14	12	1 750	3 500	260	4F
	14.8	1 150	1 150	1 150	1 150	1 150	940	11	12	1 750	3 500	160	4D
R3	23.5	2 000	2 000	1 750	1 700	1 350	1 100	8	12	1 750	3 500	160	4D
	30.8	2 000	2 000	1 750	1 700	1 350	1 100	7.7	12	1 750	3 500	100	4B
	40.5	2 000	2 000	1 750	1 700	1 350	1 100	6.3	12	1 750	3 500	100	4B
	52.6	2 000	2 000	1 750	1 700	1 350	1 100	5	12	1 750	3 500	100	4B
	65.6	2 000	2 000	1 750	1 700	1 350	1 100	4.1	12	1 750	3 500	50	4A
	85.2	1 700	1 450	1 300	1 300	1 300	1 050	2.7	12	1 750	3 500	50	4A
	106	1 150	1 150	1 150	1 150	1 150	940	1.9	12	1 750	3 500	50	4A
R4	79.5	2 000	2 000	1 750	1 700	1 350	1 100	3.5	10	1 750	3 500	50	4A
	104	2 000	2 000	1 750	1 700	1 350	1 100	2.7	10	1 750	3 500	50	4A
	136	2 000	2 000	1 750	1 700	1 350	1 100	2.2	10	1 750	3 500	50	4A
	180	2 000	2 000	1 750	1 700	1 350	1 100	1.7	10	1 750	3 500	50	4A
	222	2 000	2 000	1 750	1 700	1 350	1 100	1.4	10	1 750	3 500	50	4A
	234	2 000	2 000	1 750	1 700	1 350	1 100	1.3	10	1 750	3 500	50	4A
	292	2 000	2 000	1 750	1 700	1 350	1 100	1.1	10	1 750	3 500	50	4A
	378	2 000	2 000	1 750	1 700	1 350	1 100	0.85	10	1 750	3 500	50	4A
	472	2 000	2 000	1 750	1 700	1 350	1 100	0.67	10	1 750	3 500	50	4A
	613	1 700	1 450	1 300	1 300	1 300	1 050	0.43	10	1 750	3 500	50	4A
765	1 150	1 150	1 150	1 150	1 150	940	0.27	10	1 750	3 500	50	4A	

M_{2max}=1.2×Mn2(n2×h=10 000)

EP301L

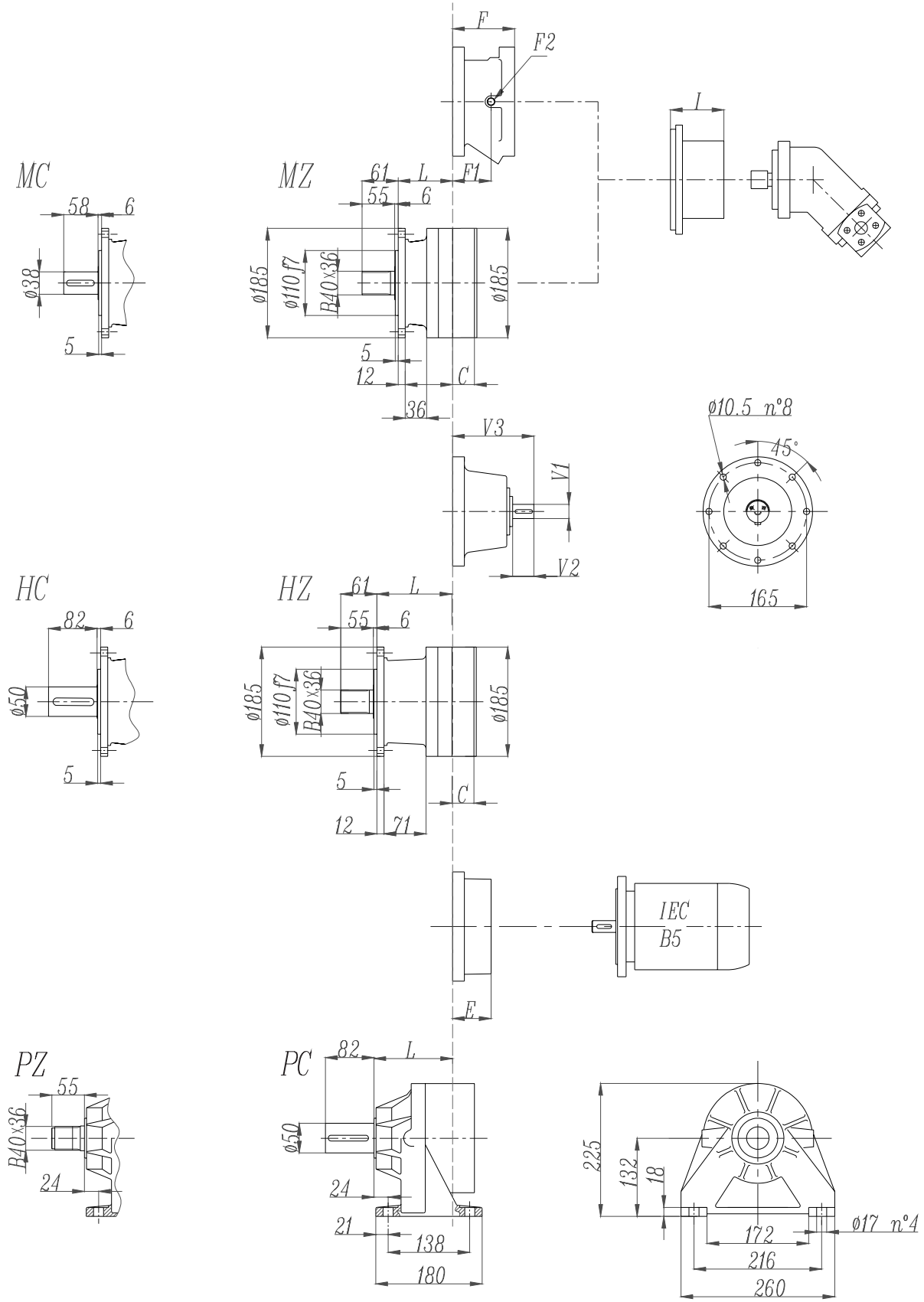

EP301L

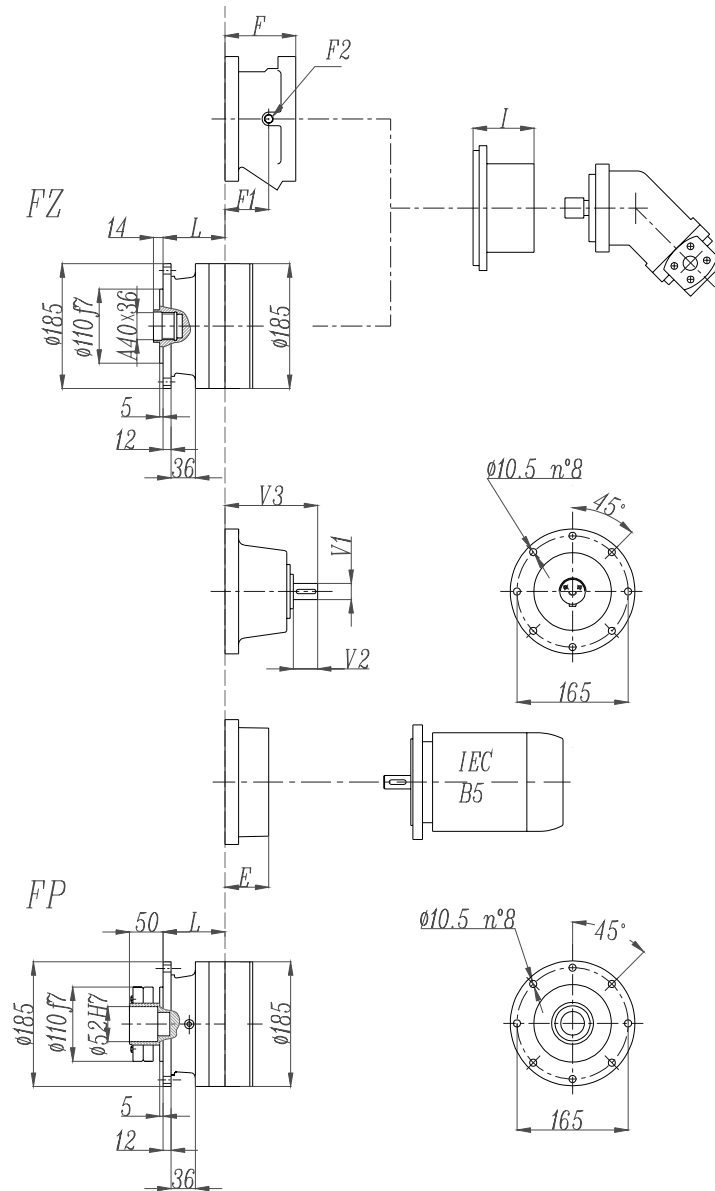

FP version
Max. transmissible
2400 N.m

	L				Ref. weight (without input) (Kg)				C	I	Brake				Ref. Weight 15 Kg
	MZ MC	FZ FP	HZ HC	PZ PC	MZ MC	FZ FP	HZ HC	PZ PC			F	F1	F2	Type	
301L1	92	92	127	133	21	19	23	26	37	According to hydraulic motor	105	65	1/4 G	4	
301L2	145	145	180	186	25	23	27	30	37		105	65	1/4 G	4	
301L3	198	198	233	239	29	27	31	34	37		105	65	1/4 G	4	
301L4	251	251	251	292	33	31	35	38	37		105	65	1/4 G	4	

	E (IEC motor input)							
		IEC71	IEC80	IEC90	IEC100	IEC112	IEC132	IEC160
301L1		65	84	84	94	94	114	144
301L2		65	84	84	94	94	114	144
301L3		65	84	84	94	94	114	144
301L4		65	84	84	94	94	114	144

EP301R

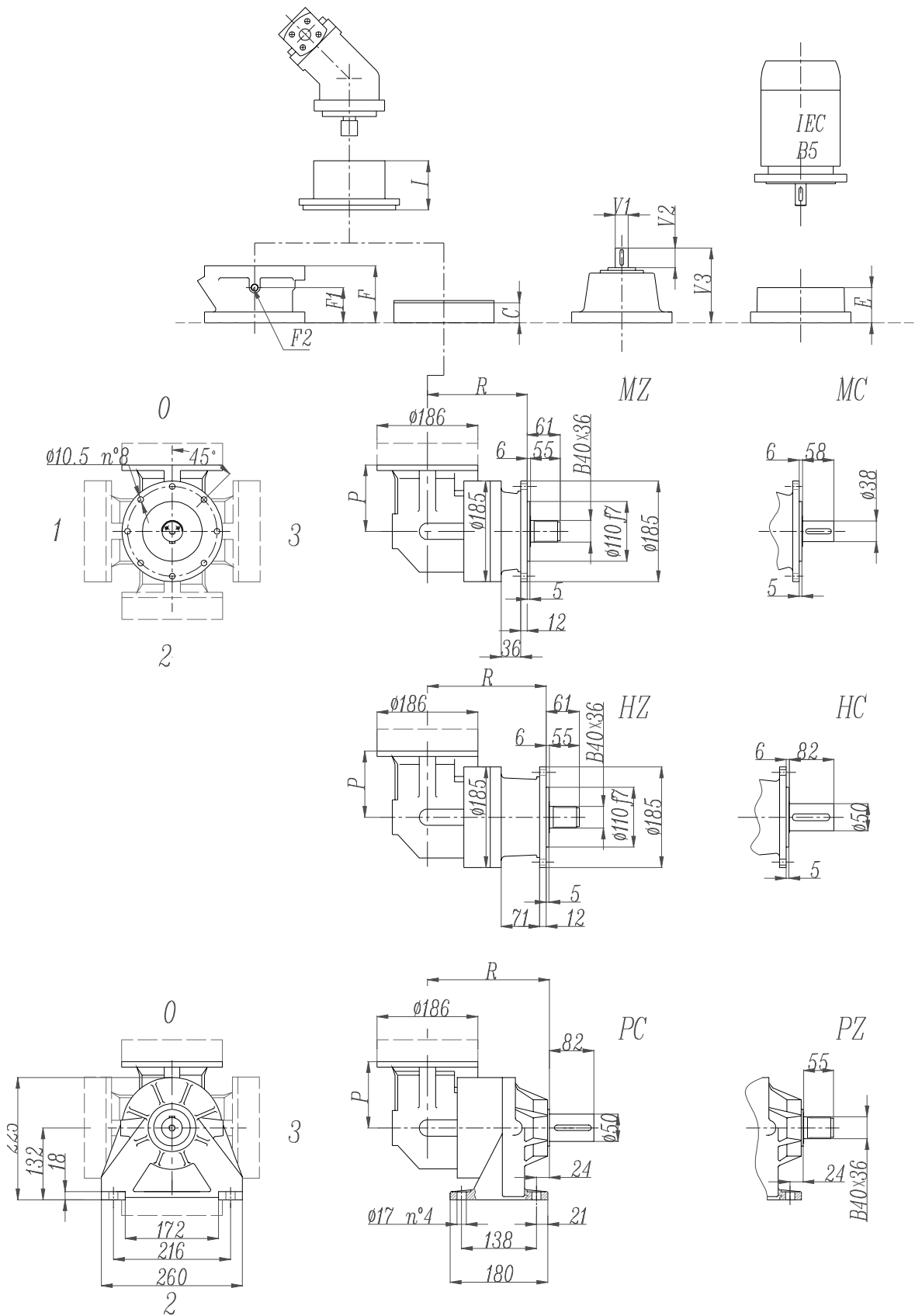

EP301R

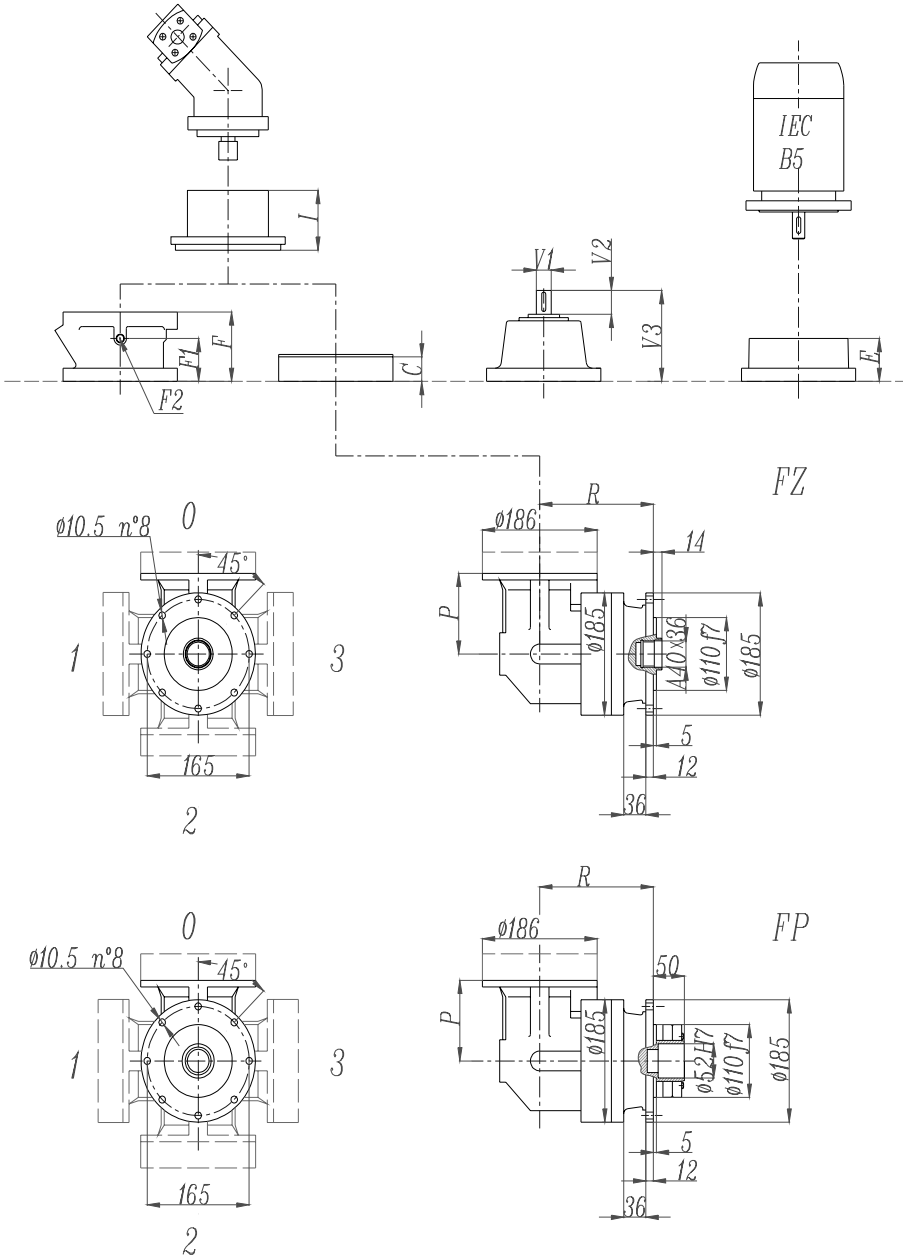

FP version
Max. transmissible
2400 N.m

	R				Ref. weight (without input) (Kg)				C	P	I	Brake				
	MZ MC	FZ FP	HZ HC	PC PZ	MZ MC	FZ FP	HZ HC	PC PZ				F	F1	F2	Type	Ref. Weight
301R2	184	184	219	225	35	33	37	40	37	122	According to hydraulic motor	105	65	1/4 G	4	15 Kg
301R3	237	237	272	278	39	37	41	44	37			105	65	1/4 G	4	
301R4	290	290	325	331	43	41	45	48	37			105	65	1/4 G	4	

	E (IEC motor input)						
		IEC71	IEC80	IEC90	IEC100	IEC112	IEC132
301R2		65	84	84	94	94	114
301R3		65	84	84	94	94	114
301R4		65	84	84	94	94	114

EP301L - EP301R

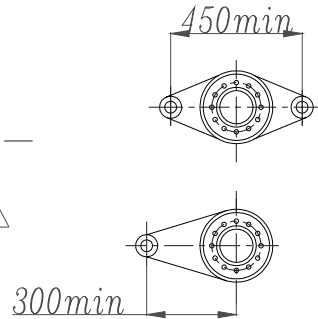
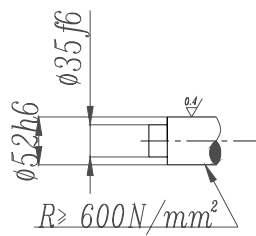
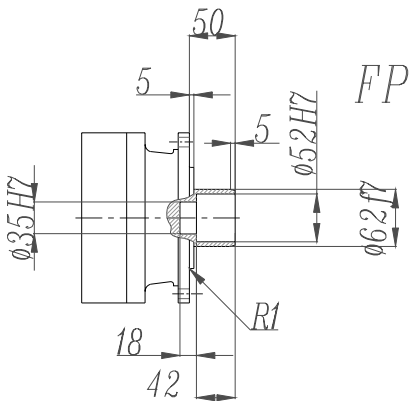
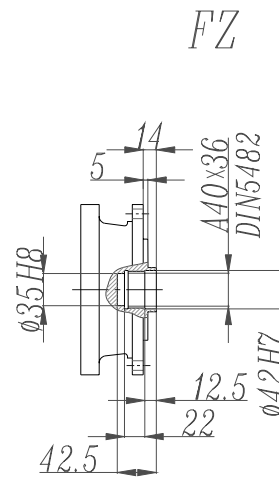
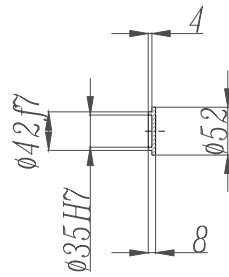
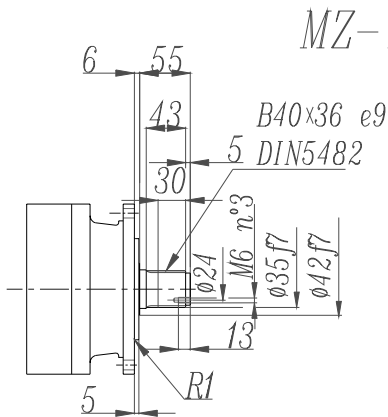
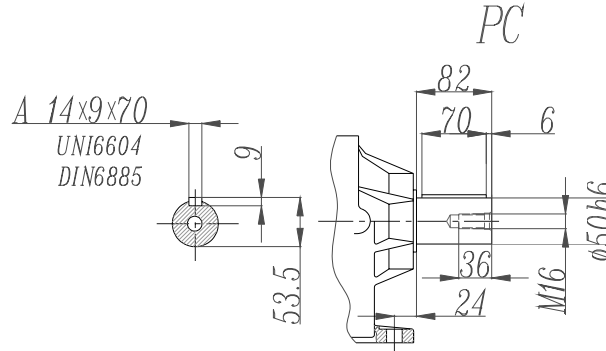
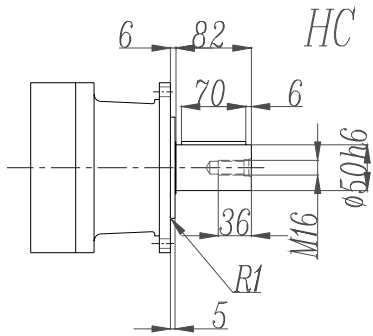
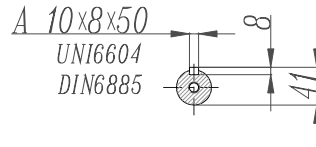
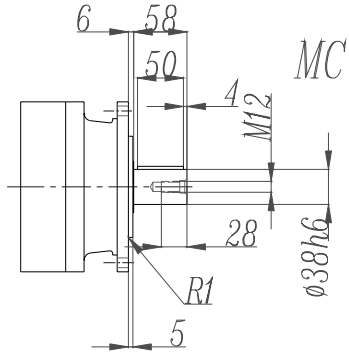

FP version
Max. transmissible
2400 N.m

EP301L - EP301R

Drive intake flange

DIF

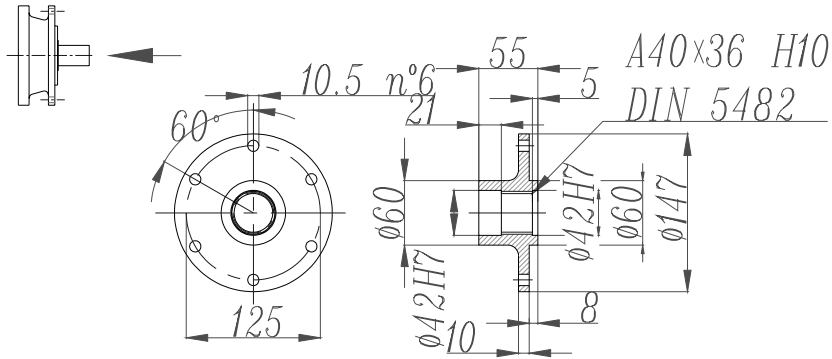

Sleeve couplings

SC

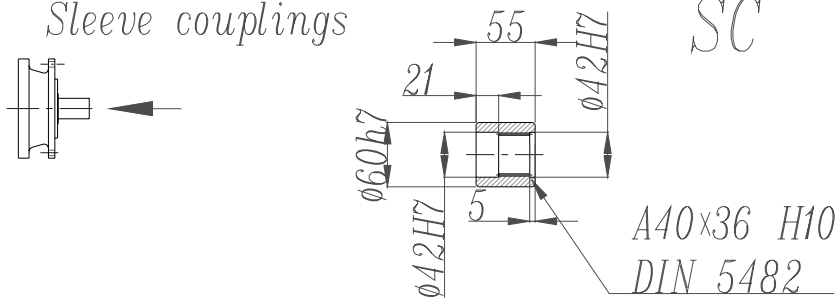

Splined bars

SB

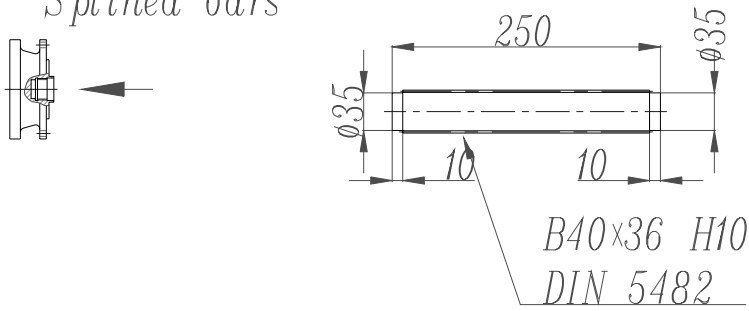

Shrink disc

SD

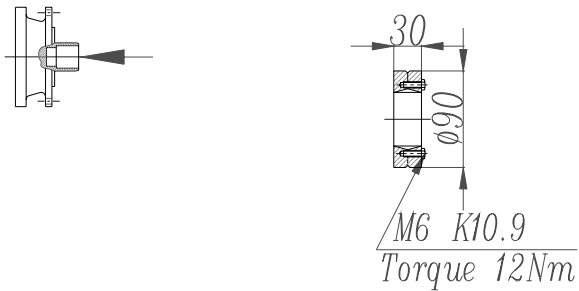

EP301L - EP301R

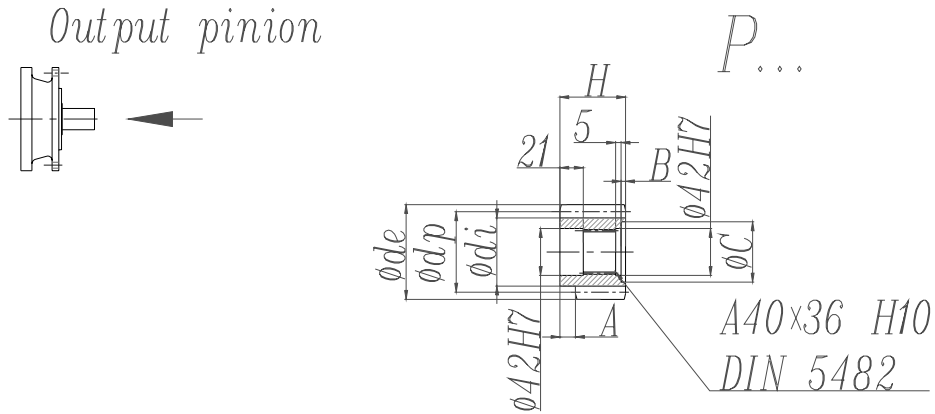

	m	z	x	dp	di	de	H	A	B	C
PBE	4.5	14	0.507	63	56	75.5	55	0	0	0
PCE	5	14	0.500	70	62.5	84.8	65	0	10	53
PDC	6	12	0.250	72	61	84.8	59	14	4	54
PDE	6	14	0.500	84	73	99.6	65	0	10	54

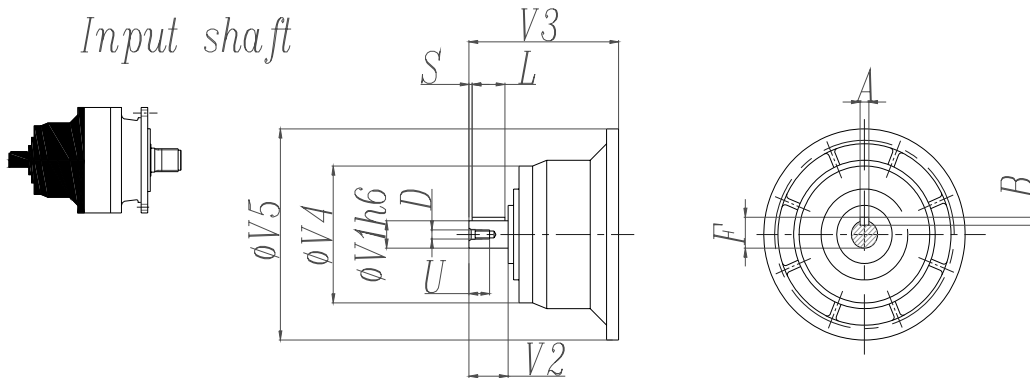

	CODE	V1	V2	V3	V4	V5	A	B	F	L	S	D	U
301L1	V01A	24	36	137.5	120	186	8	7	27	30	3	M8	19
	V01B	38	58	158	120	186	10	8	41	50	4	M12	28
301L2	V01A	24	36	137.5	120	186	8	7	27	30	3	M8	19
	V01B	38	58	158	120	186	10	8	41	50	4	M12	28
301L3	V01A	24	36	137.5	120	186	8	7	27	30	3	M8	19
	V01B	38	58	158	120	186	10	8	41	50	4	M12	28
301L4	V01A	24	36	137.5	120	186	8	7	27	30	3	M8	19
	V01B	38	58	158	120	186	10	8	41	50	4	M12	28
301R2-R3-R4	V01A	24	36	137.5	120	186	8	7	27	30	3	M8	19
	V01B	38	58	158	120	186	10	8	41	50	4	M12	28

EP301L - EP301R

Permissible radial and axial loads on output shaft with Fh2 ($n_2 \cdot h=10\ 000$)

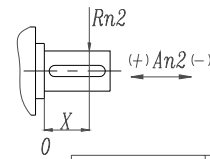
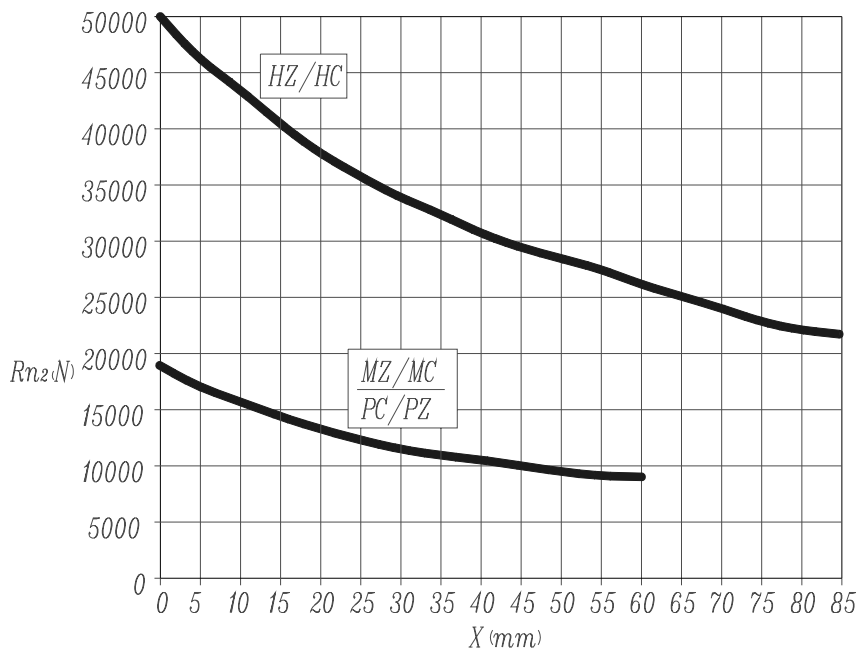

	$An_2(+)$	$An_2(-)$
MZ-MC-PC-PZ	20 000	15 000
HZ-HC	40 000	40 000

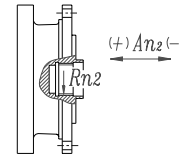

	R_{n2}	$An_2(+/-)$
FZ	8 000	8 000

Load corrective factor fh2 on shafts	fh2= $n_2 \cdot h$		10 000	25 000	50 000	100 000	500 000	1 000 000
	fh2	MZ-MC-PC-PZ-FZ	1	0.74	0.58	0.46	0.27	0.21
		HZ-HC	1	0.76	0.61	0.50	0.31	0.25

Permissible radial loads on input shaft with Fh1 ($n_1 \cdot h=250\ 000$)

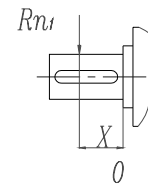
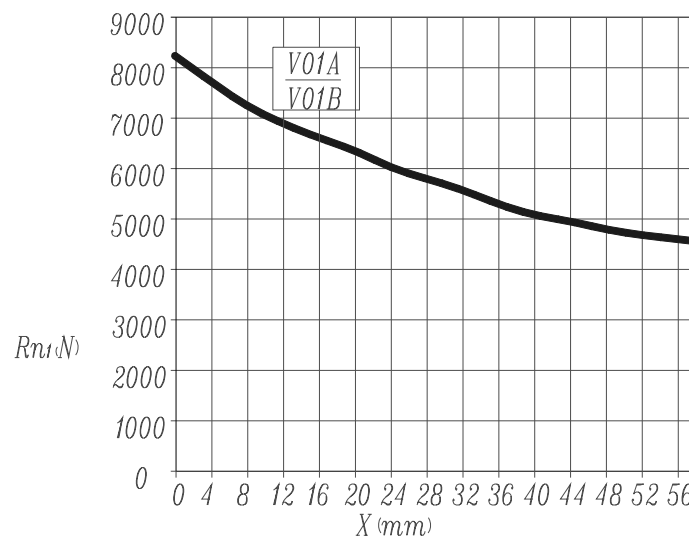

Load corrective factor fh1 on shafts	Fh1= $n_1 \cdot h$		250 000	500 000	1 000 000	2 00 000	5 000 000	10 000 000
	fh1		1	0.79	0.63	0.50	0.37	0.29

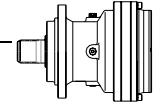

EP303L

M2'=3000N.m

	I	Mn ₂ (N.m)						P ₁ (KW)	P _t (KW) (ta=20°C) (n ₁ =1500)	n ₁ (min ⁻¹)	n _{1max} (min ⁻¹)	M _b (N.m)	Brake type
		n ₂ .h 10000	n ₂ .h 25000	n ₂ .h 50000	n ₂ .h 100000	n ₂ .h 500000	n ₂ .h 1000000						
L1	3.7	2 900	2 750	2 650	2 600	2 150	1 750	40	11	1 750	3 500	1 000	5K
	4.2	2 900	2 750	2 650	2 600	2 150	1 750	40	11	1 750	3 500	1 000	5K
	5	2 800	2 450	2 200	2 200	2 100	1 700	40	11	1 750	3 500	800	5G
	5.6	2 300	2 000	1 800	1 800	1 750	1 400	40	11	1 750	3 500	630	5E
	6.8	2 000	1 750	1 650	1 650	1 650	1 500	36	11	1 750	3 500	500	5C
L2	12.4	2 900	2 750	2 650	2 600	2 150	1 750	25	9	1 750	3 500	330	4H
	14.2	2 900	2 750	2 650	2 600	2 150	1 750	22	9	1 750	3 500	330	4H
	18.7	2 900	2 750	2 650	2 600	2 150	1 750	17	9	1 750	3 500	260	4F
	24.2	2 900	2 750	2 650	2 600	2 150	1 750	13	9	1 750	3 500	260	4F
	25.2	2 900	2 750	2 650	2 600	2 150	1 750	13	9	1 750	3 500	260	4F
	28.9	2 800	2 450	2 200	2 200	2 100	1 700	12	9	1 750	3 500	160	4D
	30	2 800	2 450	2 200	2 200	2 100	1 700	11.5	9	1 750	3 500	160	4D
	32.1	2 300	2 000	1 800	1 800	1 750	1 400	10	9	1 750	3 500	100	4B
	40.1	2 300	2 000	1 800	1 800	1 750	1 400	8	9	1 750	3 500	100	4B
	49.1	2 000	1 750	1 650	1 650	1 650	1 500	6	9	1 750	3 500	100	4B
L3	48.1	2 900	2 750	2 650	2 600	2 150	1 750	8	7.5	1 750	3 500	100	4B
	55.2	2 900	2 750	2 650	2 600	2 150	1 750	7	7.5	1 750	3 500	100	4B
	63.2	2 900	2 750	2 650	2 600	2 150	1 750	6.2	7.5	1 750	3 500	100	4B
	71.6	2 900	2 750	2 650	2 600	2 150	1 750	5.5	7.5	1 750	3 500	50	4A
	82	2 900	2 750	2 650	2 600	2 150	1 750	5	7.5	1 750	3 500	50	4A
	108	2 900	2 750	2 650	2 600	2 150	1 750	4	7.5	1 750	3 500	50	4A
	140	2 900	2 750	2 650	2 600	2 150	1 750	3.2	7.5	1 750	3 500	50	4A
	174	2 900	2 750	2 650	2 600	2 150	1 750	2.6	7.5	1 750	3 500	50	4A
	208	2 800	2 450	2 200	2 200	2 100	1 700	1.8	7.5	1 750	3 500	50	4A
	259	2 300	2 000	1 800	1 800	1 750	1 400	1.2	7.5	1 750	3 500	50	4A
354	2 000	1 750	1 650	1 650	1 650	1 500	0.8	7.5	1 750	3 500	50	4A	
L4	278	2 900	2 750	2 650	2 600	2 150	1 750	1.5	6	1 750	3 500	50	4A
	318	2 900	2 750	2 650	2 600	2 150	1 750	1.3	6	1 750	3 500	50	4A
	365	2 900	2 750	2 650	2 600	2 150	1 750	1.2	6	1 750	3 500	50	4A
	413	2 900	2 750	2 650	2 600	2 150	1 750	1	6	1 750	3 500	50	4A
	473	2 900	2 750	2 650	2 600	2 150	1 750	0.9	6	1 750	3 500	50	4A
	621	2 900	2 750	2 650	2 600	2 150	1 750	0.7	6	1 750	3 500	50	4A
	745	2 900	2 750	2 650	2 600	2 150	1 750	0.65	6	1 750	3 500	50	4A
	806	2 900	2 750	2 650	2 600	2 150	1 750	0.6	6	1 750	3 500	50	4A
	1007	2 900	2 750	2 650	2 600	2 150	1 750	0.5	6	1 750	3 500	50	4A
	1256	2 900	2 750	2 650	2 600	2 150	1 750	0.4	6	1 750	3 500	50	4A
1495	2 800	2 450	2 200	2 200	2 100	1 700	0.3	6	1 750	3 500	50	4A	
1866	2 300	2 000	1 800	1 800	1 750	1 400	0.2	6	1 750	3 500	50	4A	
2545	2 000	1 750	1 650	1 650	1 650	1 500	0.14	6	1 750	3 500	50	4A	

M_{2max}=1.2×Mn₂(n₂×h=10 000)

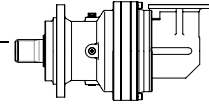

EP303R

M2'=3000N.m

	I	Mn ₂ (N.m)						P ₁	P _t (KW) (ta=20°C) (n ₁ =1500)	n ₁	n _{1max}	M _b	Brake type
		n ₂ .h 10000	n ₂ .h 25000	n ₂ .h 50000	n ₂ .h 100000	n ₂ .h 500000	n ₂ .h 1000000						
R2	9.4	2 900	2 750	2 650	2 600	2 150	1 750	35	18	1 750	3 500	400	4K
	10.8	2 900	2 750	2 650	2 600	2 150	1 750	35	18	1 750	3 500	400	4K
	12.8	2 800	2 450	2 200	2 200	2 100	1 700	27	18	1 750	3 500	330	4H
	14.3	2 300	2 000	1 800	1 800	1 750	1 400	18.9	18	1 750	3 500	260	4F
	17.5	2 000	1 750	1 650	1 650	1 650	1 500	14.3	18	1 750	3 500	160	4D
R3	25.4	2 900	2 750	2 650	2 600	2 150	1 750	14.3	14	1 750	3 500	160	4D
	29.1	2 900	2 750	2 650	2 600	2 150	1 750	15.3	14	1 750	3 500	160	4D
	38.3	2 900	2 750	2 650	2 600	2 150	1 750	12.4	14	1 750	3 500	100	4B
	49.7	2 900	2 750	2 650	2 600	2 150	1 750	8.7	14	1 750	3 500	100	4B
	51.7	2 900	2 750	2 650	2 600	2 150	1 750	9.2	14	1 750	3 500	100	4B
	51.9	2 800	2 450	2 200	2 200	2 100	1 700	6.8	14	1 750	3 500	100	4B
	59.1	2 800	2 450	2 200	2 200	2 100	1 700	4.8	14	1 750	3 500	100	4B
	61.5	2 800	2 450	2 200	2 200	2 100	1 700	5.6	14	1 750	3 500	100	4B
	65.9	2 300	2 000	1 800	1 800	1 750	1 400	4.5	14	1 750	3 500	50	4A
	82.3	2 300	2 000	1 800	1 800	1 750	1 400	3.7	14	1 750	3 500	50	4A
	101	2 000	1 750	1 650	1 650	1 650	1 500	3	14	1 750	3 500	50	4A
R4	98.6	2 900	2 750	2 650	2 600	2 150	1 750	4	12	1 750	3 500	50	4A
	113	2 900	2 750	2 650	2 600	2 000	1 650	3.6	12	1 750	3 500	50	4A
	130	2 900	2 750	2 650	2 600	2 150	1 750	3.2	12	1 750	3 500	50	4A
	147	2 900	2 750	2 650	2 600	2 000	1 650	2.9	12	1 750	3 500	50	4A
	168	2 900	2 750	2 650	2 600	2 150	1 750	2.6	12	1 750	3 500	50	4A
	221	2 900	2 750	2 650	2 600	2 000	1 650	2	12	1 750	3 500	50	4A
	287	2 900	2 750	2 650	2 600	2 150	1 750	1.6	12	1 750	3 500	50	4A
	358	2 900	2 750	2 650	2 600	2 000	1 650	1.3	12	1 750	3 500	50	4A
	426	2 800	2 450	2 200	2 200	2 100	1 700	0.9	12	1 750	3 500	50	4A
	531	2 300	2 000	1 800	1 800	1 750	1 400	0.6	12	1 750	3 500	50	4A
	725	2 000	1 750	1 650	1 650	1 650	1 500	0.43	12	1 750	3 500	50	4A

M_{2max}=1.2×Mn₂(n₂×h=10 000)

EP303L

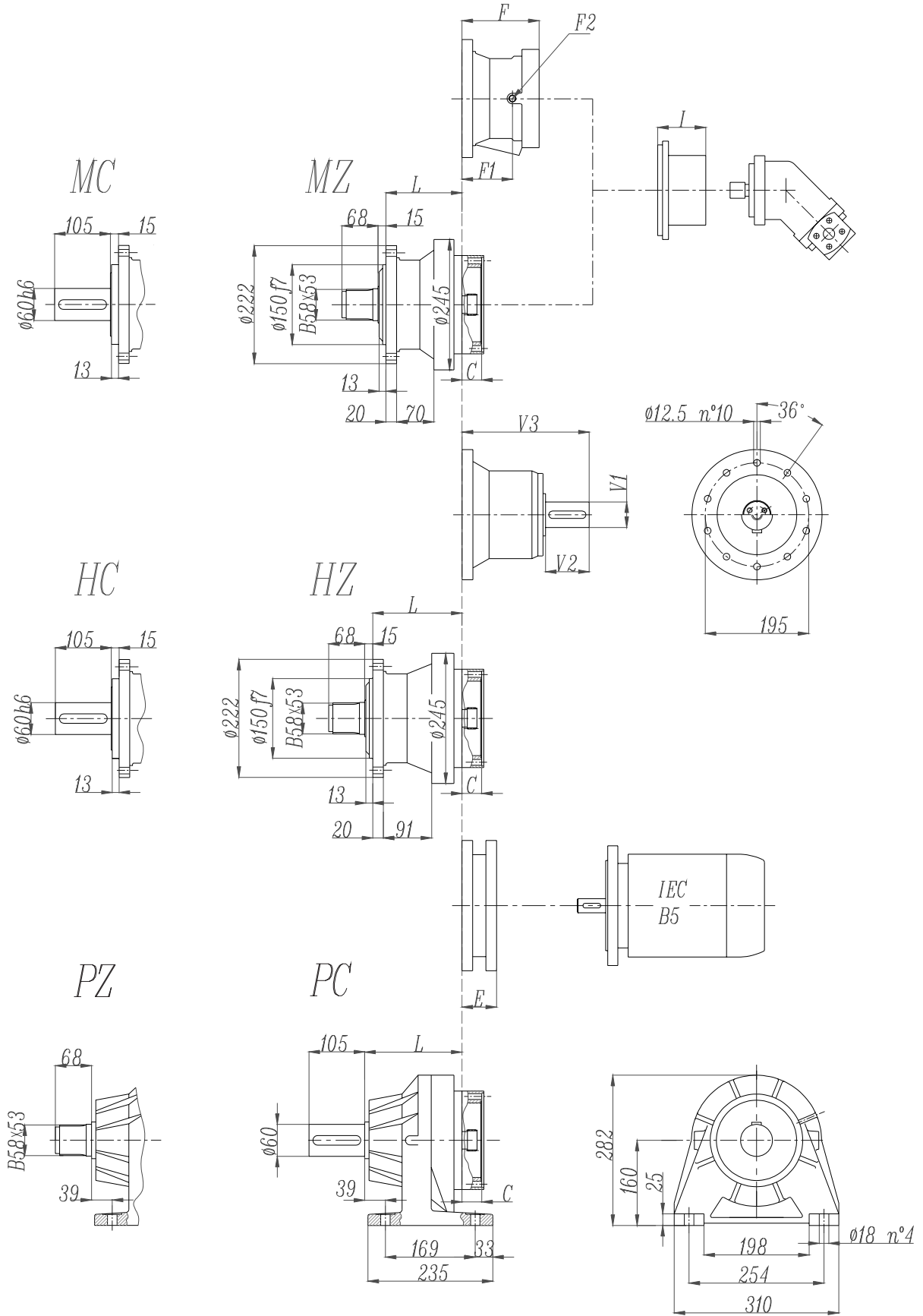

EP303L

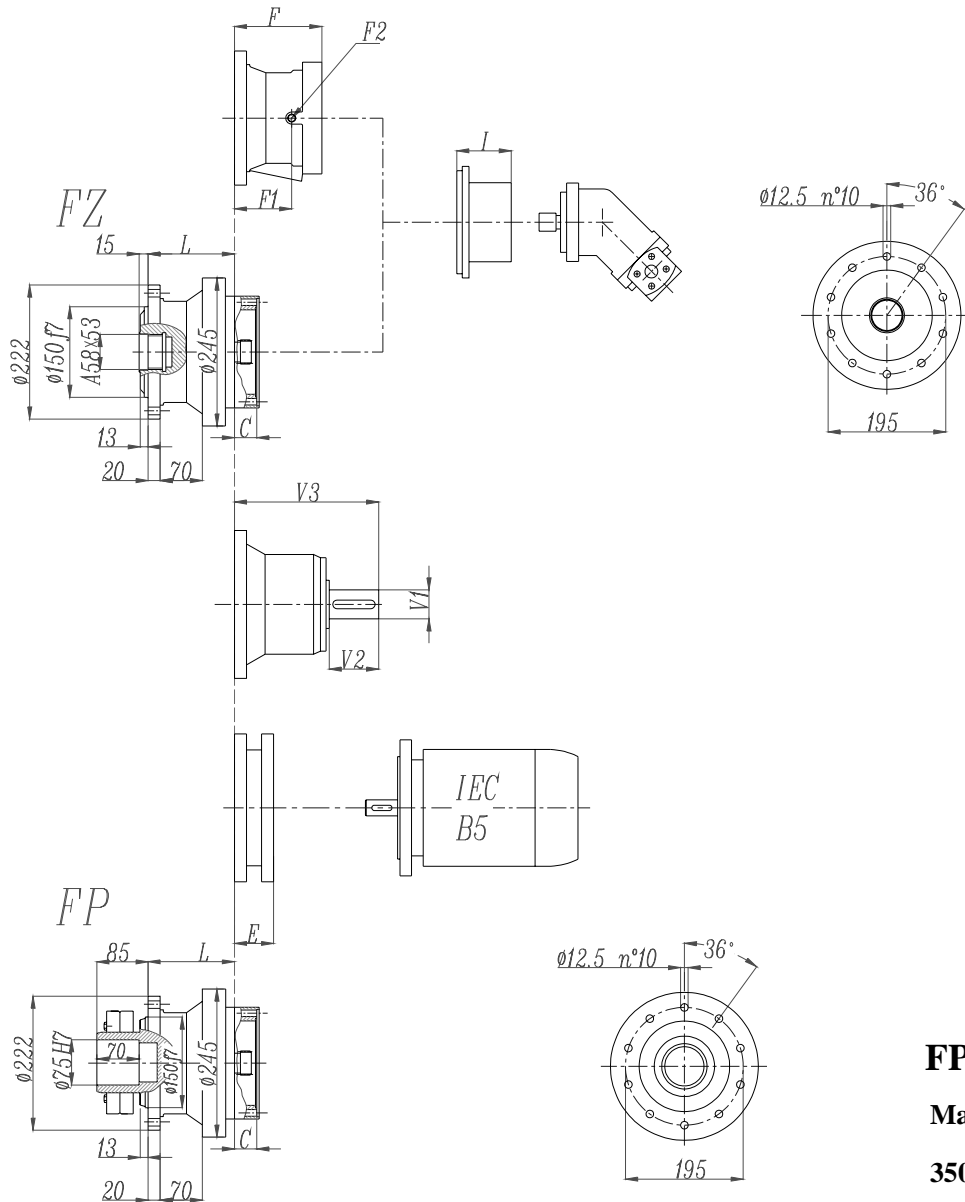

FP version
Max. transmissible
3500 N.m

	L				Ref. weight (without input) (Kg)				C	I	Brake				
	MZ MC	FZ FP	HZ HC	PC PZ	MZ MC	FZ FP	HZ HC	PC PZ			F	F1	F2	Type	Ref. Weight
303L1	129	129	154	169	31	31	35	40	37	According to hydraulic motor	145	95	1/4 G	5	15 Kg
303L2	182	182	207	222	35	35	39	44	37		105	65	1/4 G	4	
303L3	234	234	260	275	39	39	43	48	37		105	65	1/4 G	4	
303L4	288	288	313	328	43	43	47	52	37		105	65	1/4 G	4	

	E (IEC motor input)											
			IEC71	IEC80	IEC90	IEC100	IEC112	IEC132	IEC160	IEC180	IEC200	
303L1								114	144	144	174	
303L2			65	84	84	94	94	114	144			
303L3			65	84	84	94	94	114	144			
303L4			65	84	84	94	94	114	144			

EP303R

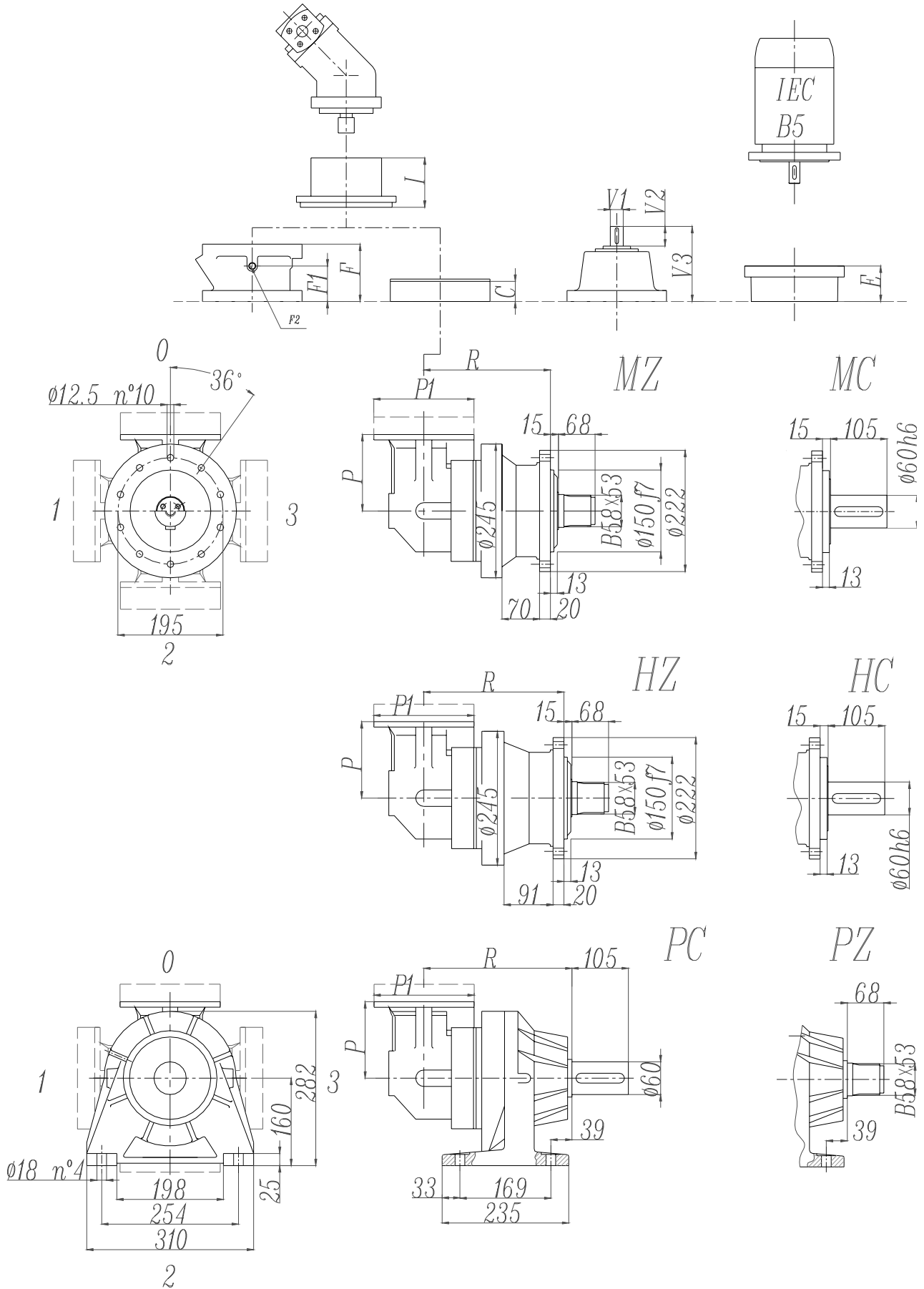

EP303R

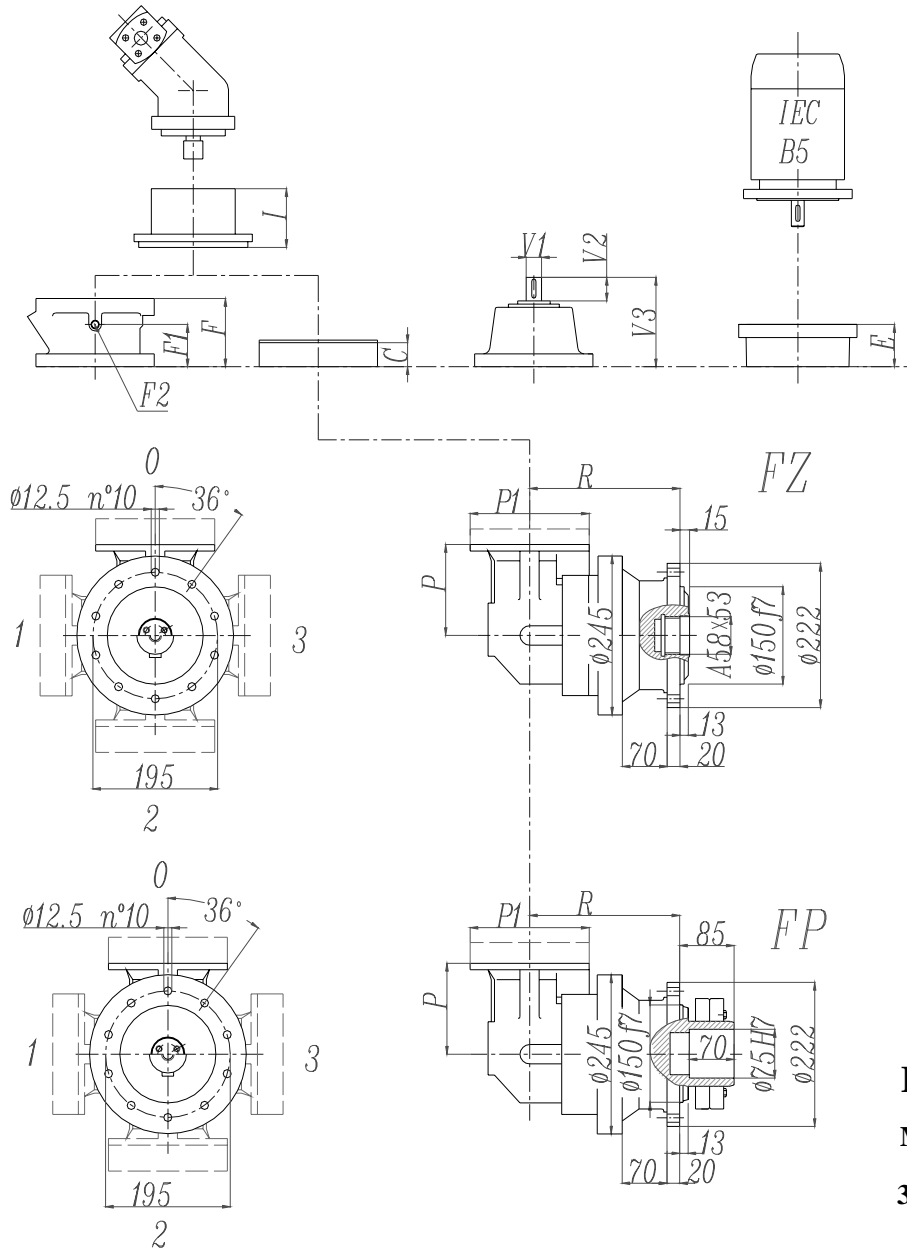

FP version
Max. transmissible
3500 N.m

	R				Ref. weight (without input) (Kg)				C	P	I	Brake				
	MZ MC	FZ FP	HZ HC	PC PZ	MZ MC	FZ FP	HZ HC	PC PZ				F	F1	F2	Type	Ref. Weight
303R2	221	221	246	261	51	51	55	60	37	140	According to hydraulic motor	105	65	1/4 G	4	15 Kg
303R3	274	274	299	314	49	49	53	58	37	122		105	65	1/4 G	4	
303R4	327	327	352	367	53	53	57	62	37	122		105	65	1/4 G	4	

	P1	E (IEC motor input)					
		IEC71	IEC80	IEC90	IEC100	IEC112	IEC132
303R2	186	65	84	84	94	94	114
303R3	186	65	84	84	94	94	114
303R4	186	65	84	84	94	94	114

EP303L - EP303R

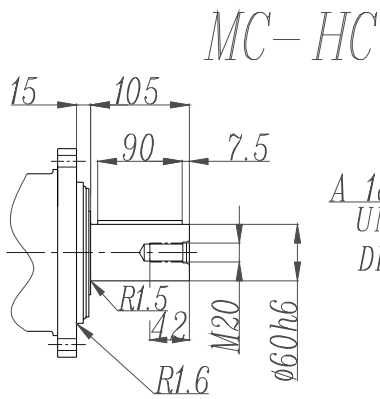

A 18x11x90
UNI6604
DIN6885

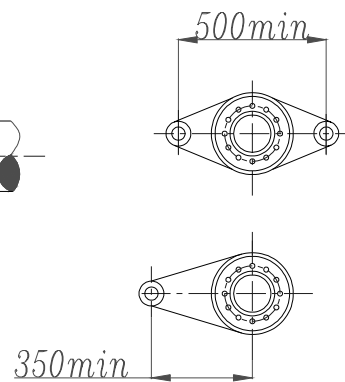
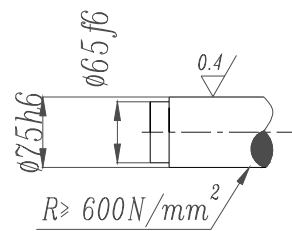
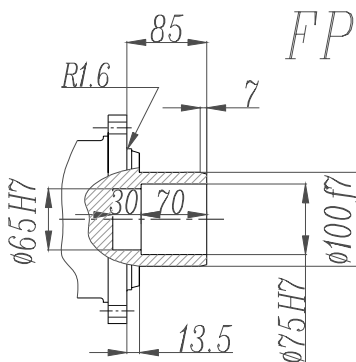
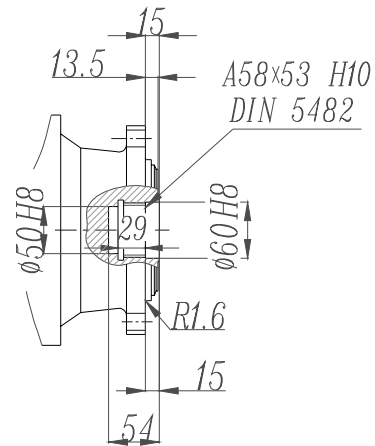
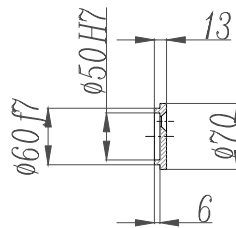
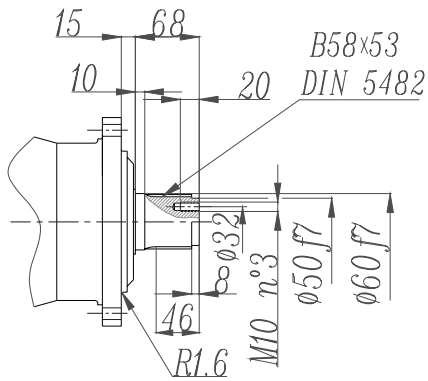
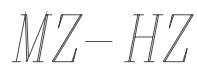
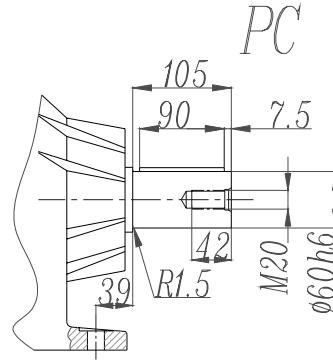

FP version

Max. transmissible

3500 N.m

EP303L - EP303R

Drive intake flange

DIF

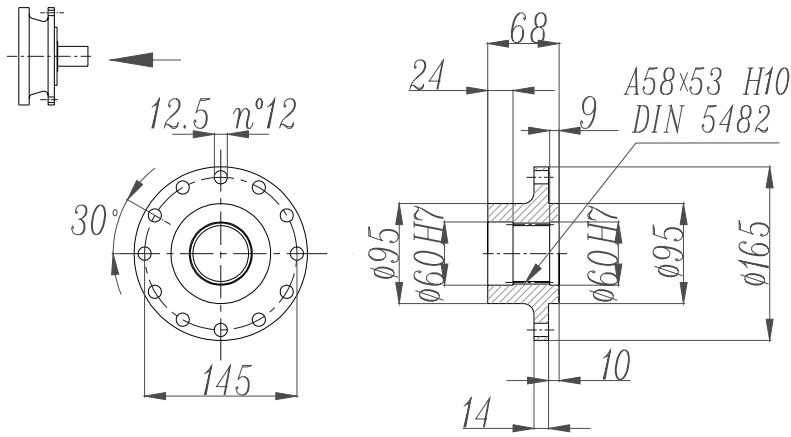

Sleeve couplings

SC

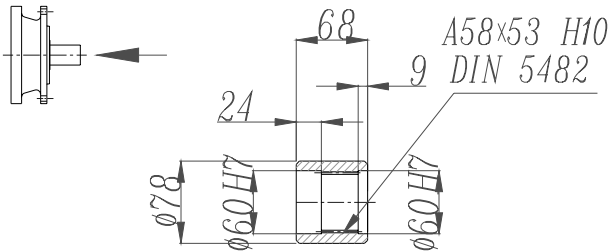

Splined bars

SB

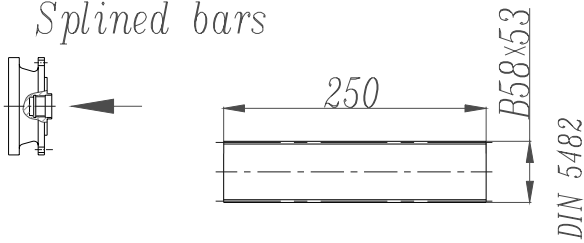

Shrink disc

SD

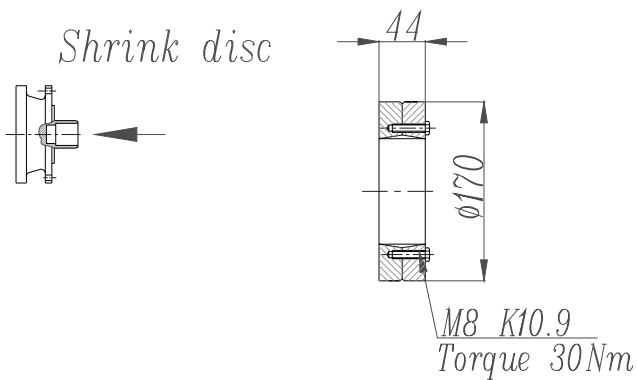

EP303L - EP303R

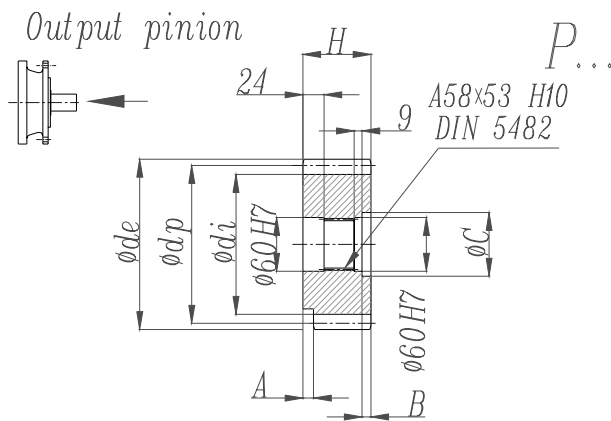

	m	z	x	dp	di	de	H	A	B	C
PCL1	5	19	0	95	82	104	77	12	9	72
PCL2	5	19	0	95	82	104	68	0	0	0
PCM	5	20	0	100	87.5	110	68	18	0	0
PCP	5	22	0	110	97.5	120	68	18	0	0
PDE	6	14	0.5000	84	75	99.6	68	0	0	0
PDI	6	18	0.5000	108	99	123.6	68	0	0	0
PDM	6	20	0.833	120	115	140	68	0	0	0
PFD	8	13	0.675	104	95	127.6	68	0	0	0
PFE1	8	14	0	112	92	126	68	0	0	0
PFE2	8	14	0	112	92	126	80	0	12	72
PFE	8	15	0	120	100	136	68	0	0	0
PFP	8	22	0	176	156	190	77	12	10	71
PHG	10	16	0.5000	160	145	188	75	0	7	72

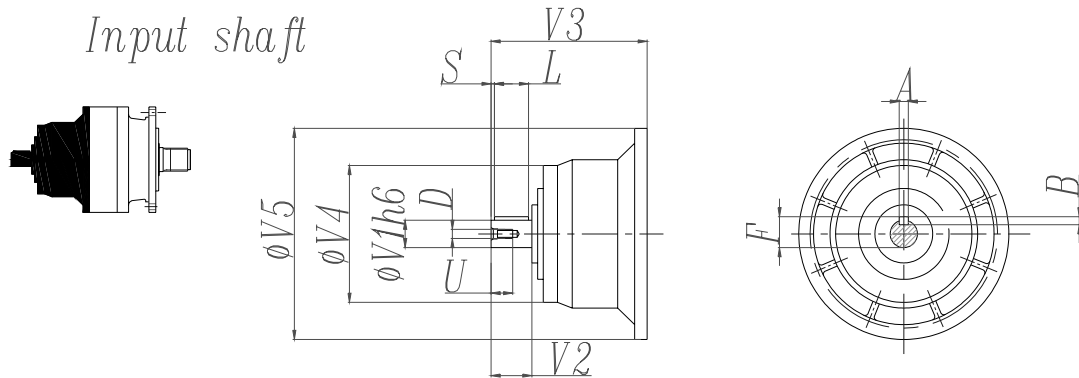

	CODE	V1	V2	V3	V4	V5	A	B	F	L	S	D	U
303L1	V05B	48	82	239	155	245	14	9	51.5	70	6	M16	36
303L2	V01A	24	36	137.5	120	186	8	7	27	30	3	M8	19
	V01B	38	58	158	120	186	10	8	41	50	4	M12	28
303L3	V01A	24	36	137.5	120	186	8	7	27	30	3	M8	19
	V01B	38	58	158	120	186	10	8	41	50	4	M12	28
303L4	V01A	24	36	137.5	120	186	8	7	27	30	3	M8	19
	V01B	38	58	158	120	186	10	8	41	50	4	M12	28
303R2-R3-R4	V01A	24	36	137.5	120	186	8	7	27	30	3	M8	19
	V01B	38	58	158	120	186	10	8	41	50	4	M12	28

EP303L - EP303R

Permissible radial and axial loads on output shaft with Fh2 ($n_2 \cdot h=10\ 000$)

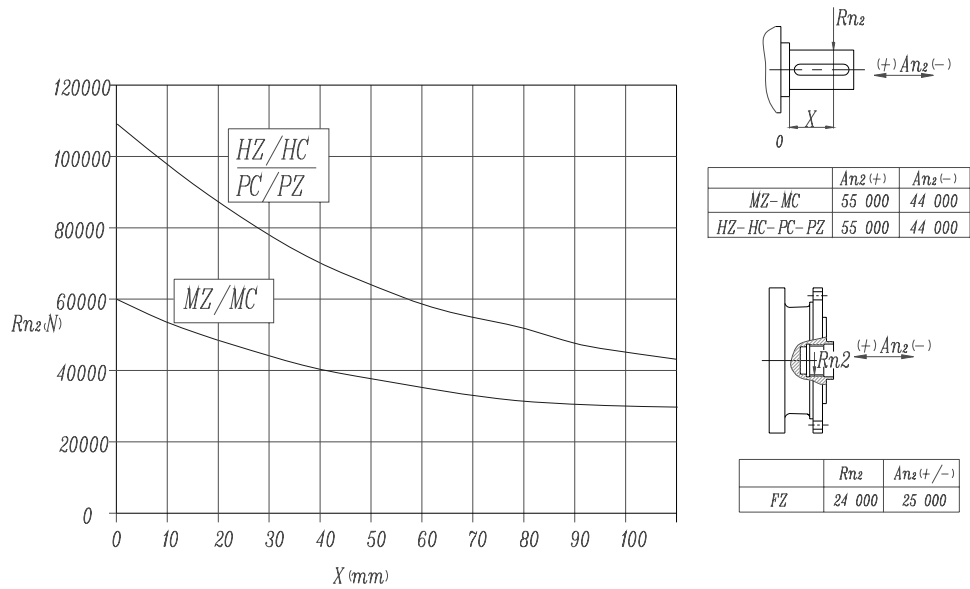

Load corrective factor fh2 on shafts	fh2= $n_2 \cdot h$		10 000	25 000	50 000	100 000	500 000	1 000 000
	fh2	MZ-MC-PC-PZ-FZ	1	0.74	0.58	0.46	0.27	0.21
		HZ-HC	1	0.76	0.61	0.50	0.31	0.25

Permissible radial loads on input shaft with Fh1 ($n_1 \cdot h=250\ 000$)

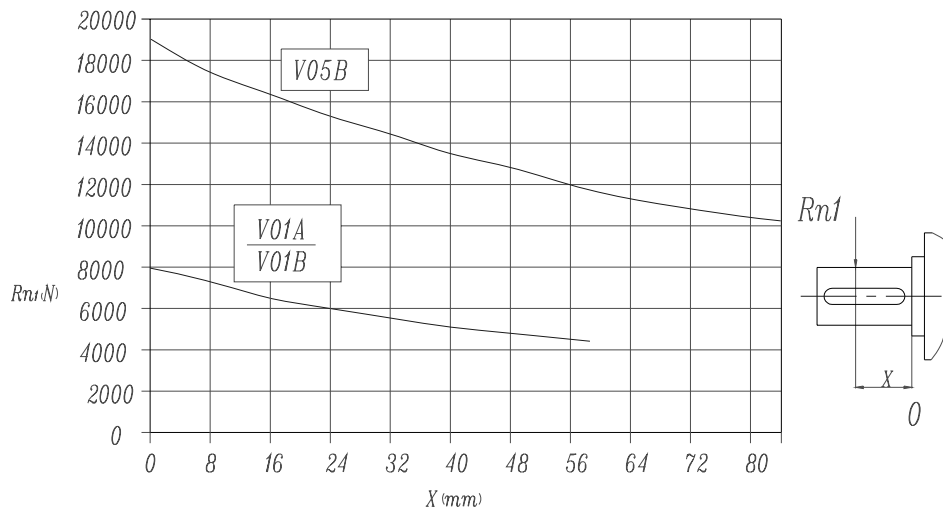

Load corrective factor fh1 on shafts	Fh1= $n_1 \cdot h$	250 000	500 000	1 000 000	2 00 000	5 000 000	10 000 000
	fh1	1	0.79	0.63	0.50	0.37	0.29

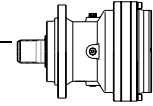

EP305L

M2'=5000N.m

	I 1:	Mn ₂ (N.m)						P ₁ (KW)	P _t (KW) (ta=20°C) (n ₁ =1500)	n ₁ (min ⁻¹)	n _{1max} (min ⁻¹)	M _b (N.m)	Brake type
		n ₂ .h 10000	n ₂ .h 25000	n ₂ .h 50000	n ₂ .h 100000	n ₂ .h 500000	n ₂ .h 1000000						
L1	3.7	5 800	5 500	5 300	5 200	3 700	3 000	60	13	1 750	3 500	1 000	5K
	4.2	5 800	5 500	5 300	5 200	3 700	3 000	60	13	1 750	3 500	1 000	5K
	5	5 600	5 100	4 400	4 400	3 600	2 950	60	13	1 750	3 500	1 000	5K
	5.6	4 600	3 950	3 600	3 600	3 500	2 900	60	13	1 750	3 500	1 000	5K
	6.8	3 800	3 300	3 100	3 100	3 000	2 400	50	13	1 750	3 500	800	5G
L2	12.4	5 800	5 500	5 300	5 200	3 700	3 000	30	9	1 750	3 500	440	4L
	14.2	5 800	5 500	5 300	5 200	3 700	3 000	30	9	1 750	3 500	440	4L
	18.7	5 800	5 500	5 300	5 200	3 700	3 000	25	9	1 750	3 500	400	4K
	24.2	5 800	5 500	5 300	5 200	3 700	3 000	22	9	1 750	3 500	260	4F
	25.2	5 800	5 500	5 300	5 200	3 700	3 000	22	9	1 750	3 500	260	4F
	28.9	5 600	5 100	4 400	4 400	3 600	2 950	20	9	1 750	3 500	260	4F
	30	5 600	5 100	4 400	4 400	3 600	2 950	19.5	9	1 750	3 500	260	4F
	32.1	4 600	3 950	3 600	3 600	3 500	2 900	18	9	1 750	3 500	260	4F
	40.1	4 600	3 950	3 600	3 600	3 500	2 900	15	9	1 750	3 500	160	4D
	49.1	3 800	3 300	3 100	3 100	3 000	2 400	10	9	1 750	3 500	100	4B
L3	48.1	5 800	5 500	5 300	5 200	3 700	3 000	12	7.5	1 750	3 500	160	4D
	55.2	5 800	5 500	5 300	5 200	3 700	3 000	10	7.5	1 750	3 500	100	4B
	63.2	5 800	5 500	5 300	5 200	3 700	3 000	9	7.5	1 750	3 500	100	4B
	71.6	5 800	5 500	5 300	5 200	3 700	3 000	9	7.5	1 750	3 500	100	4B
	82	5 800	5 500	5 300	5 200	3 700	3 000	9	7.5	1 750	3 500	100	4B
	108	5 800	5 500	5 300	5 200	3 700	3 000	7	7.5	1 750	3 500	100	4B
	140	5 800	5 500	5 300	5 200	3 700	3 000	6.2	7.5	1 750	3 500	100	4B
	174	5 800	5 500	5 300	5 200	3 700	3 000	5	7.5	1 750	3 500	50	4A
	208	5 600	5 100	4 400	4 400	3 600	2 950	3.8	7.5	1 750	3 500	50	4A
	259	4 600	3 950	3 600	3 600	3 500	2 900	2.4	7.5	1 750	3 500	50	4A
354	3 800	3 300	3 100	3 100	3 000	2 400	1.5	7.5	1 750	3 500	50	4A	
L4	318	5 800	5 500	5 300	5 200	3 700	3 000	2.9	6	1 750	3 500	50	4A
	365	5 800	5 500	5 300	5 200	3 700	3 000	2.6	6	1 750	3 500	50	4A
	413	5 800	5 500	5 300	5 200	3 700	3 000	2.3	6	1 750	3 500	50	4A
	473	5 800	5 500	5 300	5 200	3 700	3 000	2	6	1 750	3 500	50	4A
	621	5 800	5 500	5 300	5 200	3 700	3 000	1.5	6	1 750	3 500	50	4A
	745	5 800	5 500	5 300	5 200	3 700	3 000	1.3	6	1 750	3 500	50	4A
	806	5 800	5 500	5 300	5 200	3 700	3 000	1.2	6	1 750	3 500	50	4A
	1007	5 800	5 500	5 300	5 200	3 700	3 000	1	6	1 750	3 500	50	4A
	1256	5 800	5 500	5 300	5 200	3 700	3 000	0.7	6	1 750	3 500	50	4A
	1495	5 600	5 100	4 400	4 400	3 600	2 950	0.55	6	1 750	3 500	50	4A
1866	4 600	3 950	3 600	3 600	3 500	2 900	0.37	6	1 750	3 500	50	4A	
2545	3 800	3 300	3 100	3 100	3 000	2 400	0.25	6	1 750	3 500	50	4A	

M_{2max}=1.2×Mn₂(n₂×h=10 000)

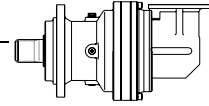

EP305R

M2'=5000N.m

	I 1:	Mn ₂ (N.m)						P ₁ (KW)	P _t (KW) (ta=20°C) (n ₁ =1500)	n ₁ (min ⁻¹)	n _{1max} (min ⁻¹)	M _b (N.m)	Brake type
		n ₂ .h 10000	n ₂ .h 25000	n ₂ .h 50000	n ₂ .h 100000	n ₂ .h 500000	n ₂ .h 1000000						
R2	9.4	4 600	4 000	3 500	3 200	2 000	1 600	35	18	1 750	3 500	440	4L
	10.8	5 000	4 600	4 100	3 500	2 100	1 700	35	18	1 750	3 500	440	4L
	12.8	5 300	4 900	4 400	4 200	2 600	2 100	27	18	1 750	3 500	440	4L
	14.3	4 600	3 950	3 600	3 600	3 500	2 900	18.9	18	1 750	3 500	330	4H
	17.5	3 800	3 300	3 100	3 100	3 000	2 400	14.3	18	1 750	3 500	260	4F
R3	25.4	5 000	4 600	4 100	3 500	2 100	1 700	13	14	1 750	3 500	260	4F
	29.1	5 300	4 900	4 400	4 200	2 600	2 100	15	14	1 750	3 500	260	4F
	38.3	5 800	5 500	5 300	5 200	3 700	3 000	14	14	1 750	3 500	260	4F
	49.7	5 800	5 500	5 300	5 200	3 700	3 000	12	14	1 750	3 500	160	4D
	51.4	5 800	5 500	5 300	5 200	3 700	3 000	12	14	1 750	3 500	160	4D
	59.1	5 600	5 100	4 400	4 400	3 600	2 950	10	14	1 750	3 500	160	4D
	61.5	5 600	5 100	4 400	4 400	3 600	2 950	10	14	1 750	3 500	100	4B
	65.9	4 600	3 950	3 600	3 600	3 500	2 900	9	14	1 750	3 500	100	4B
	82.2	4 600	3 950	3 600	3 600	3 500	2 900	7	14	1 750	3 500	100	4B
	101	3 800	3 300	3 100	3 100	3 000	2 400	5.3	14	1 750	3 500	50	4A
R4	98.6	5 800	5 500	5 300	5 200	3 700	3 000	7	12	1 750	3 500	100	4B
	113	5 800	5 500	5 300	5 200	3 700	3 000	6.1	12	1 750	3 500	100	4B
	130	5 800	5 500	5 300	5 200	3 700	3 000	5.5	12	1 750	3 500	50	4A
	147	5 800	5 500	5 300	5 200	3 700	3 000	5	12	1 750	3 500	50	4A
	168	5 800	5 500	5 300	5 200	3 700	3 000	4.5	12	1 750	3 500	50	4A
	221	5 800	5 500	5 300	5 200	3 700	3 000	4	12	1 750	3 500	50	4A
	287	5 800	5 500	5 300	5 200	3 700	3 000	3.3	12	1 750	3 500	50	4A
	358	5 800	5 500	5 300	5 200	3 700	3 000	2.6	12	1 750	3 500	50	4A
	426	5 600	5 100	4 400	4 400	3 600	2 950	1.9	12	1 750	3 500	50	4A
	531	4 600	3 950	3 600	3 600	3 500	2 900	1.2	12	1 750	3 500	50	4A
725	3 800	3 300	3 100	3 100	3 000	2 400	0.75	12	1 750	3 500	50	4A	

M_{2max}=1.2×Mn₂(n₂×h=10 000)

EP305L

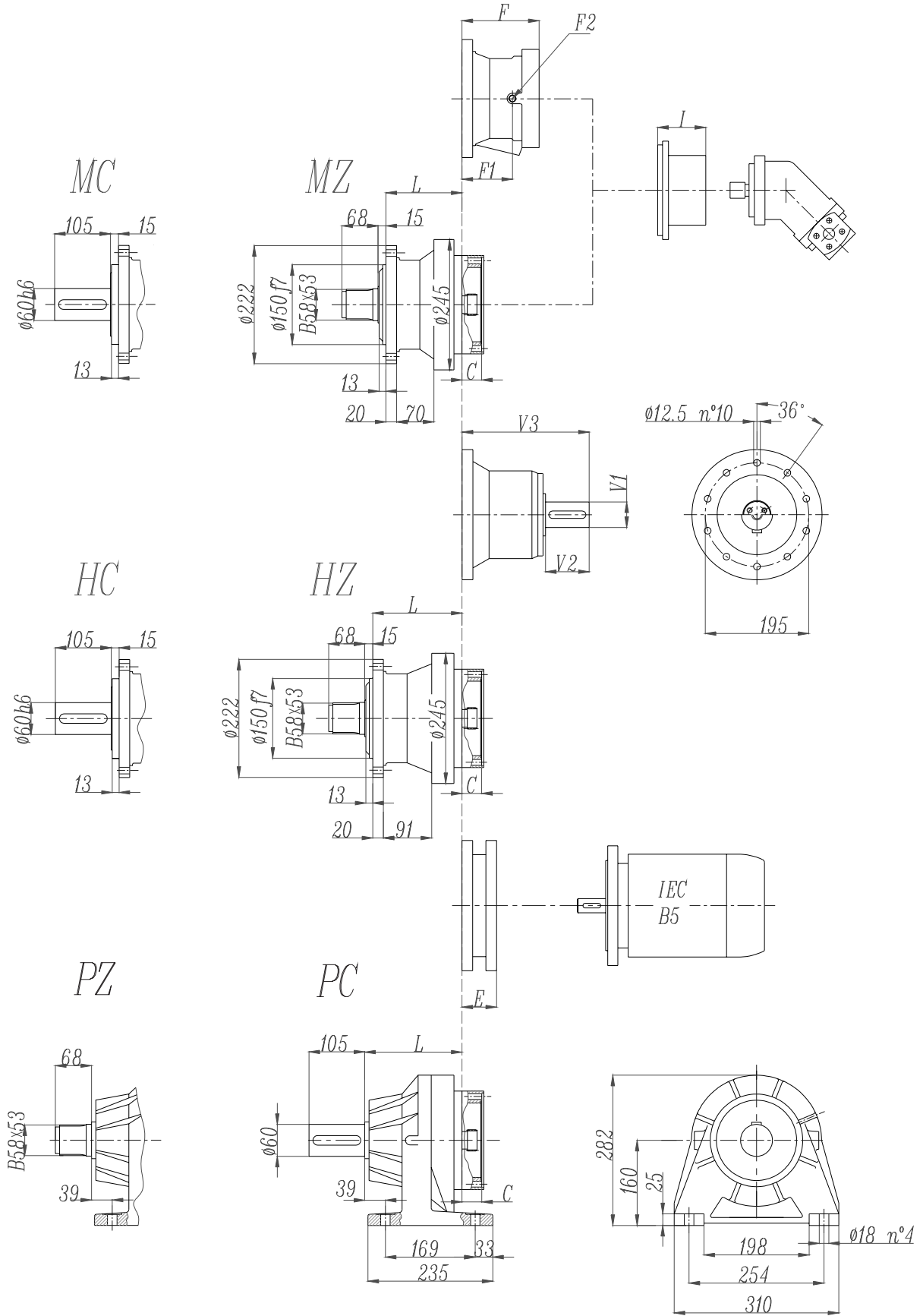

EP305L

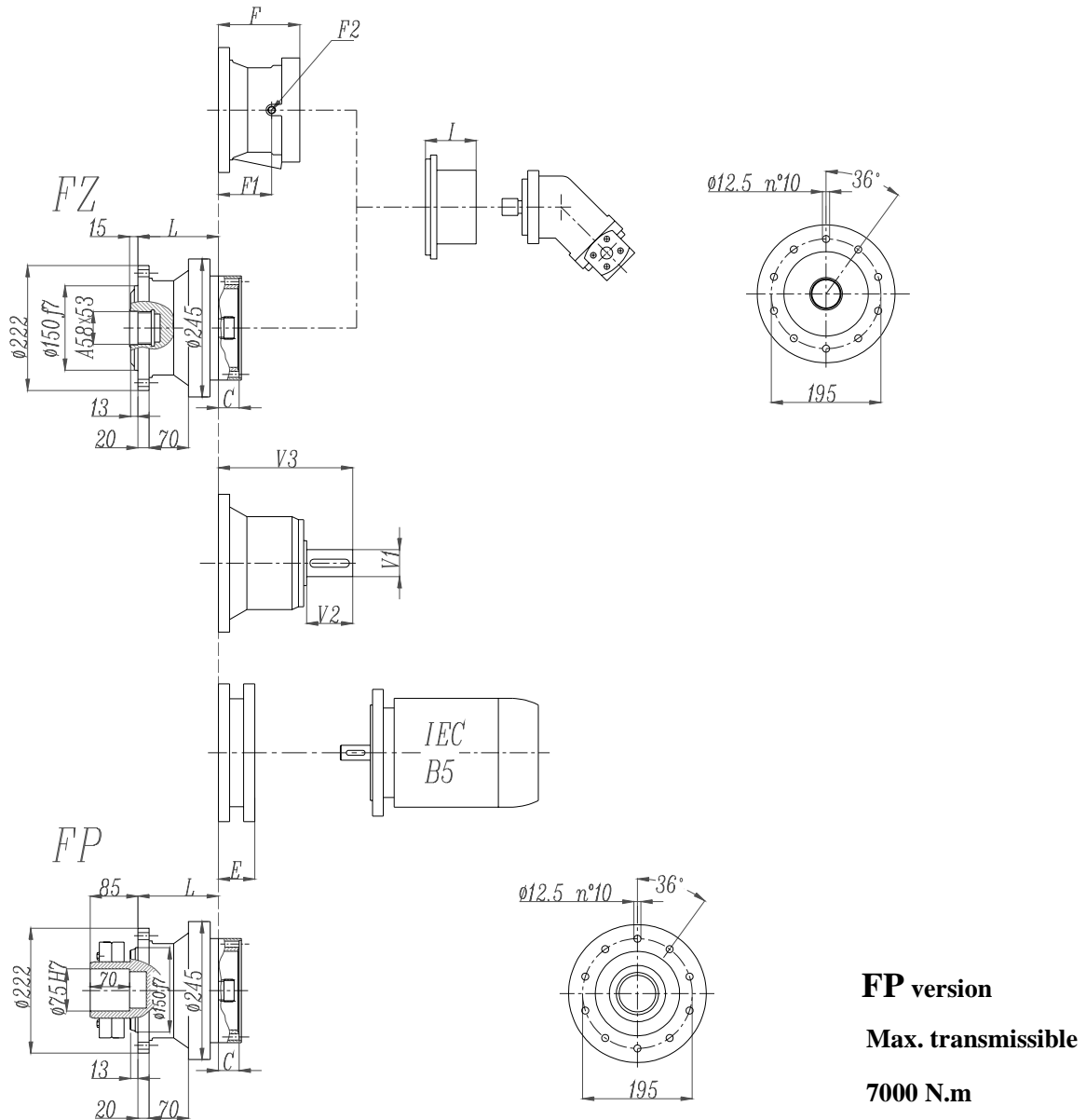

FP version
Max. transmissible
7000 N.m

	L				Ref. weight (without input) (Kg)				C	I	Brake				
	MZ MC	FZ FP	HZ HC	PC PZ	MZ MC	FZ FP	HZ HC	PC PZ			F	F1	F2	Type	Ref. Weight
305L1	147	147	172	187	36	36	40	45	37	According to hydraulic motor	145	95	1/4 G	5	22 Kg
305L2	212	212	237	252	43	43	47	52	37		105	65	1/4 G	4	
305L3	265	265	292	305	47	47	51	56	37		105	65	1/4 G	4	
305L4	318	318	343	358	51	51	55	60	37		105	65	1/4 G	4	

	E (IEC motor input)											
			IEC71	IEC80	IEC90	IEC100	IEC112	IEC132	IEC160	IEC180	IEC200	
305L1								114	144	144	174	
305L2			65	84	84	94	94	114	144			
305L3			65	84	84	94	94	114	144			
305L4			65	84	84	94	94	114	144			

EP305R

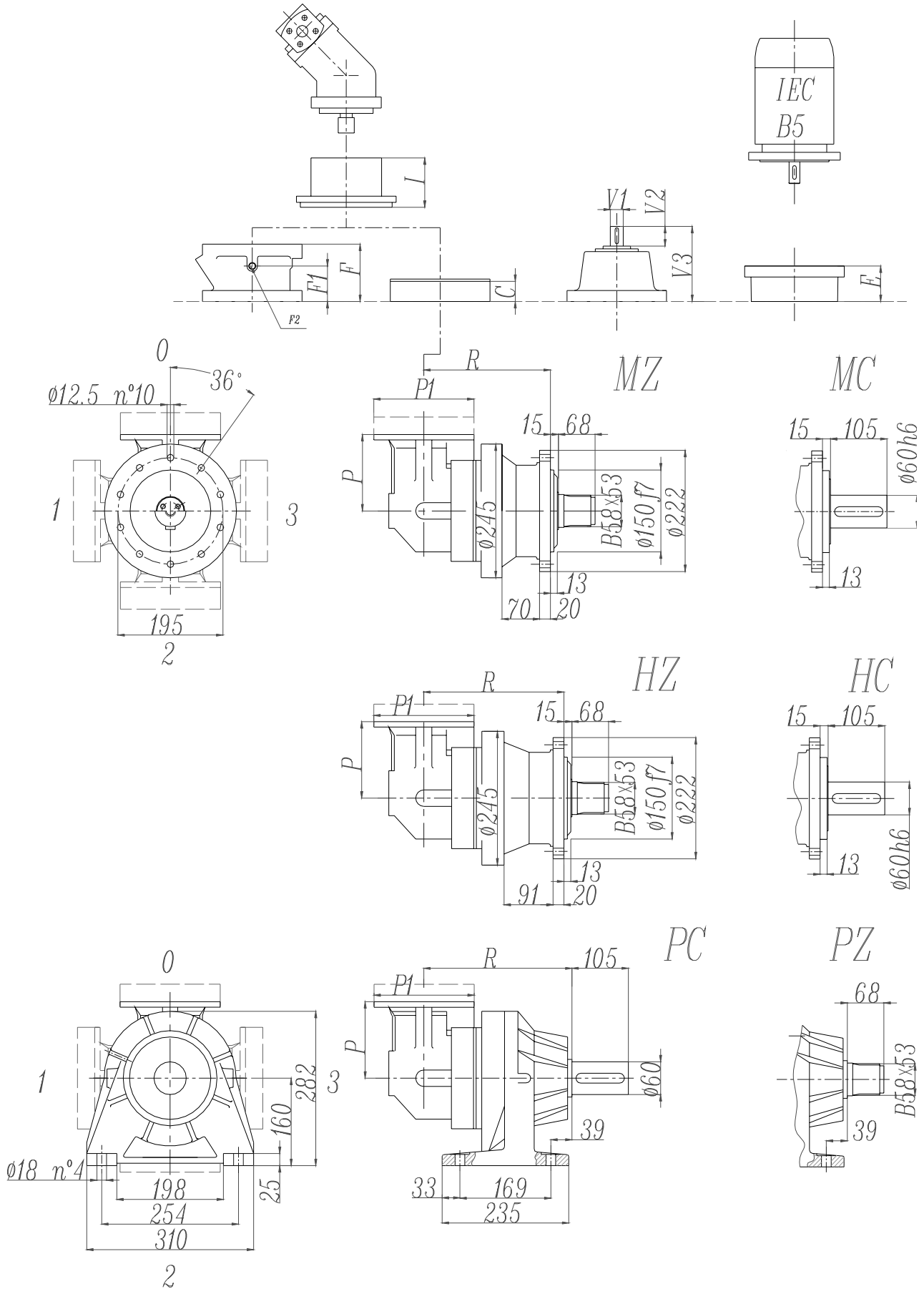

EP305R

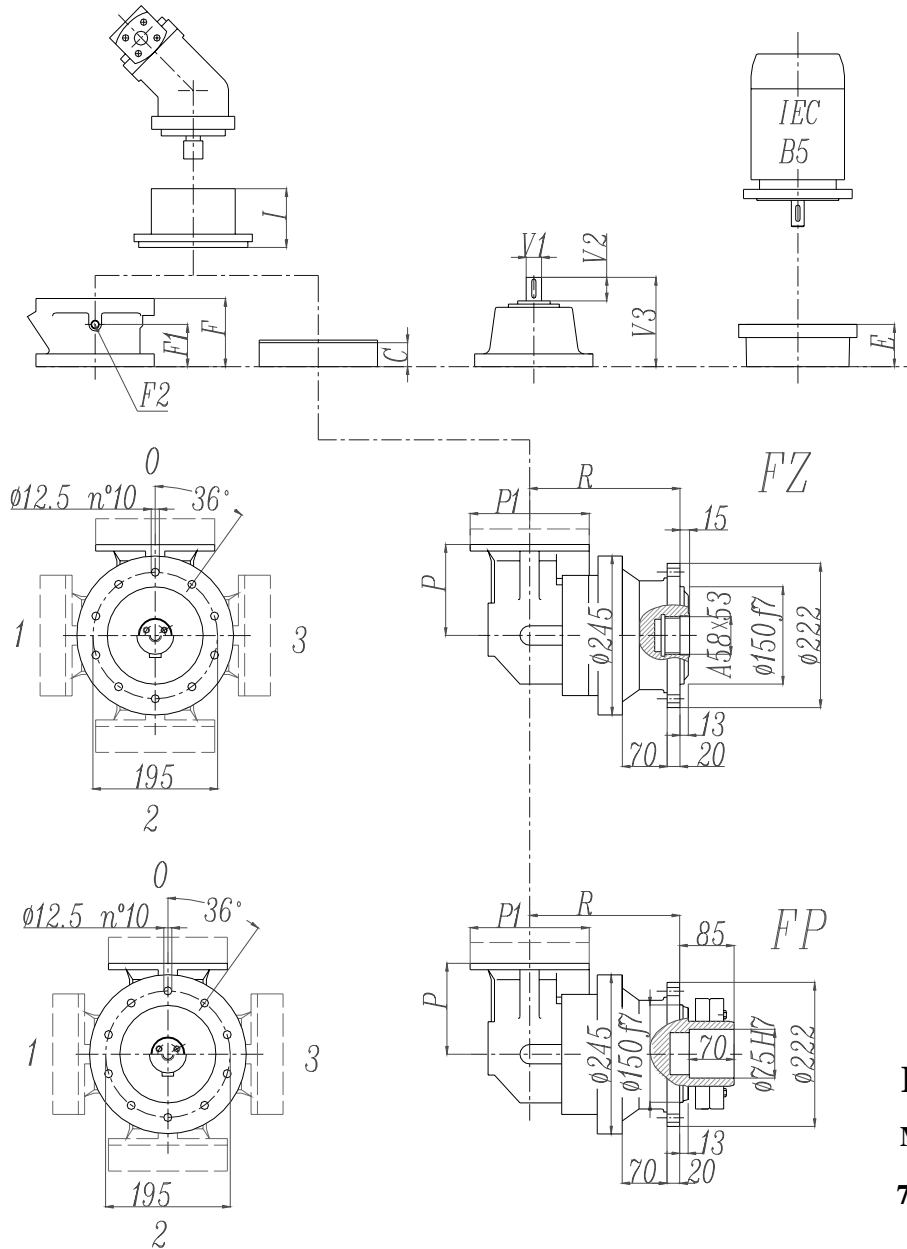

FP version
Max. transmissible
7000 N.m

	R				Ref. weight (without input) (Kg)				C	P	I	Brake				
	MZ MC	FZ FP	HZ HC	PC PZ	MZ MC	FZ FP	HZ HC	PC PZ				F	F1	F2	Type	Ref. Weight
305R2	239	239	264	279	51	51	55	60	37	140	According to hydraulic motor	105	65	1/4 G	4	15 Kg
305R3	304	304	329	344	49	49	53	58	37	122		105	65	1/4 G	4	
305R4	357	357	382	397	53	53	57	62	37	122		105	65	1/4 G	4	

	P1	E (IEC motor input)					
		IEC71	IEC80	IEC90	IEC100	IEC112	IEC132
305R2	186	65	84	84	94	94	114
305R3	186	65	84	84	94	94	114
305R4	186	65	84	84	94	94	114

EP305L - EP305R

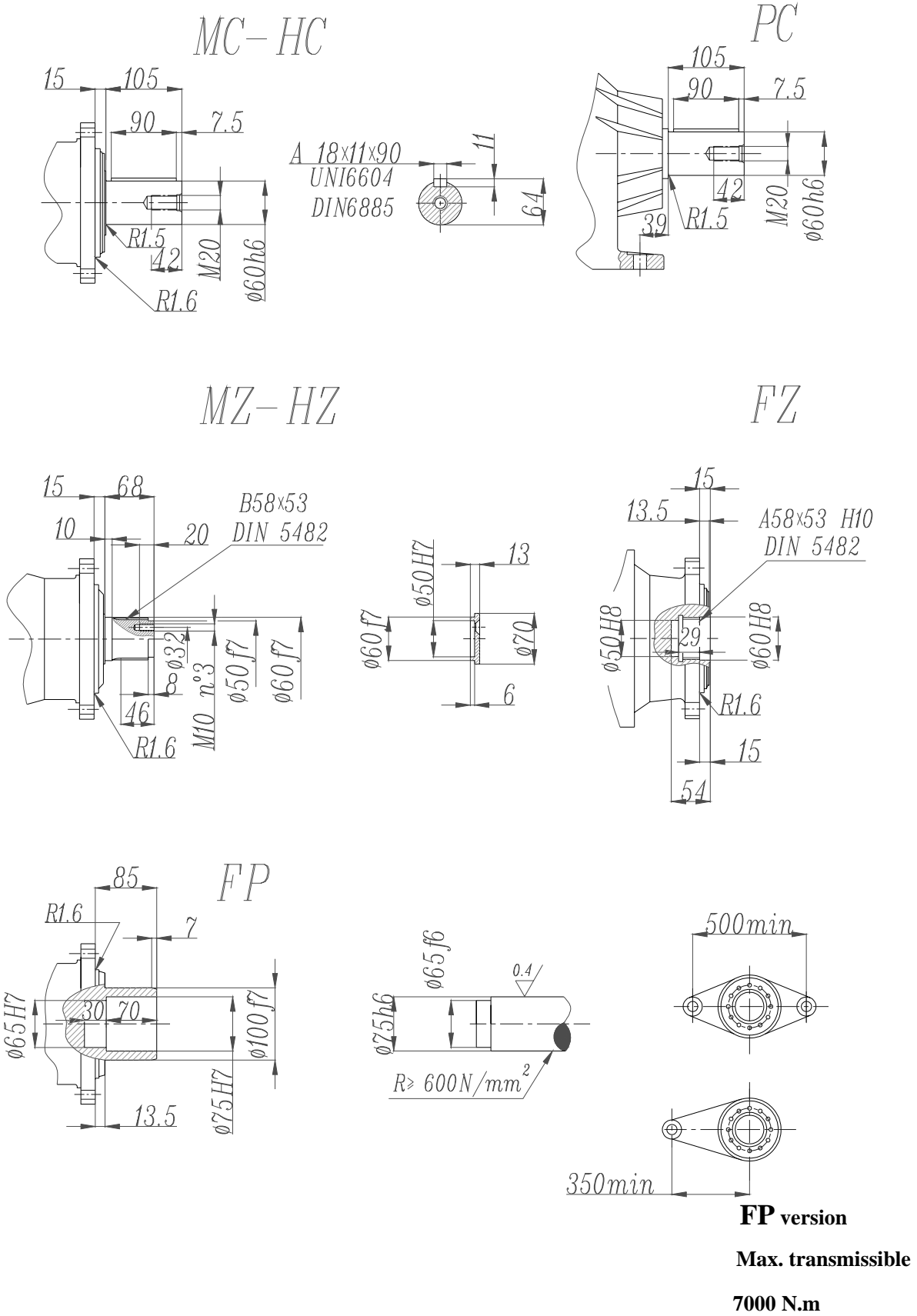

EP305L - EP305R

Drive intake flange

DIF

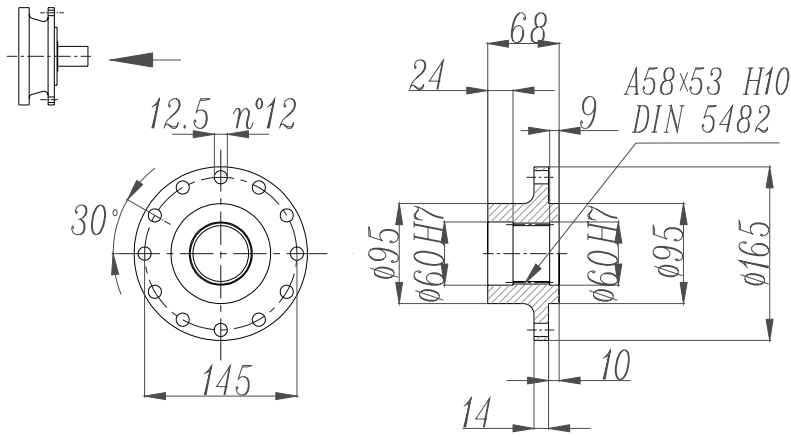

Sleeve couplings

SC

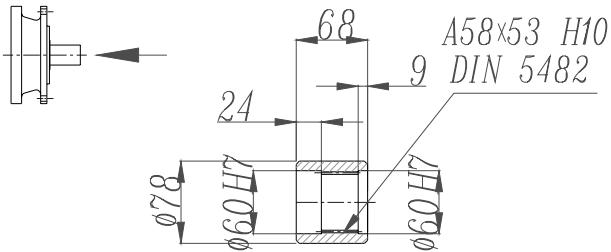

Splined bars

SB

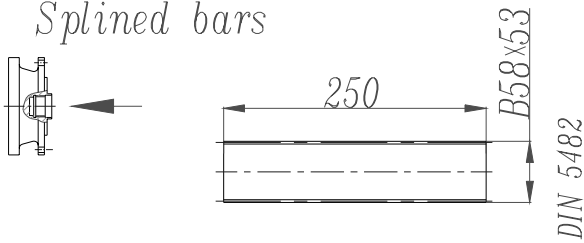

Shrink disc

SD

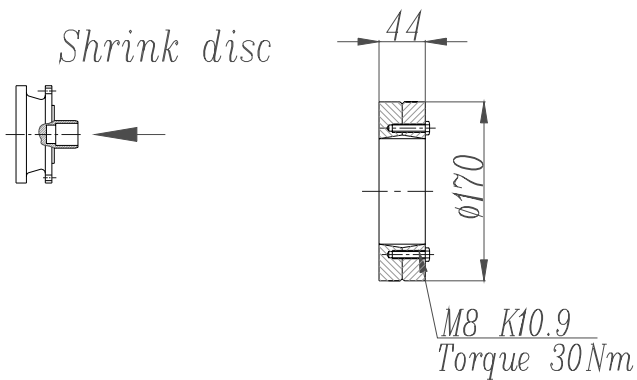

EP305L - EP305R

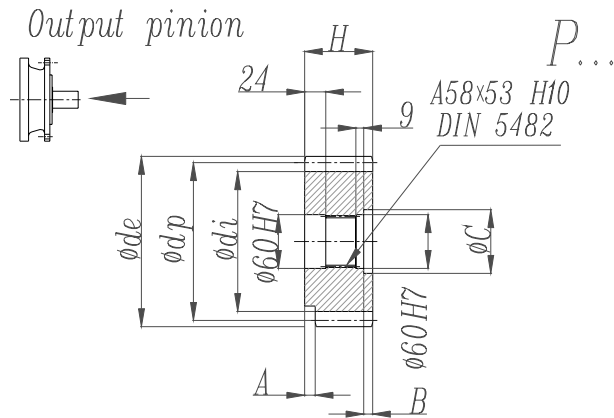

	m	z	x	dp	di	de	H	A	B	C
PCL1	5	19	0	95	82	104	77	12	9	72
PCL2	5	19	0	95	82	104	68	0	0	0
PCM	5	20	0	100	87.5	110	68	18	0	0
PCP	5	22	0	110	97.5	120	68	18	0	0
PDE	6	14	0.5000	84	75	99.6	68	0	0	0
PDI	6	18	0.5000	108	99	123.6	68	0	0	0
PDM	6	20	0.833	120	115	140	68	0	0	0
PFD	8	13	0.675	104	95	127.6	68	0	0	0
PFE1	8	14	0	112	92	126	68	0	0	0
PFE2	8	14	0	112	92	126	80	0	12	72
PFE	8	15	0	120	100	136	68	0	0	0
PFP	8	22	0	176	156	190	77	12	10	71
PHG	10	16	0.5000	160	145	188	75	0	7	72

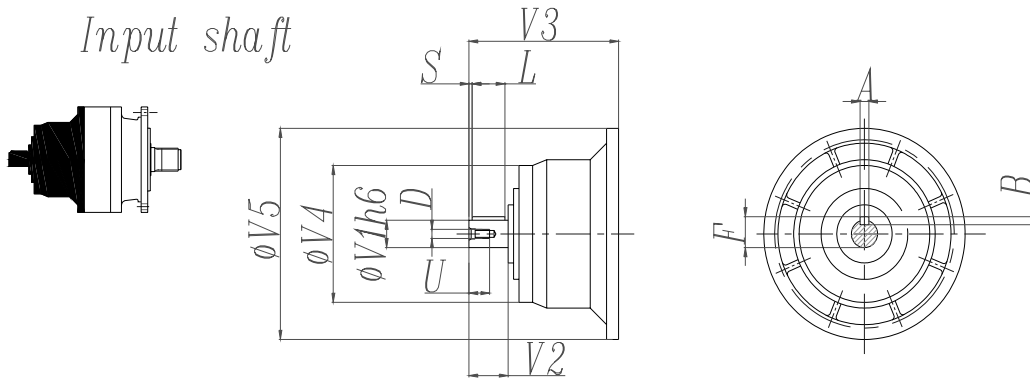

	CODE	V1	V2	V3	V4	V5	A	B	F	L	S	D	U
305L1	V05B	48	82	239	155	245	14	9	51.5	70	6	M16	36
305L2	V01A	24	36	137.5	120	186	8	7	27	30	3	M8	19
	V01B	38	58	158	120	186	10	8	41	50	4	M12	28
305L3	V01A	24	36	137.5	120	186	8	7	27	30	3	M8	19
	V01B	38	58	158	120	186	10	8	41	50	4	M12	28
305L4	V01A	24	36	137.5	120	186	8	7	27	30	3	M8	19
	V01B	38	58	158	120	186	10	8	41	50	4	M12	28
305R2-R3-R4	V01A	24	36	137.5	120	186	8	7	27	30	3	M8	19
	V01B	38	58	158	120	186	10	8	41	50	4	M12	28

EP305L - EP305R

Permissible radial and axial loads on output shaft with Fh2 ($n_2 \cdot h=10\ 000$)

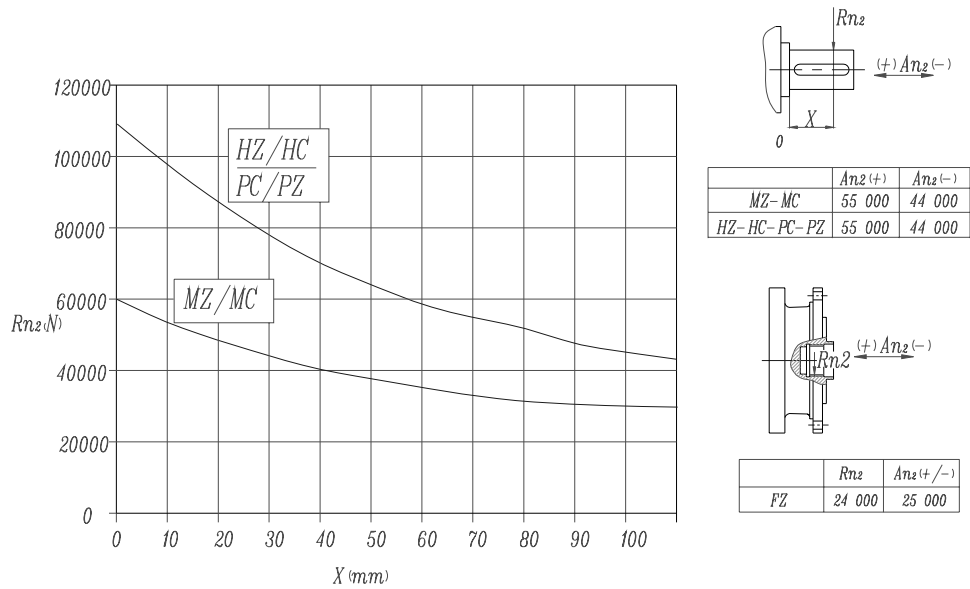

Load corrective factor fh2 on shafts	fh2= $n_2 \cdot h$		10 000	25 000	50 000	100 000	500 000	1 000 000
	fh2	MZ-MC-PC-PZ-FZ	1	0.74	0.58	0.46	0.27	0.21
		HZ-HC	1	0.76	0.61	0.50	0.31	0.25

Permissible radial loads on input shaft with Fh1 ($n_1 \cdot h=250\ 000$)

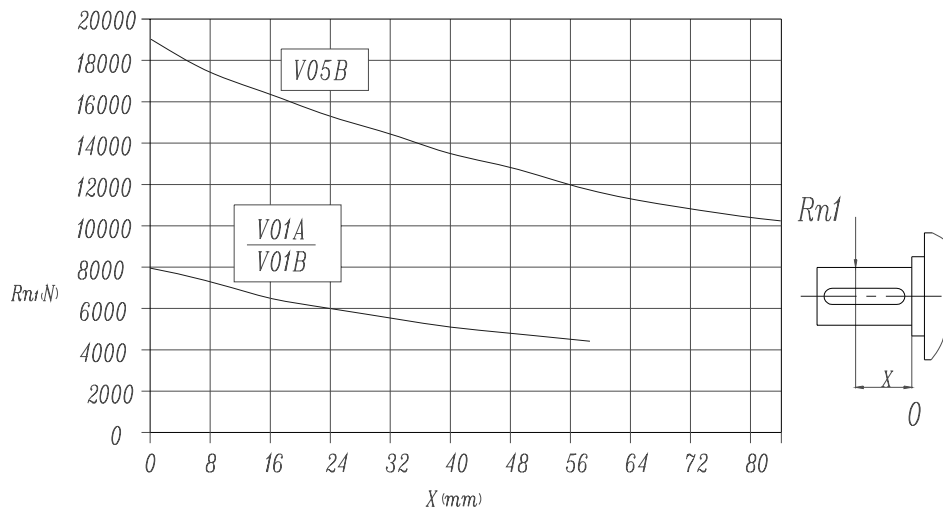

Load corrective factor fh1 on shafts	Fh1= $n_1 \cdot h$	250 000	500 000	1 000 000	2 00 000	5 000 000	10 000 000
	fh1	1	0.79	0.63	0.50	0.37	0.29

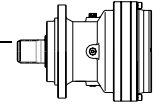

EP306L

M2'=8500N.m

	I 1:	Mn ₂ (N.m)						P ₁ (KW)	P _t (KW) (ta=20°C) (n ₁ =1500)	n ₁ (min ⁻¹)	n _{1max} (min ⁻¹)	M _b (N.m)	Brake type
		n ₂ .h 10000	n ₂ .h 25000	n ₂ .h 50000	n ₂ .h 100000	n ₂ .h 500000	n ₂ .h 1000000						
L1	3.7	10 000	9 600	9 400	9 300	6 000	4 850	75	18	1 500	3 000	3 200	6L
	4.2	10 000	9 600	9 400	9 300	6 000	4 850	75	18	1 500	3 000	3 200	6L
	4.9	9 500	8 500	7 800	7 800	5 700	4 600	75	18	1 500	3 000	2 600	6K
	5.8	8 500	7 200	6 500	6 500	5 700	4 650	75	18	1 500	3 000	2 100	6G
	7.1	7 000	5 900	5 500	5 500	4 700	3 850	60	18	1 500	3 000	1 500	6E
L2	13.5	10 000	9 600	9 400	9 300	6 000	4 850	40	13	1 750	3 500	1 000	5K
	17.6	10 000	9 600	9 400	9 300	6 000	4 850	40	13	1 750	3 500	1 000	5K
	21	10 000	9 600	9 400	9 300	6 000	4 850	40	13	1 750	3 500	800	5G
	24.7	9 500	8 500	7 800	7 800	5 700	4 600	30	13	1 750	3 500	400	5B
	28.9	8 500	7 200	6 500	6 500	5 700	4 650	26	13	1 750	3 500	400	5B
	32.2	8 500	7 200	6 500	6 500	5 700	4 650	24	13	1 750	3 500	400	5B
	39.5	8 500	7 200	6 500	6 500	5 700	4 650	22	13	1 750	3 500	400	5B
	48.4	7 000	5 900	5 500	5 500	4 700	3 850	16	13	1 750	3 500	400	5B
L3	45.7	10 000	9 600	9 400	9 300	6 000	4 850	21	7.5	1 750	3 500	330	4H
	59.6	10 000	9 600	9 400	9 300	6 000	4 850	16.5	7.5	1 750	3 500	260	4F
	78.2	10 000	9 600	9 400	9 300	6 000	4 850	13	7.5	1 750	3 500	260	4F
	102	10 000	9 600	9 400	9 300	6 000	4 850	11	7.5	1 750	3 500	160	4D
	143	9 500	8 500	7 800	7 800	5 700	4 600	9	7.5	1 750	3 500	160	4D
	167	8 500	7 200	6 500	6 500	5 700	4 650	6.9	7.5	1 750	3 500	100	4B
	186	8 500	7 200	6 500	6 500	5 700	4 650	6.2	7.5	1 750	3 500	100	4B
	232	8 500	7 200	6 500	6 500	5 700	4 650	5.1	7.5	1 750	3 500	100	4B
	284	8 500	7 200	6 500	6 500	5 700	4 650	4.2	7.5	1 750	3 500	50	4A
	348	7 000	5 900	5 500	5 500	4 700	3 850	2.8	7.5	1 750	3 500	50	4A
L4	203	10 000	9 600	9 400	9 300	6 000	4 850	8	6	1 750	3 500	100	4B
	264	10 000	9 600	9 400	9 300	6 000	4 850	6.2	6	1 750	3 500	100	4B
	344	10 000	9 600	9 400	9 300	6 000	4 850	4.9	6	1 750	3 500	50	4A
	451	10 000	9 600	9 400	9 300	6 000	4 850	3.8	6	1 750	3 500	50	4A
	586	10 000	9 600	9 400	9 300	6 000	4 850	2.9	6	1 750	3 500	50	4A
	731	10 000	9 600	9 400	9 300	6 000	4 850	2.4	6	1 750	3 500	50	4A
	822	9 500	8 500	7 800	7 800	5 700	4 600	1.7	6	1 750	3 500	50	4A
	1026	9 500	8 500	7 800	7 800	5 700	4 600	1.4	6	1 750	3 500	50	4A
	1202	8 500	7 200	6 500	6 500	5 700	4 650	1.1	6	1 750	3 500	50	4A
	1339	8 500	7 200	6 500	6 500	5 700	4 650	0.96	6	1 750	3 500	50	4A
	1671	8 500	7 200	6 500	6 500	5 700	4 650	0.8	6	1 750	3 500	50	4A
	2045	8 500	7 200	6 500	6 500	5 700	4 650	0.7	6	1 750	3 500	50	4A
2506	7 000	5 900	5 500	5 500	4 700	3 850	0.5	6	1 750	3 500	50	4A	

M_{2max}=1.2×Mn₂(n₂×h=10 000)

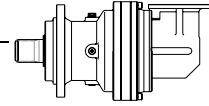

EP306R

M2'=8500N.m

	I 1:	Mn ₂ (N.m)						P ₁ (KW)	P _t (KW) (ta=20°C) (n ₁ =1500)	n ₁ (min ⁻¹)	n _{1max} (min ⁻¹)	M _b (N.m)	Brake type
		n ₂ .h 10000	n ₂ .h 25000	n ₂ .h 50000	n ₂ .h 100000	n ₂ .h 500000	n ₂ .h 1000000						
R2	9.4	6 500	5 600	5 100	4 200	2 600	2 150	35	18	1 750	3 500	440	4L
	10.7	7 000	5 900	5 500	5 500	4 700	3 850	35	18	1 750	3 500	440	4L
	12.7	9 500	8 500	7 800	7 800	5 700	4 600	35	18	1 750	3 500	440	4L
	14.8	8 500	7 200	6 500	6 500	5 700	4 650	35	18	1 750	3 500	440	4L
	18.2	7 000	5 900	5 500	5 500	4 700	3 850	35	18	1 750	3 500	440	4L
R3	27.7	10 000	9 600	9 400	9 300	6 000	4 850	35	14	1 750	3 500	440	4L
	36	10 000	9 600	9 400	9 300	6 000	4 850	27	14	1 750	3 500	400	4K
	43	10 000	9 600	9 400	9 300	6 000	4 850	23	14	1 750	3 500	400	4K
	50.7	9 500	8 500	7 800	7 800	5 700	4 600	19	14	1 750	3 500	330	4H
	59.3	8 500	7 200	6 500	6 500	5 700	4 650	16.5	14	1 750	3 500	330	4H
	66	8 500	7 200	6 500	6 500	5 700	4 650	15	14	1 750	3 500	260	4F
	80.9	8 500	7 200	6 500	6 500	5 700	4 650	13	14	1 750	3 500	160	4D
	99.1	7 000	5 900	5 500	5 500	4 700	3 850	9	14	1 750	3 500	100	4B
R4	93.6	10 000	9 600	9 400	9 300	6 000	4 850	14	12	1 750	3 500	160	4D
	122	10 000	9 600	9 400	9 300	6 000	4 850	11.3	12	1 750	3 500	160	4D
	160	10 000	9 600	9 400	9 300	6 000	4 850	9.5	12	1 750	3 500	100	4B
	208	10 000	9 600	9 400	9 300	6 000	4 850	7.5	12	1 750	3 500	100	4B
	292	9 500	8 500	7 800	7 800	5 700	4 600	4.8	12	1 750	3 500	50	4A
	342	8 500	7 200	6 500	6 500	5 700	4 650	3.2	12	1 750	3 500	50	4A
	381	8 500	7 200	6 500	6 500	5 700	4 650	2.9	12	1 750	3 500	50	4A
	476	8 500	7 200	6 500	6 500	5 700	4 650	2.4	12	1 750	3 500	50	4A
	582	8 500	7 200	6 500	6 500	5 700	4 650	2	12	1 750	3 500	50	4A
	714	7 000	5 900	5 500	5 500	4 700	3 850	1.5	12	1 750	3 500	50	4A

M_{2max}=1.2×Mn2(n2×h=10 000)

EP306L

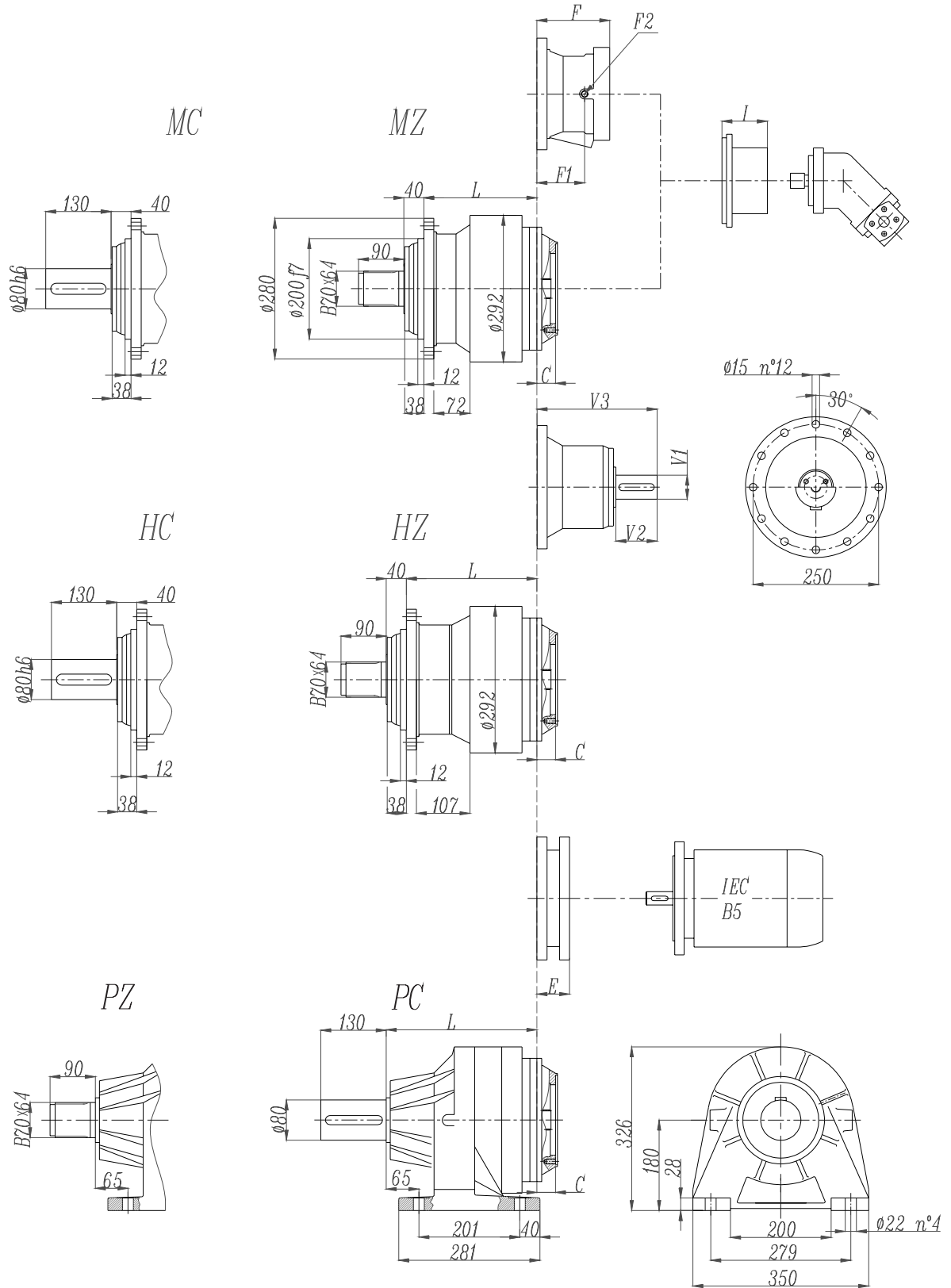

EP306L

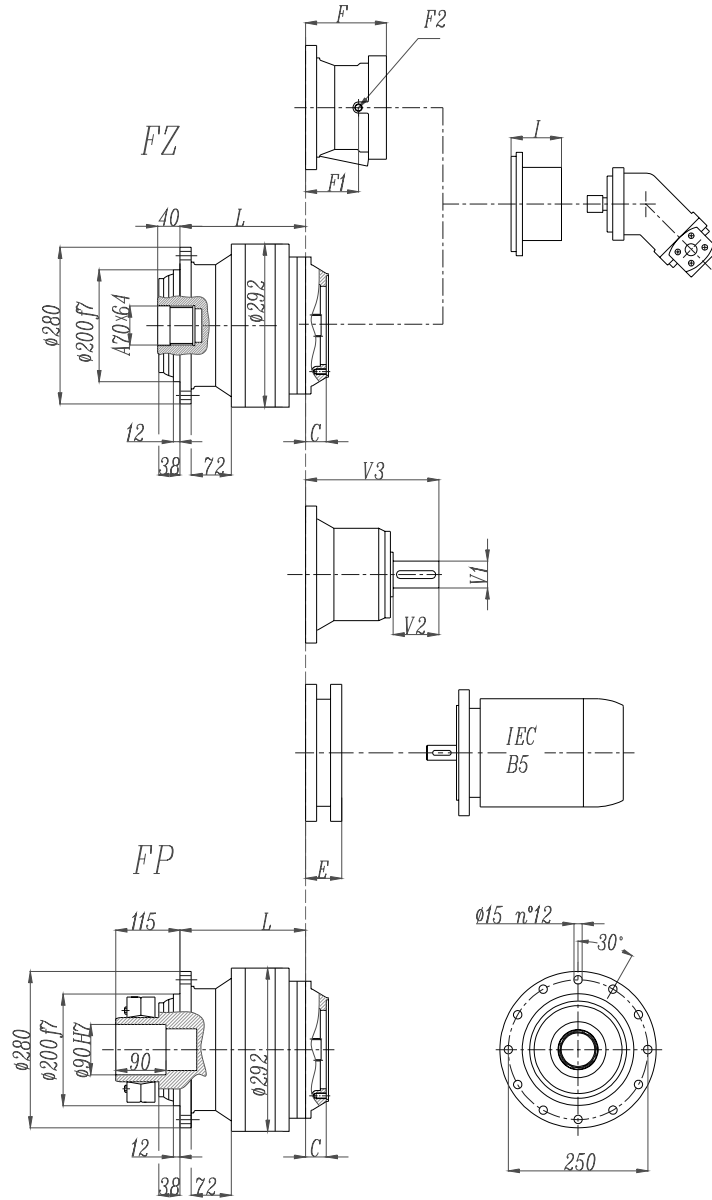

FP version
Max. transmissible
12000 N.m

	L				Ref. weight (without input) (Kg)				C	I	Brake				
	MZ MC	FZ FP	HZ HC	PC PZ	MZ MC	FZ FP	HZ HC	PC PZ			F	F1	F2	Type	Ref. Weight
306L1	160	160	195	235	65	65	70	80	45	According to hydraulic motor	195	147	1/4 G	6	35 Kg
306L2	229	229	264	304	74	74	79	89	37		145	95	1/4 G	5	22 Kg
306L3	282	282	317	357	78	78	83	93	37		105	65	1/4 G	4	15 Kg
306L4	335	335	370	410	82	82	87	97	37		105	65	1/4 G	4	15 Kg

	E (IEC motor input)													
	IEC 71	IEC 80	IEC 90	IEC 100	IEC 112	IEC 132	IEC 160	IEC 180	IEC 200	IEC 225	IEC 250			
306L1							152	152	182	212	193			
306L2	65	84	84	94	94	114	144							
306L3	65	84	84	94	94	114	144							
306L4	65	84	84	94	94	114	144							

EP306R

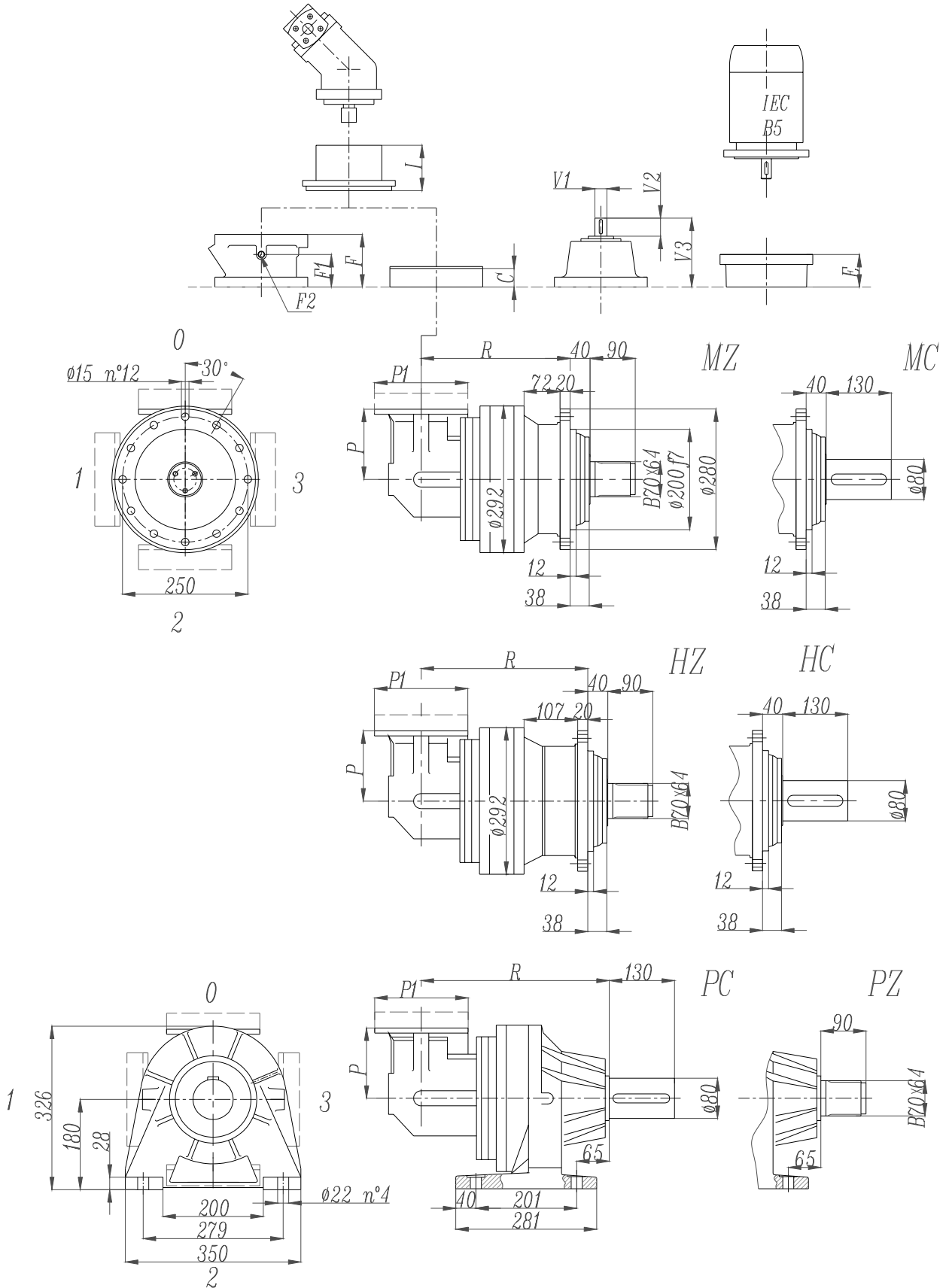

EP306R

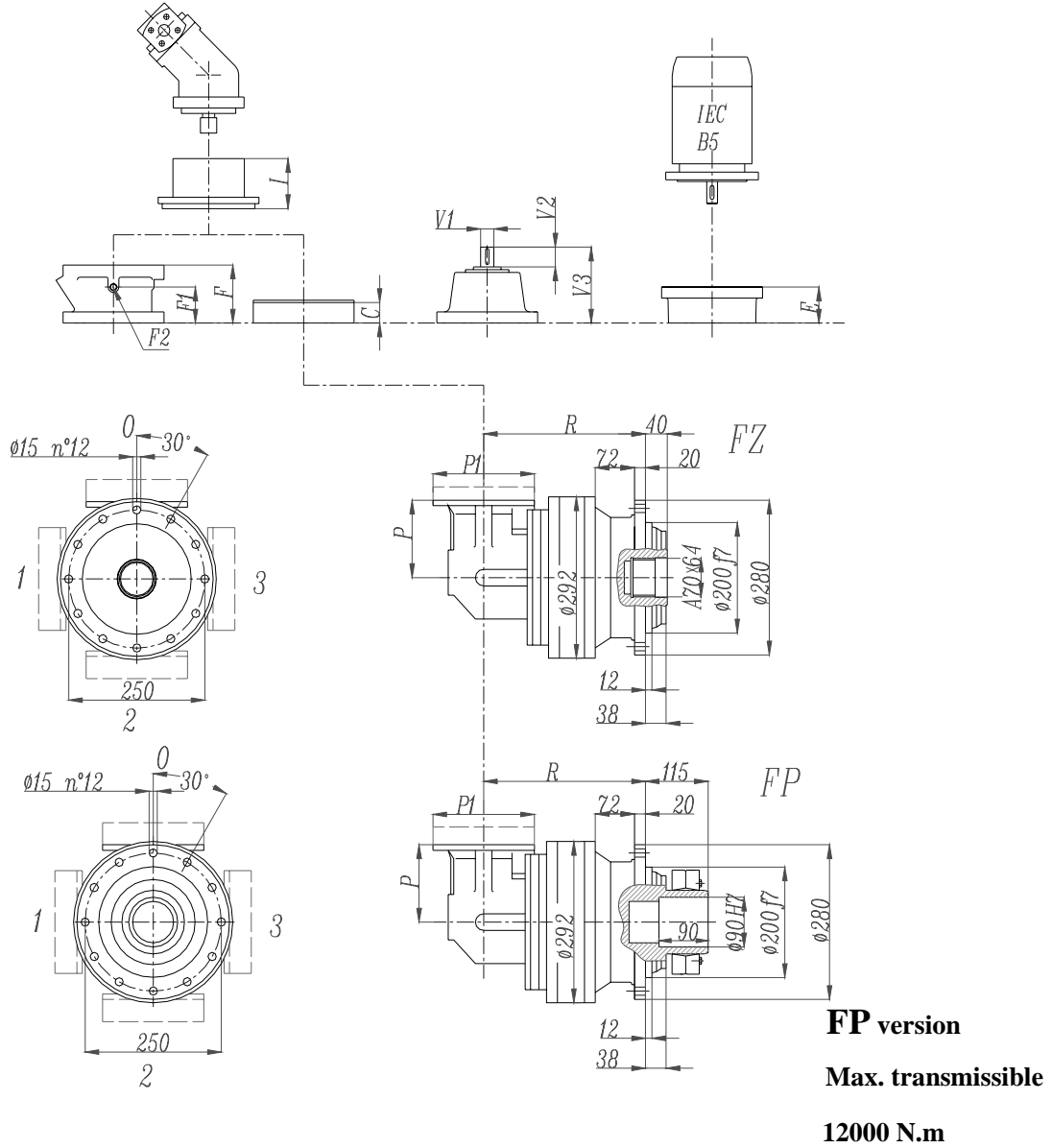

	R				Ref. weight (without input) (Kg)				C	P	I	Brake				
	MZ MC	FZ FP	HZ HC	PC PZ	MZ MC	FZ FP	HZ HC	PC PZ				F	F1	F2	Type	Ref. Weight
306R2	297	297	332	372	89	89	94	104	37	140	According to hydraulic motor	105	65	1/4 G	4	15 Kg
306R3	321	321	356	396	85	85	90	100	37	140		105	65	1/4 G	4	
306R4	374	374	409	449	79	79	84	94	37	122		105	65	1/4 G	4	

	P1	E (IEC motor input)						
		IEC71	IEC80	IEC90	IEC100	IEC112	IEC132	IEC160
306R2	186	65	84	84	94	94	114	144
306R3	186	65	84	84	94	94	114	144
306R4	186	65	84	84	94	94	114	144

EP306L - EP306R

MC-HC

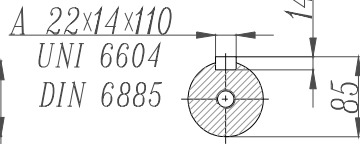
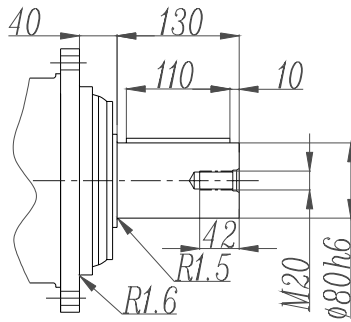

PC

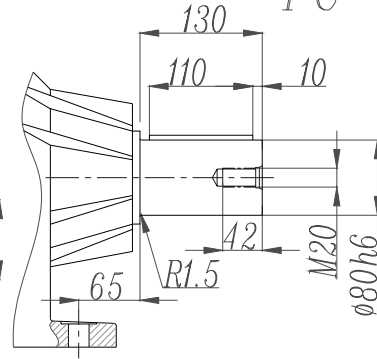

MZ-HZ

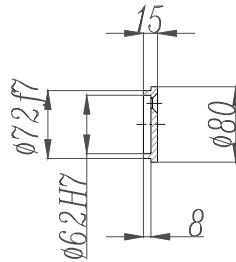
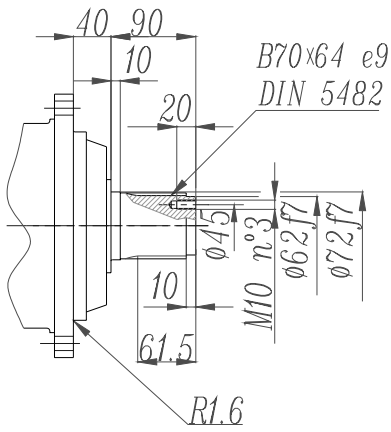

FZ

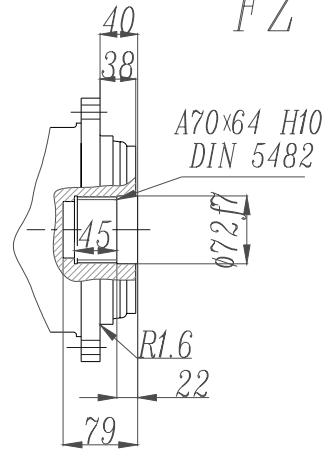

FP

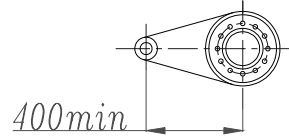
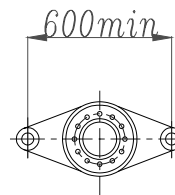
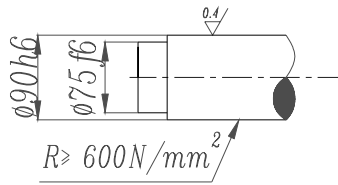
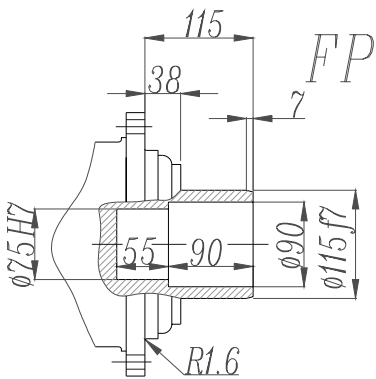

FP version

Max. transmissible

12000 N.m

EP306L - EP306R

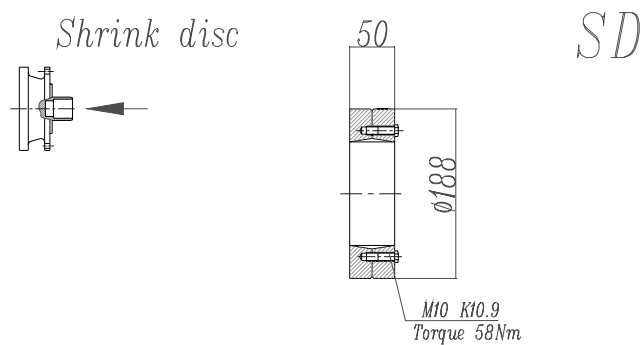
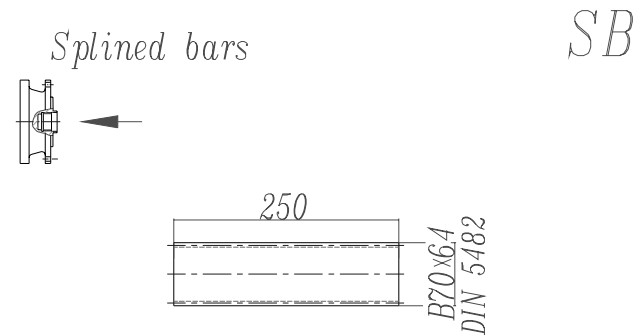
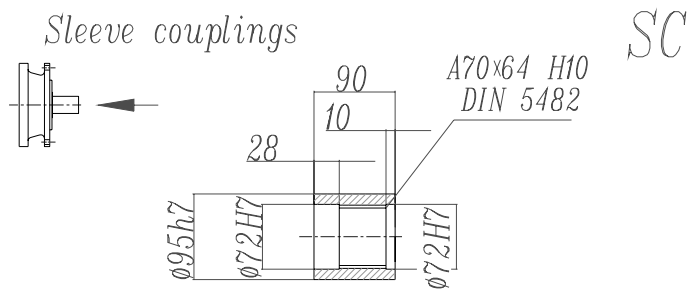
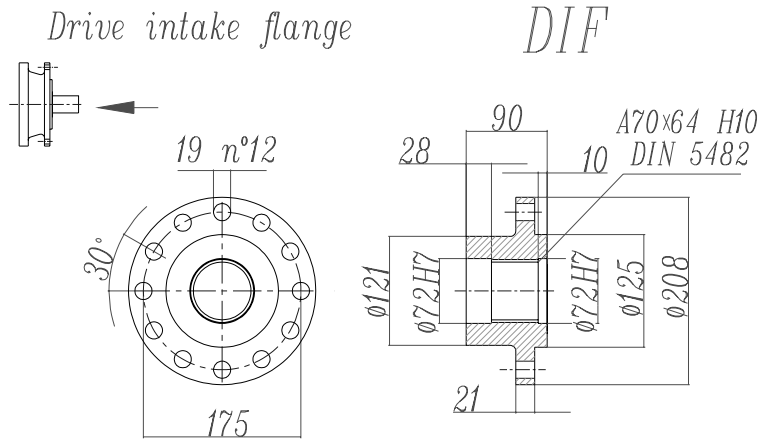

EP306L - EP306R

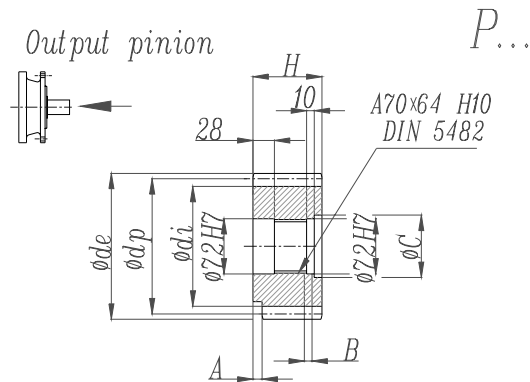

	m	z	x	dp	di	de	H	A	B	C
PFE1	8	15	0	120	100	134	90	0	0	0
PFE2	8	15	0.5000	120	108	141	90	0	0	0
PHB	10	11	0.500	110	95	136	90	10	0	0
PHC1	10	12	0.450	120	104	145	90	0	0	0
PHC2	10	12	0.320	120	100	144.2	90	0	0	0
PHC3	10	12	0.350	120	101	144	90	0	0	0
PHD1	10	13	0.950	130	124	165	90	0	0	0
PHD2	10	13	0.500	130	115	159	90	0	0	0
PHE1	10	14	0	140	115	160	90	0	0	0
PHE2	10	14	0.500	140	125	166	90	0	0	0
PHF	10	15	0	150	127	167	90	24	0	0
PHH	10	17	0.480	170	154	197.5	90	10	0	0
PHM	10	20	0	200	175	220	90	10	0	0

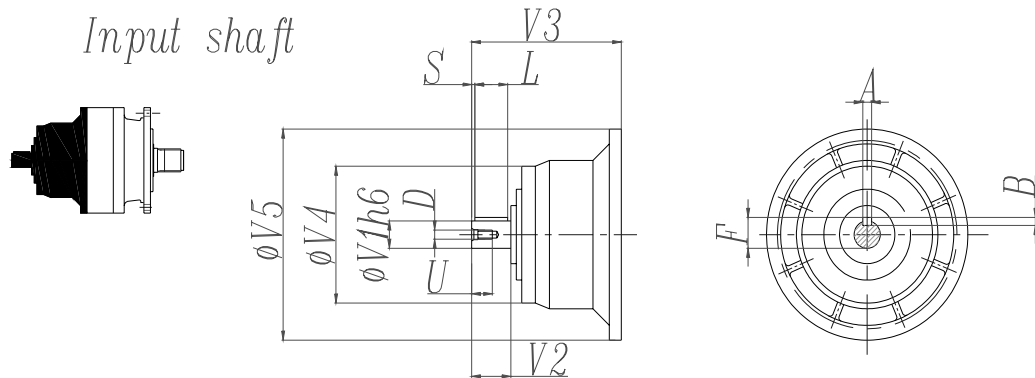

	CODE	V1	V2	V3	V4	V5	A	B	F	L	S	D	U
306L1	V06B	60	105	307	155	292	18	11	64	90	7.5	M16	36
306L2	V05B	48	82	239	155	245	14	9	51.5	70	6	M16	36
306L3	V01A	24	36	137.5	120	186	8	7	27	30	3	M8	19
	V01B	38	58	158	120	186	10	8	41	50	4	M12	28
306L4	V01A	24	36	137.5	120	186	8	7	27	30	3	M8	19
	V01B	38	58	158	120	186	10	8	41	50	4	M12	28
306R2-R3-R4	V01A	24	36	137.5	120	186	8	7	27	30	3	M8	19
	V01B	38	58	158	120	186	10	8	41	50	4	M12	28

EP306L - EP306R

Permissible radial and axial loads on output shaft with Fh2 ($n_2 \cdot h=10\ 000$)

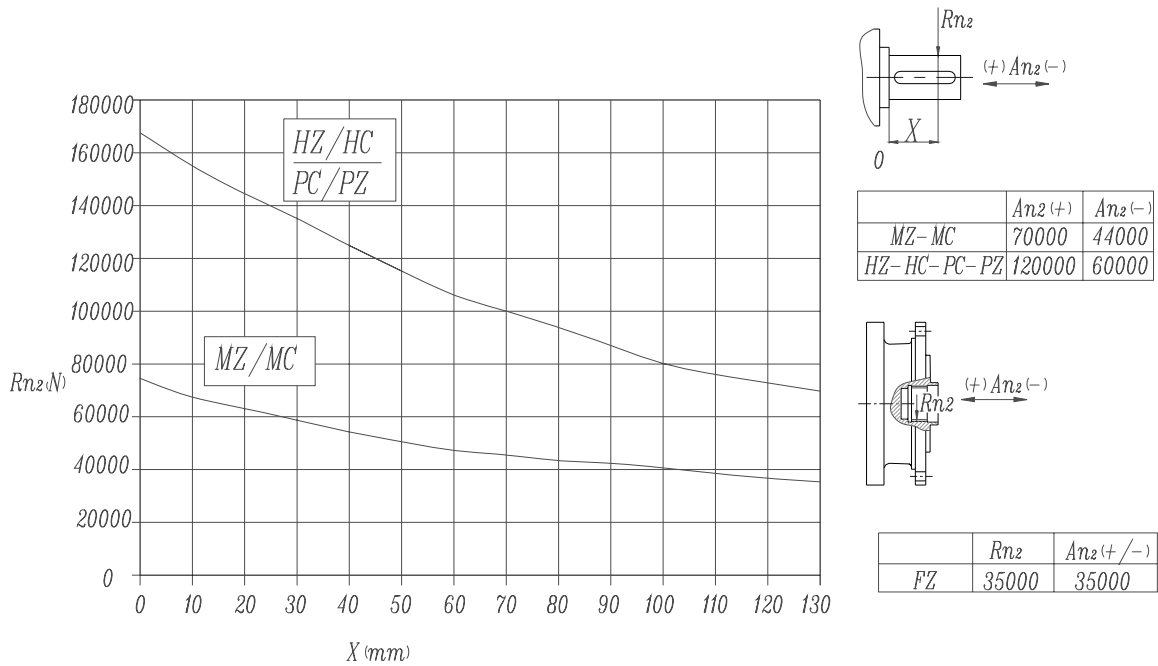

Load corrective factor fh2 on shafts	fh2= $n_2 \cdot h$		10 000	25 000	50 000	100 000	500 000	1 000 000
	fh2	MZ-MC-PC-PZ-FZ	1	0.74	0.58	0.46	0.27	0.21
		HZ-HC	1	0.76	0.61	0.50	0.31	0.25

Permissible radial loads on input shaft with Fh1 ($n_1 \cdot h=250\ 000$)

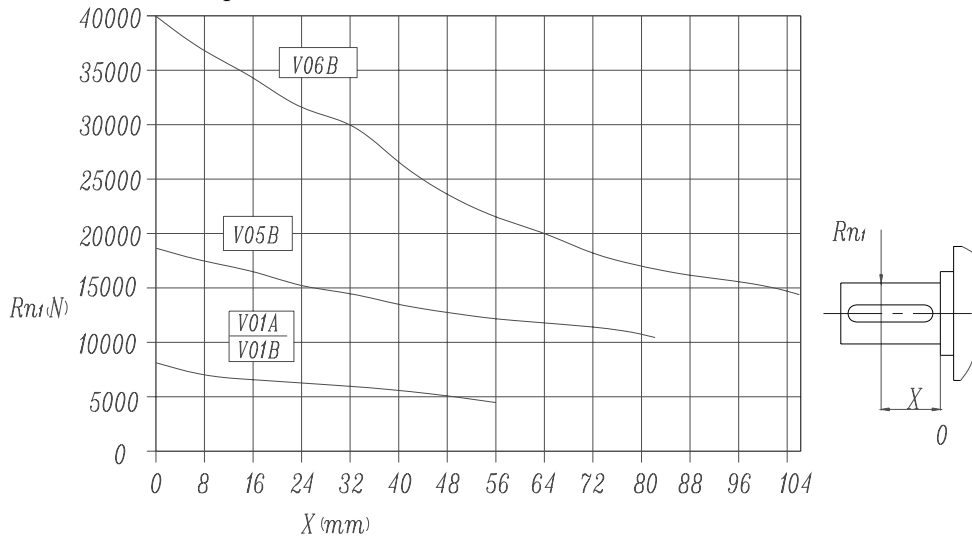

Load corrective factor fh1 on shafts	Fh1= $n_1 \cdot h$		250 000	500 000	1 000 000	2 00 000	5 000 000	10 000 000
	fh1		1	0.79	0.63	0.50	0.37	0.29

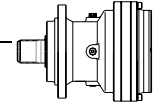

EP307L

M2'=12500N.m

	I 1:	Mn ₂ (N.m)						P ₁ (KW)	P _t (KW) (ta=20°C) (n ₁ =1500)	n ₁ (min ⁻¹)	n _{1max} (min ⁻¹)	M _b (N.m)	Brake type
		n ₂ .h 10000	n ₂ .h 25000	n ₂ .h 50000	n ₂ .h 100000	n ₂ .h 500000	n ₂ .h 1000000						
L1	3.4	15 000	13 800	12 900	12 500	7 900	6 400	100	22	1 500	2 500	3 200	6L
	4.4	15 000	13 800	12 900	12 500	7 900	6 400	100	22	1 500	2 500	3 200	6L
	5.3	14 000	12 000	10 700	10 500	7 700	6 200	100	22	1 500	2 500	3 200	6L
	6.2	11 000	9 600	8 700	8 700	7 700	6 200	100	22	1 500	2 500	2 100	6K
L2	12.6	15 000	13 800	12 900	12 500	7 900	6 400	60	18	1 750	3 500	1 000	5K
	16.1	15 000	13 800	12 900	12 500	7 900	6 400	60	18	1 750	3 500	1 000	5K
	18.5	15 000	13 800	12 900	12 500	7 900	6 400	60	18	1 750	3 500	1 000	5K
	22	15 000	13 800	12 900	12 500	7 900	6 400	55	18	1 750	3 500	1 000	5K
	26.3	14 000	12 000	10 700	10 500	7 700	6 200	50	18	1 750	3 500	800	5G
	29.2	14 000	12 000	10 700	10 500	7 700	6 200	45	18	1 750	3 500	630	5E
	35.8	14 000	12 000	10 700	10 500	7 700	6 200	37	18	1 750	3 500	500	5C
	42.5	11 000	9 600	8 700	8 700	7 700	6 200	32	18	1 750	3 500	400	5B
	L3	42.5	15 000	13 800	12 900	12 500	7 900	6 400	35	11	1 750	3 500	400
54.6		15 000	13 800	12 900	12 500	7 900	6 400	28	11	1 750	3 500	330	4H
62.5		15 000	13 800	12 900	12 500	7 900	6 400	25	11	1 750	3 500	330	4H
82.1		15 000	13 800	12 900	12 500	7 900	6 400	20	11	1 750	3 500	260	4F
107		15 000	13 800	12 900	12 500	7 900	6 400	16	11	1 750	3 500	160	4D
127		15 000	13 800	12 900	12 500	7 900	6 400	14	11	1 750	3 500	160	4D
151		14 000	12 000	10 700	10 500	7 700	6 200	11.8	11	1 750	3 500	160	4D
169		14 000	12 000	10 700	10 500	7 700	6 200	10	11	1 750	3 500	100	4B
211		14 000	12 000	10 700	10 500	7 700	6 200	8	11	1 750	3 500	100	4B
258		14 000	12 000	10 700	10 500	7 700	6 200	7	11	1 750	3 500	100	4B
306	11 000	9 600	8 700	8 700	7 700	6 200	5	11	1 750	3 500	50	4A	
L4	278	15 000	13 800	12 900	12 500	7 900	6 400	6	7.5	1 750	3 500	50	4A
	365	15 000	13 800	12 900	12 500	7 900	6 400	5	7.5	1 750	3 500	50	4A
	474	15 000	13 800	12 900	12 500	7 900	6 400	4	7.5	1 750	3 500	50	4A
	591	15 000	13 800	12 900	12 500	7 900	6 400	3.3	7.5	1 750	3 500	50	4A
	768	15 000	13 800	12 900	12 500	7 900	6 400	2.6	7.5	1 750	3 500	50	4A
	914	15 000	13 800	12 900	12 500	7 900	6 400	2.2	7.5	1 750	3 500	50	4A
	1090	14 000	12 000	10 700	10 500	7 700	6 200	2	7.5	1 750	3 500	50	4A
	1215	14 000	12 000	10 700	10 500	7 700	6 200	1.7	7.5	1 750	3 500	50	4A
	1516	14 000	12 000	10 700	10 500	7 700	6 200	1.2	7.5	1 750	3 500	50	4A
	1856	14 000	12 000	10 700	10 500	7 700	6 200	1	7.5	1 750	3 500	50	4A
2202	11 000	9 600	8 700	8 700	7 700	6 200	0.8	7.5	1 750	3 500	50	4A	

M_{2max}=1.2×Mn₂(n₂×h=10 000)

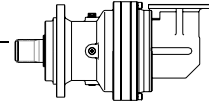

EP307R

M2'=12500N.m

	I	Mn ₂ (N.m)						P ₁ (KW)	P _t (KW) (ta=20°C) (n ₁ =1500)	n ₁ (min ⁻¹)	n _{1max} (min ⁻¹)	M _b (N.m)	Brake type
		n ₂ .h 10000	n ₂ .h 25000	n ₂ .h 50000	n ₂ .h 100000	n ₂ .h 500000	n ₂ .h 1000000						
R2	13	9 100	8 500	7 600	6 800	5 500	4 400	60	35	1 750	3 500	1000	5K
	16.7	11 000	9 800	8 900	12 500	7 900	6 400	50	35	1 750	3 500	800	5G
	19.9	14 000	12 000	10 700	10 500	7 700	6 200	45	35	1 750	3 500	800	5G
	23.6	11 000	9 600	8 700	8 700	7 700	6 200	42	35	1 750	3 500	800	5G
R3	32.2	9 100	8 500	7 600	6 800	5 500	4 400	30	20	1 750	3 500	400	4K
	41.3	11 000	9 800	8 900	12 500	7 900	6 400	28	20	1 750	3 500	400	4K
	47.4	14 000	12 000	10 700	10 500	7 700	6 200	25	20	1 750	3 500	400	4K
	56.4	15 000	13 800	12 900	12 500	7 900	6 400	22	20	1 750	3 500	330	4H
	67.3	14 000	12 000	10 700	10 500	7 700	6 200	20	20	1 750	3 500	330	4H
	75	14 000	12 000	10 700	10 500	7 700	6 200	18	20	1 750	3 500	260	4F
	91.8	14 000	12 000	10 700	10 500	7 700	6 200	15	20	1 750	3 500	260	4F
	109	11 000	9 600	8 700	8 700	7 700	6 200	12	20	1 750	3 500	160	4D
R4	112	15 000	13 800	12 900	12 500	7 900	6 400	12	14	1 750	3 500	160	4D
	128	15 000	13 800	12 900	12 500	7 900	6 400	11	14	1 750	3 500	160	4D
	168	15 000	13 800	12 900	12 500	7 900	6 400	9	14	1 750	3 500	160	4D
	219	15 000	13 800	12 900	12 500	7 900	6 400	7	14	1 750	3 500	100	4B
	260	15 000	13 800	12 900	12 500	7 900	6 400	6	14	1 750	3 500	100	4B
	310	14 000	12 000	10 700	10 500	7 700	6 200	5.5	14	1 750	3 500	100	4B
	346	14 000	12 000	10 700	10 500	7 700	6 200	5	14	1 750	3 500	100	4B
	433	14 000	12 000	10 700	10 500	7 700	6 200	4	14	1 750	3 500	50	4A
	529	14 000	12 000	10 700	10 500	7 700	6 200	3.3	14	1 750	3 500	50	4A
	627	11 000	9 600	8 700	8 700	7 700	6 200	2.5	14	1 750	3 500	50	4A

M_{2max}=1.2×Mn₂(n₂×h=10 000)

EP307L

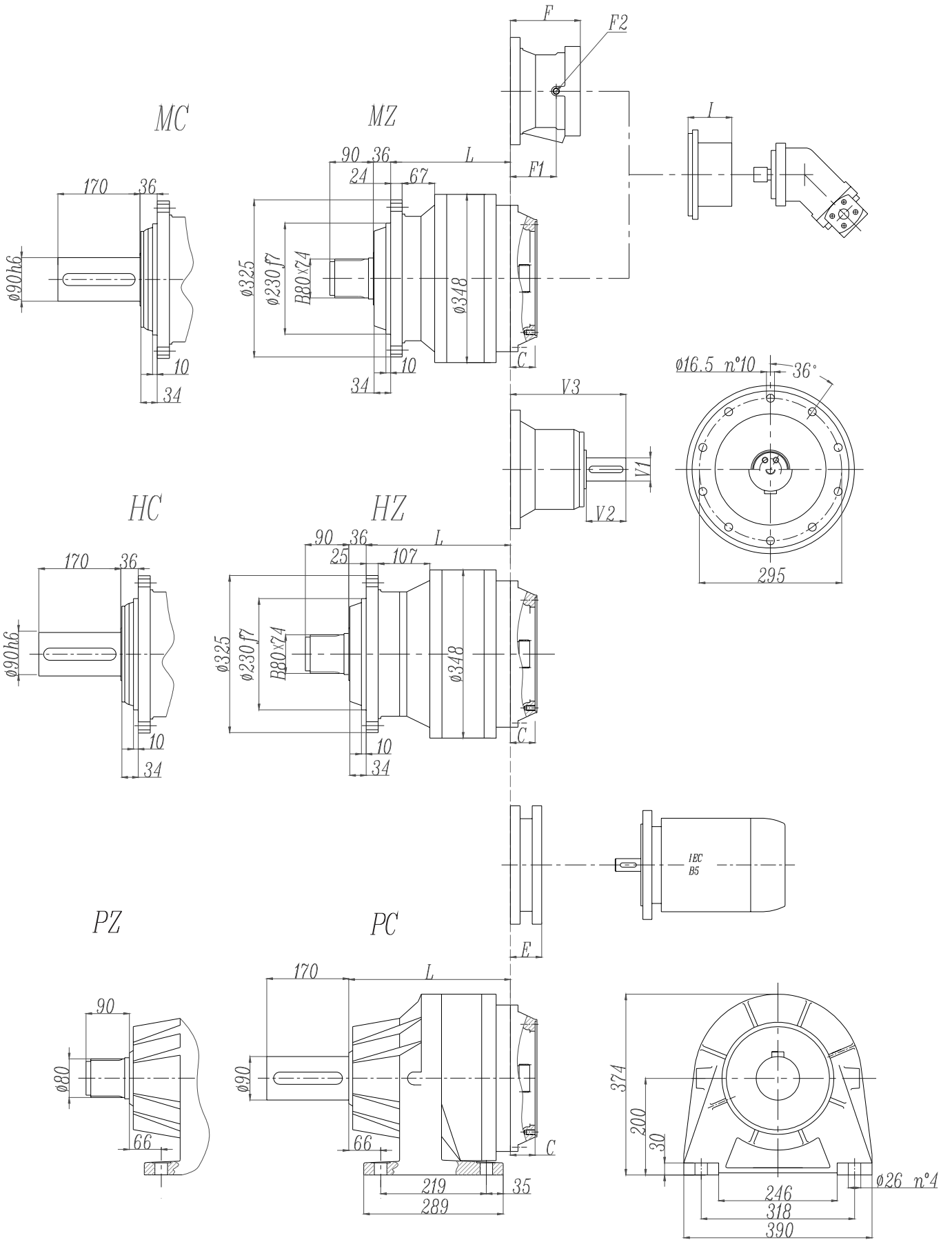

EP307L

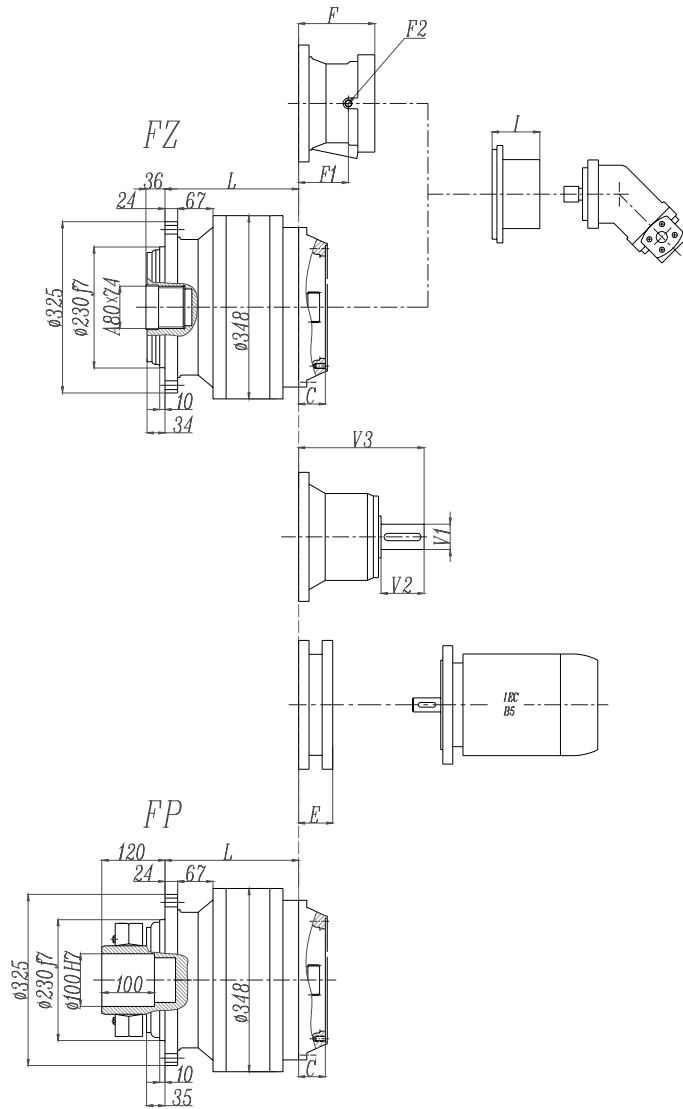

FP version
Max. transmissible
18000 N.m

	L				Ref. weight (without input) (Kg)				C	I	Brake				
	MZ MC	FZ FP	HZ HC	PC PZ	MZ MC	FZ FP	HZ HC	PC PZ			F	F1	F2	Type	Ref. Weight
307L1	165	165	210	246	95	85	105	120	51	According to hydraulic motor	201	153	1/4 G	6	38 Kg
307L2	258	258	303	339	107	97	117	132	37		145	95	1/4 G	5	22 Kg
307L3	323	323	368	404	114	104	124	139	37		105	65	1/4 G	4	15 Kg
307L4	376	376	421	457	118	108	128	143	37		105	65	1/4 G	4	15 Kg

	E (IEC motor input)												
	IEC 71	IEC 80	IEC 90	IEC 100	IEC 112	IEC 132	IEC 160	IEC 180	IEC 200	IEC 225	IEC 250		
307L1								195	186	216	216		
307L2	65	84	84	94	94	114	144						
307L3	65	84	84	94	94	114	144						
307L4	65	84	84	94	94	114	144						

EP307R

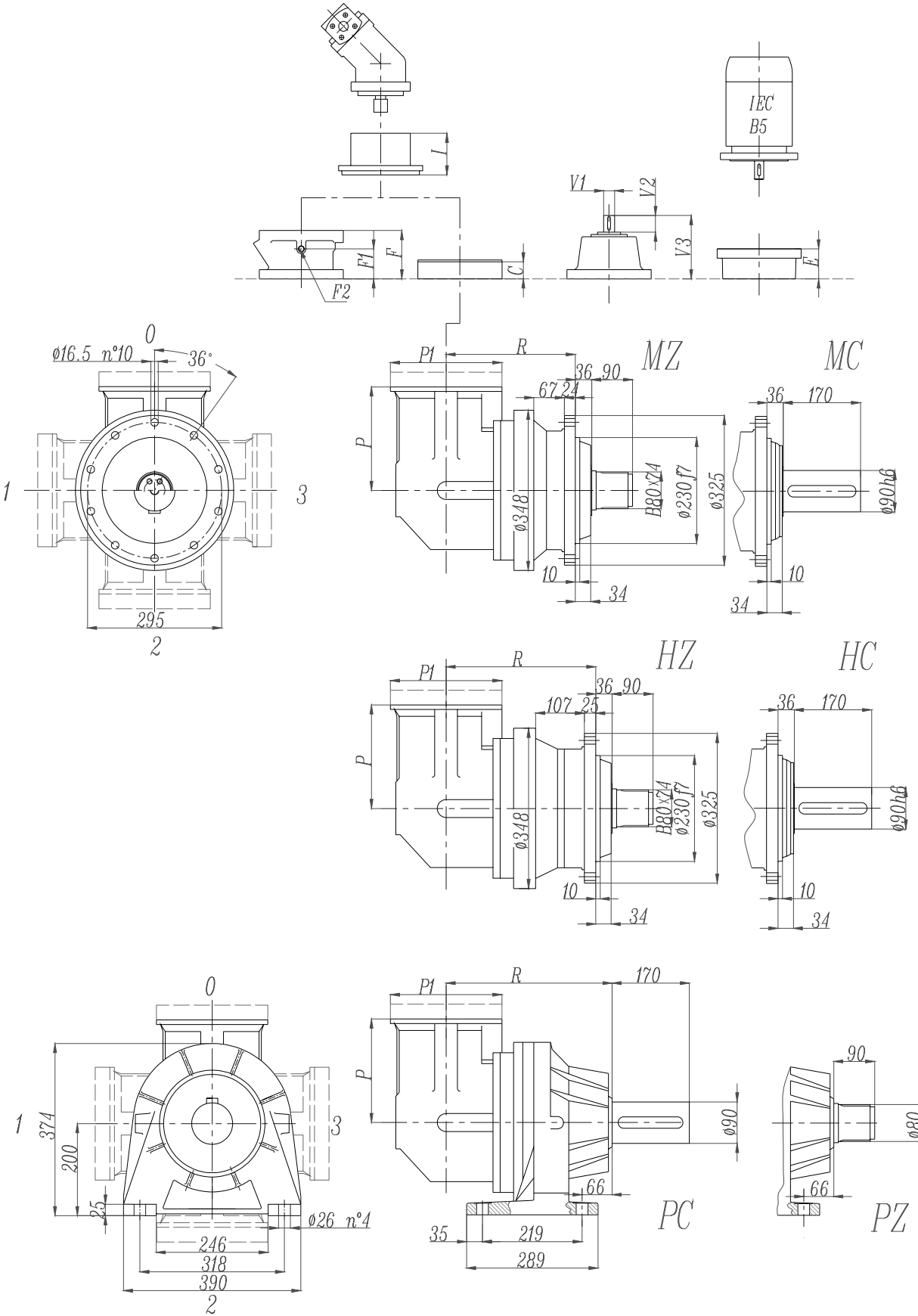

EP307R

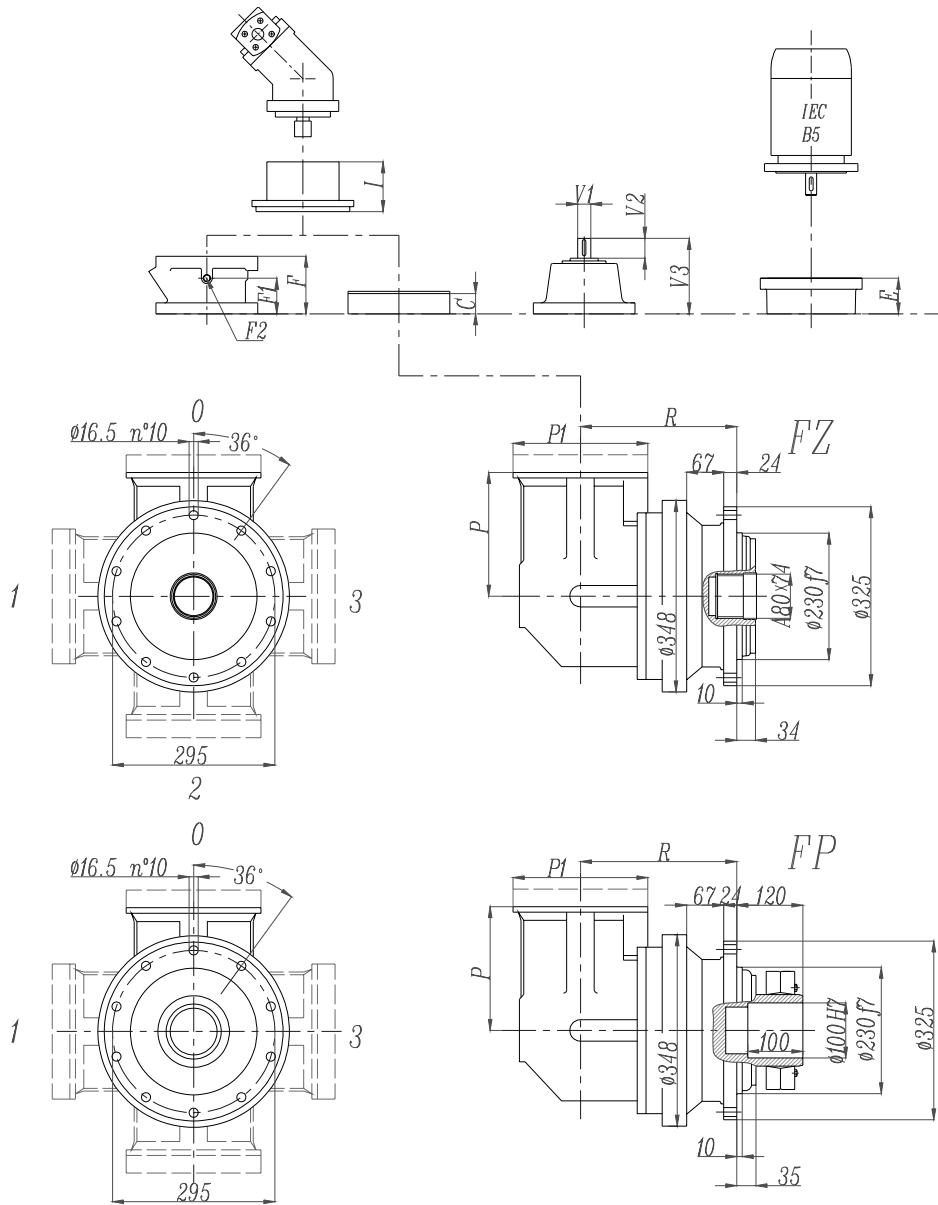

FP version
Max. transmissible
18000 N.m

	2				Ref. weight (without input) (Kg)				C	P	I	Brake				
	MZ MC	FZ FP	HZ HC	PC PZ	MZ MC	FZ FP	HZ HC	PC PZ				F	F1	F2	Type	Ref. Weight 15 Kg
307R2	284	284	329	365	145	135	155	170	37	225	According to hydraulic motor	145	95	1/4 G	4	22
307R3	350	350	395	431	127	117	137	152	37	140		105	65	1/4 G	4	15
307R4	415	415	460	496	128	118	138	153	37	122		105	65	1/4 G	4	15

	P1	E (IEC motor input)									
		IEC 71	IEC 80	IEC 90	IEC 100	IEC 112	IEC 132	IEC 160	IEC 180	IEC 200	
307R2	245	65	84	84	94	94	114	144	144	174	
307R3	186	65	84	84	94	94	114	144			
307R4	186	65	84	84	94	94	114	144			

EP307L - EP307R

MC-HC

PC

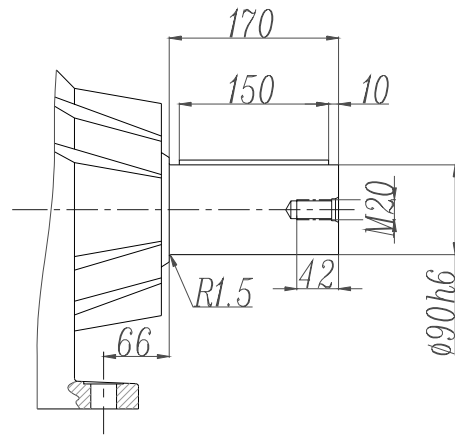
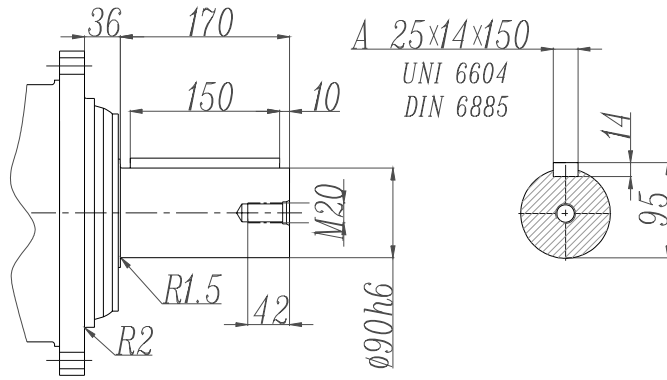

MZ-HZ

FZ

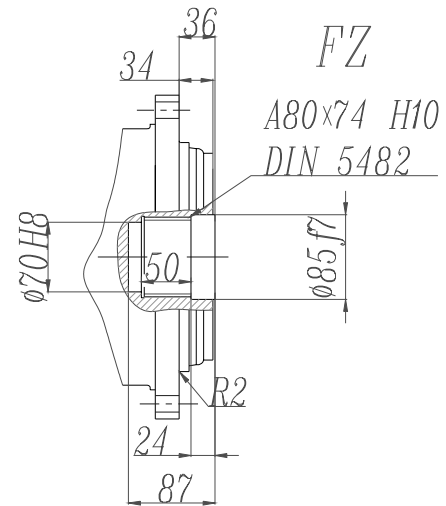
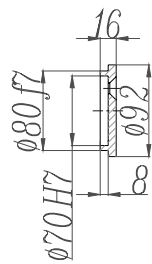
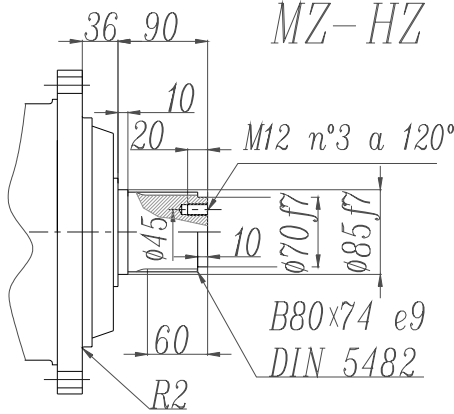

FP

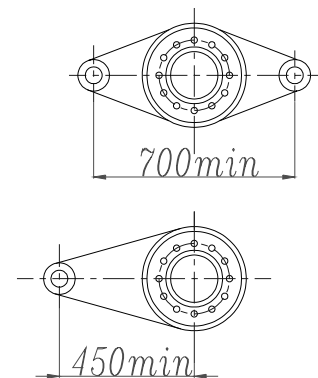
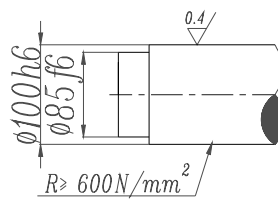
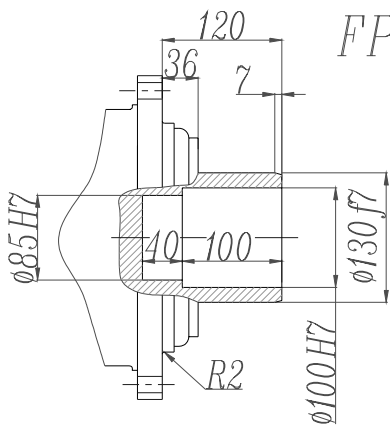

FP version

Max. transmissible

18000 N.m

EP307L - EP307R

Drive intake flange

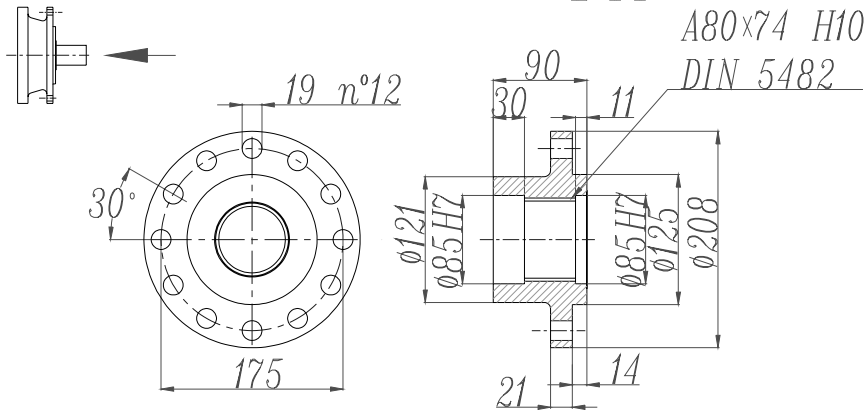

Sleeve couplings

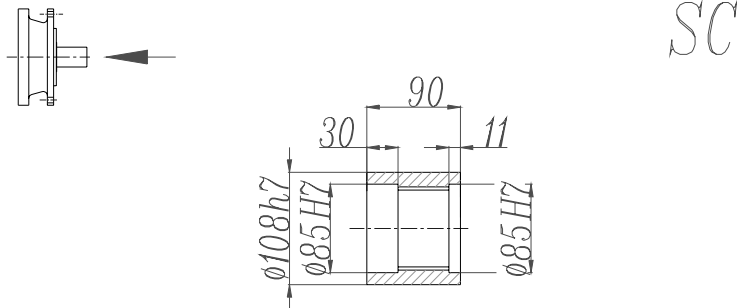

Splined bars

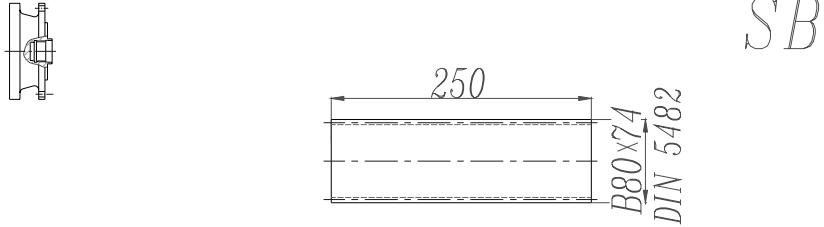

Shrink disc

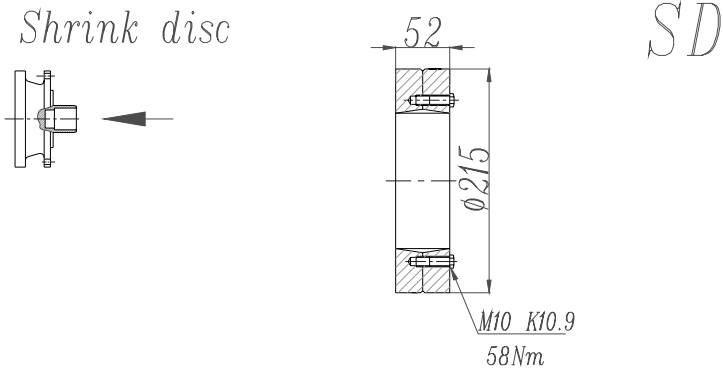

EP307L - EP307R

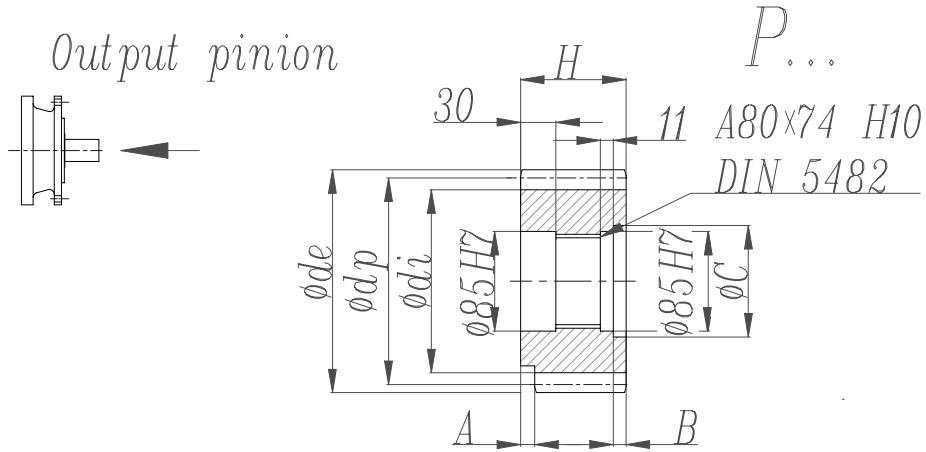

	m	z	x	dp	di	de	H	A	B	C
PFG	8	16	0.5000	128	117	149.5	90	0	0	0
PHC	10	12	0.4500	120	104	145	90	0	0	0
PHE	10	14	0.320	140	121	162.5	116	13	26	95
PHF	10	15	0.150	150	130	171.5	107	20	17	100
PHG	10	16	0.500	160	145	186	90	10	0	0
PHH1	10	17	0	170	145	190	90	0	0	0
PHH2	10	17	0.500	170	154	198	90	0	0	0
PLD	12	13	0.500	156	138	192	102	0	12	95
PLE	12	14	0.500	168	150	199.2	90	0	0	0
PLI	12	18	0.500	216	198	249.6	107	7	17	95
PLT	12	26	0	312	282	336	90	0	0	0

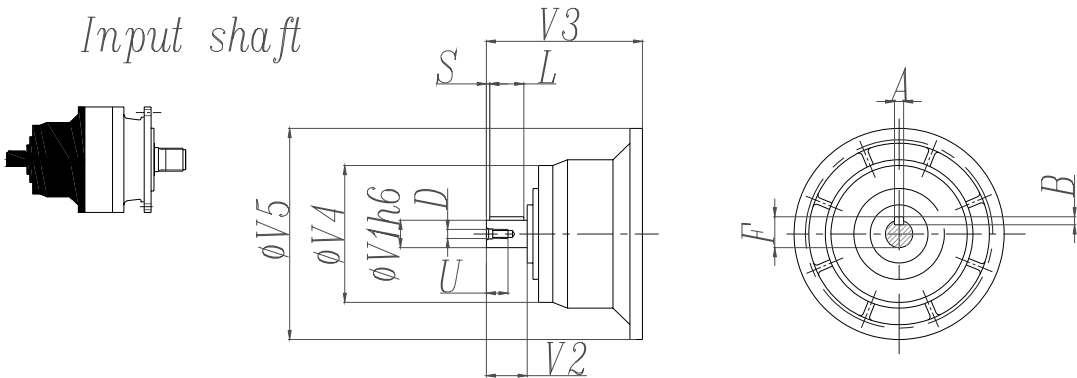

	CODE	V1	V2	V3	V4	V5	A	B	F	L	S	D	U
307L1	V07B	80	130	315	200	345	22	14	85	110	10	M16	36
	V07A	60	105	313	155	345	18	11	64	90	7.5	M16	36
307L2	V05B	48	82	239	155	245	14	9	51.5	70	6	M16	36
307L3	V01A	24	36	137.5	120	186	8	7	27	30	3	M8	19
	V01B	38	58	158	120	186	10	8	41	50	4	M12	28
307L4	V01A	24	36	137.5	120	186	8	7	27	30	3	M8	19
	V01B	38	58	158	120	186	10	8	41	50	4	M12	28
307R2	V05B	48	82	239	155	245	14	9	51.5	70	6	M16	36
307 R3-R4	V01A	24	36	137.5	120	186	8	7	27	30	3	M8	19
	V01B	38	58	158	120	186	10	8	41	50	4	M12	28

EP307L - EP307R

Permissible radial and axial loads on output shaft with Fh2 ($n_2 \cdot h=10\ 000$)

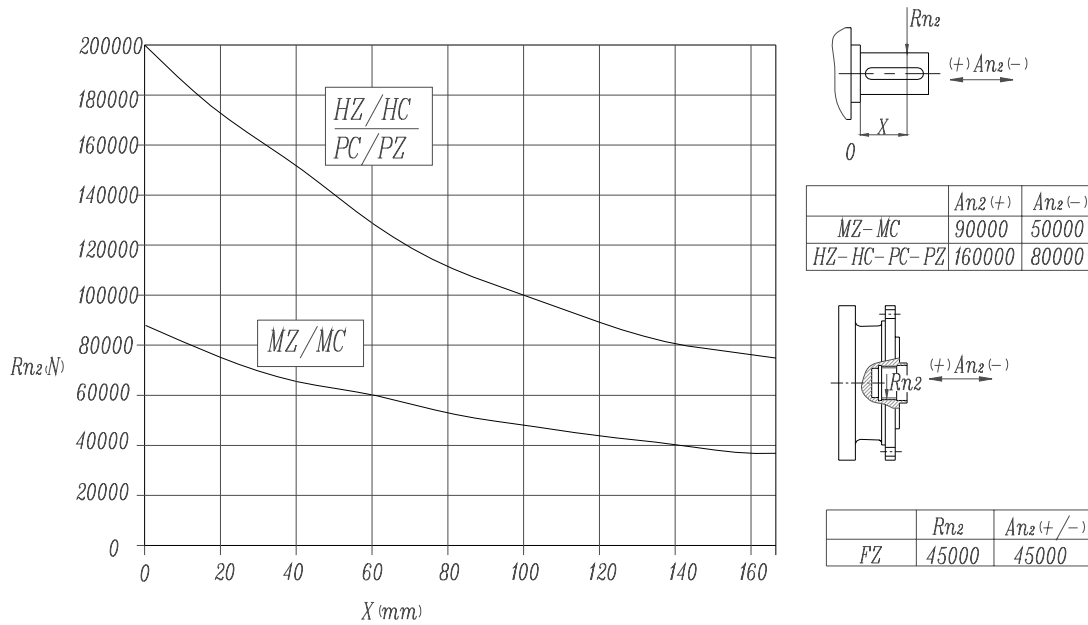

Load corrective factor fh2 on shafts	fh2= $n_2 \cdot h$		10 000	25 000	50 000	100 000	500 000	1 000 000	
	fh2	MZ-MC-PC-PZ-FZ		1	0.74	0.58	0.46	0.27	0.21
		HZ-HC		1	0.76	0.61	0.50	0.31	0.25

Permissible radial loads on input shaft with Fh1 ($n_1 \cdot h=250\ 000$)

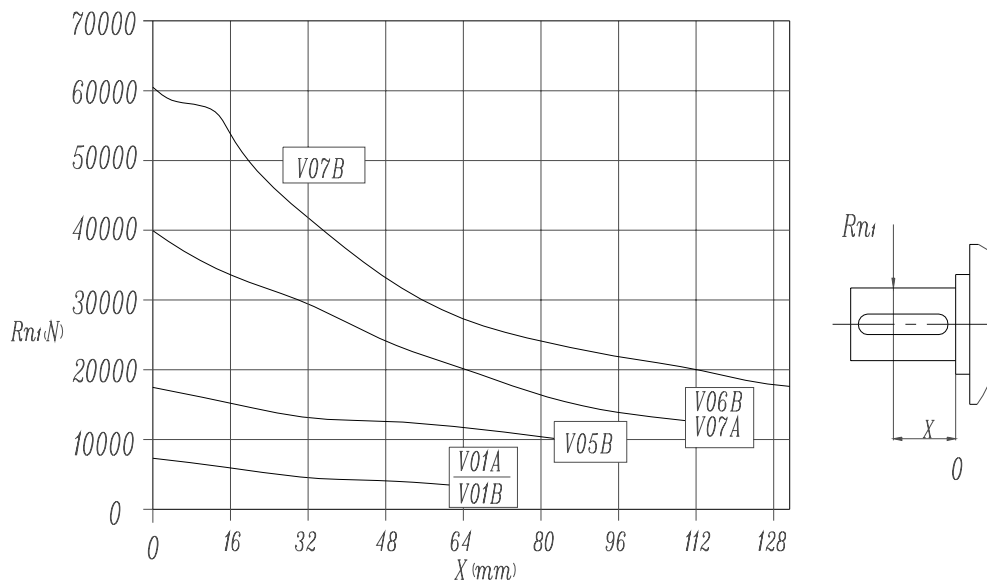

Load corrective factor fh1 on shafts	Fh1= $n_1 \cdot h$	250 000	500 000	1 000 000	2 00 000	5 000 000	10 000 000
	fh1	1	0.79	0.63	0.50	0.37	0.29

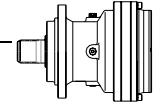

EP309L

M2'=18500N.m

	I 1:	Mn ₂ (N.m)						P ₁ (KW)	P _t (KW) (ta=20°C) (n ₁ =1500)	n ₁ (min ⁻¹)	n _{1max} (min ⁻¹)	M _b (N.m)	Brake type
		n ₂ .h 10000	n ₂ .h 25000	n ₂ .h 50000	n ₂ .h 100000	n ₂ .h 500000	n ₂ .h 1000000						
L1	3.4	22 500	20 600	19 000	16 800	10 400	8 400	130	25	1 500	2 000	3 200	6L
	4.4	22 500	20 600	19 000	16 800	10 400	8 400	130	25	1 500	2 000	3 200	6L
	5.3	21 000	18 100	16 200	16 000	10 700	8 700	130	25	1 500	2 000	3 200	6L
	6.2	17 000	14 400	13 000	13 000	10 400	8 500	130	25	1 500	2 000	3 200	6L
L2	12.6	18 000	17 500	16 500	15 200	9 400	7 600	60	18	1 750	3 500	1 000	5K
	16.1	21 300	20 600	19 000	15 600	9 600	7 800	60	18	1 750	3 500	1 000	5K
	18.5	21 300	20 600	19 000	15 600	9 600	7 800	60	18	1 750	3 500	1 000	5K
	22	18 000	17 500	16 500	15 200	9 400	7 600	60	18	1 750	3 500	1 000	5K
	26.3	21 000	18 100	16 200	16 000	10 700	8 700	60	18	1 750	3 500	1000	5K
	29.2	18 000	17 500	16 500	15 200	9 400	7 600	60	18	1 750	3 500	1000	5K
	35.8	17 000	14 400	13 000	13 000	10 400	8 500	57	18	1 750	3 500	800	5E
	42.5	17 000	14 400	13 000	13 000	10 400	8 500	42	18	1 750	3 500	500	5C
	L3	42.5	18 000	17 500	16 500	15 200	9 400	7 600	42	11	1 750	3 500	440
54.6		21 300	20 600	19 000	15 600	9 600	7 800	36	11	1 750	3 500	440	4L
62.5		21 300	20 600	19 000	15 600	9 600	7 800	33	11	1 750	3 500	400	4K
82.1		21 300	20 600	19 000	15 600	9 600	7 800	28	11	1 750	3 500	330	4H
107		21 300	20 600	19 000	15 600	9 600	7 800	23	11	1 750	3 500	260	4F
127		18 000	17 500	16 500	15 200	9 400	7 600	20	11	1 750	3 500	260	4F
151		21 000	18 100	16 200	16 000	10 700	8 700	17	11	1 750	3 500	160	4D
169		18 000	17 500	16 500	15 200	9 400	7 600	16	11	1 750	3 500	160	4D
211		18 000	17 500	16 500	15 200	9 400	7 600	13	11	1 750	3 500	100	4B
258		17 000	14 400	13 000	13 000	10 400	8 500	8	11	1 750	3 500	100	4B
306	17 000	14 400	13 000	13 000	10 400	8 500	7	11	1 750	3 500	100	4B	
L4	278	21 300	20 600	19 000	15 600	9 600	7 800	10	7.5	1 750	3 500	100	4B
	365	21 300	20 600	19 000	15 600	9 600	7 800	8	7.5	1 750	3 500	100	4B
	474	21 300	20 600	19 000	15 600	9 600	7 800	6.5	7.5	1 750	3 500	50	4A
	591	21 300	20 600	19 000	15 600	9 600	7 800	5.5	7.5	1 750	3 500	50	4A
	768	21 300	20 600	19 000	15 600	9 600	7 800	4.5	7.5	1 750	3 500	50	4A
	914	21 000	18 100	16 200	16 000	10 700	8 700	3.3	7.5	1 750	3 500	50	4A
	1090	18 000	17 500	16 500	15 200	9 400	7 600	2.7	7.5	1 750	3 500	50	4A
	1215	18 000	17 500	16 500	15 200	9 400	7 600	2.5	7.5	1 750	3 500	50	4A
	1516	18 000	17 500	16 500	15 200	9 400	7 600	2.1	7.5	1 750	3 500	50	4A
	1856	17 000	14 400	13 000	13 000	10 400	8 500	1.6	7.5	1 750	3 500	50	4A
2202	17 000	14 400	13 000	13 000	10 400	8 500	1.4	7.5	1 750	3 500	50	4A	

M_{2max}=1.2×Mn₂(n₂×h=10 000)

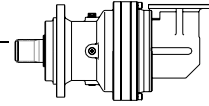

EP309R

M2'=18500N.m

	I	Mn ₂ (N.m)						P ₁ (KW)	P _t (KW) (ta=20°C) (n ₁ =1500)	n ₁ (min ⁻¹)	n _{1max} (min ⁻¹)	M _b (N.m)	Brake type
		n ₂ .h 10000	n ₂ .h 25000	n ₂ .h 50000	n ₂ .h 100000	n ₂ .h 500000	n ₂ .h 1000000						
R2	13	9 100	8 500	7 600	6 800	5 500	4 400	60	35	1 750	3 500	1000	5K
	16.7	11 000	9 800	8 900	12 500	7 900	6 400	50	35	1 750	3 500	1000	5K
	19.9	14 000	12 000	10 700	10 500	7 700	6 200	45	35	1 750	3 500	1000	5K
	23.6	16 000	14 000	12 500	11 200	8 000	6 500	45	35	1 750	3 500	800	5G
R3	32.2	12 000	11 000	9 500	7 200	4 400	3 600	25	20	1 750	3 500	440	4L
	41.3	14 300	12 600	10 000	8 600	5 600	4 800	22	20	1 750	3 500	440	4L
	47.4	17 300	14 600	11 000	9 600	5 600	4 800	20	20	1 750	3 500	440	4L
	56.4	18 000	17 000	16 000	14 200	8 400	6 600	20	20	1 750	3 500	400	4K
	67.3	21 000	18 100	16 200	16 000	10 700	8 700	22	20	1 750	3 500	400	4K
	75	18 000	17 500	16 500	15 200	9 400	7 600	20	20	1 750	3 500	330	4H
	91.7	17 000	14 400	13 000	13 000	10 400	8 500	18	20	1 750	3 500	260	4F
	109	17 000	14 400	13 000	13 000	10 400	8 500	16	20	1 750	3 500	260	4F
R4	128	21 300	20 600	19 000	15 600	9 600	7 800	15.5	14	1 750	3 500	260	4F
	168	21 300	20 600	19 000	15 600	9 600	7 800	15	14	1 750	3 500	160	4D
	219	21 300	20 600	19 000	15 600	9 600	7 800	12	14	1 750	3 500	160	4D
	260	18 000	17 500	16 500	15 200	9 400	7 600	10.5	14	1 750	3 500	100	4B
	310	21 000	18 100	16 200	16 000	10 700	8 700	9	14	1 750	3 500	100	4B
	346	18 000	17 500	16 500	15 200	9 400	7 600	8	14	1 750	3 500	100	4B
	433	18 000	17 500	16 500	15 200	9 400	7 600	7	14	1 750	3 500	50	4A
	529	17 000	14 400	13 000	13 000	10 400	8 500	4.5	14	1 750	3 500	50	4A
	627	17 000	14 400	13 000	13 000	10 400	8 500	4	14	1 750	3 500	50	4A
	714	7 000	5 900	5 500	5 500	4 700	3 850	1.5	12	1 750	3 500	50	4A

M_{2max}=1.2×Mn₂(n₂×h=10 000)

EP309L

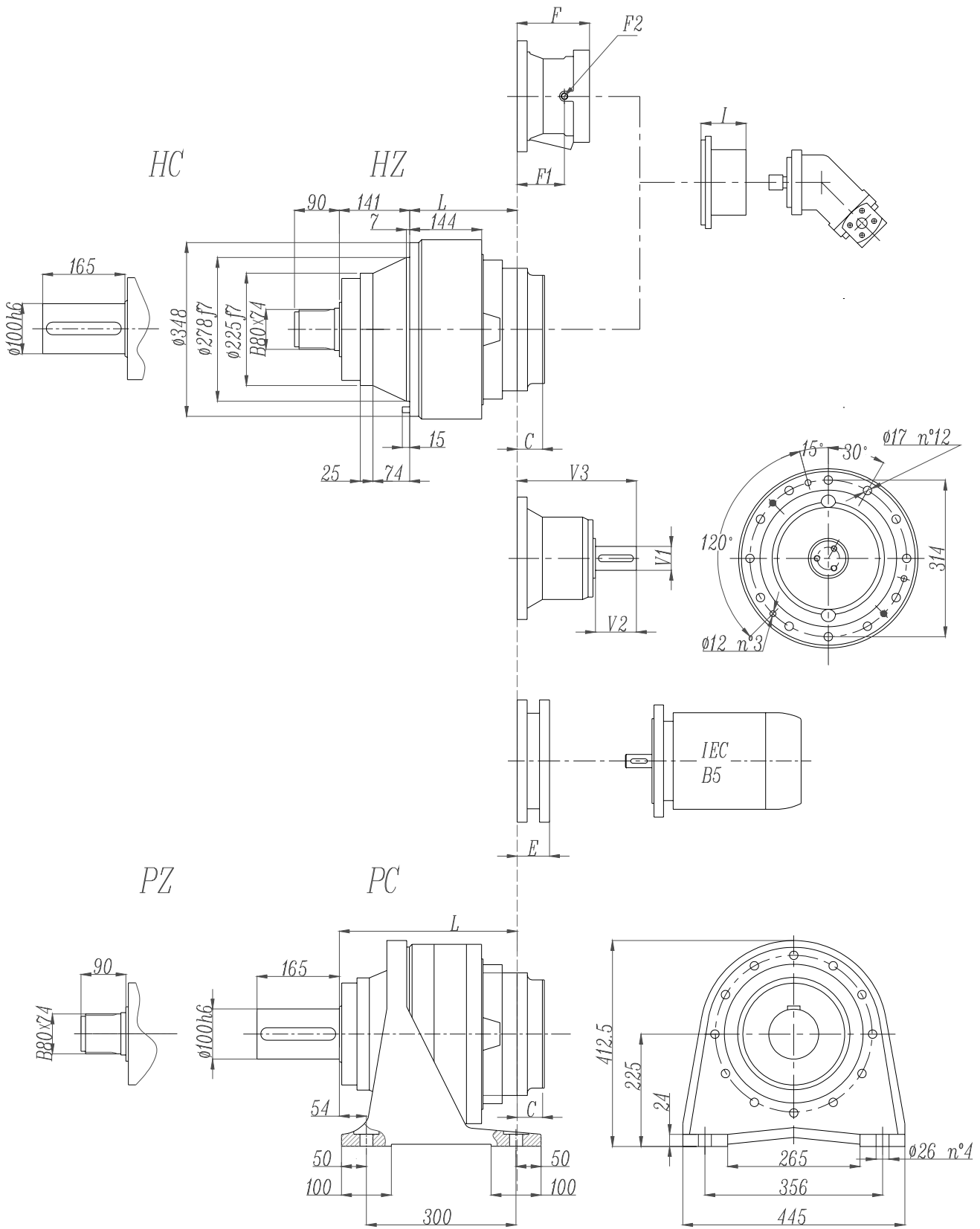

EP309L

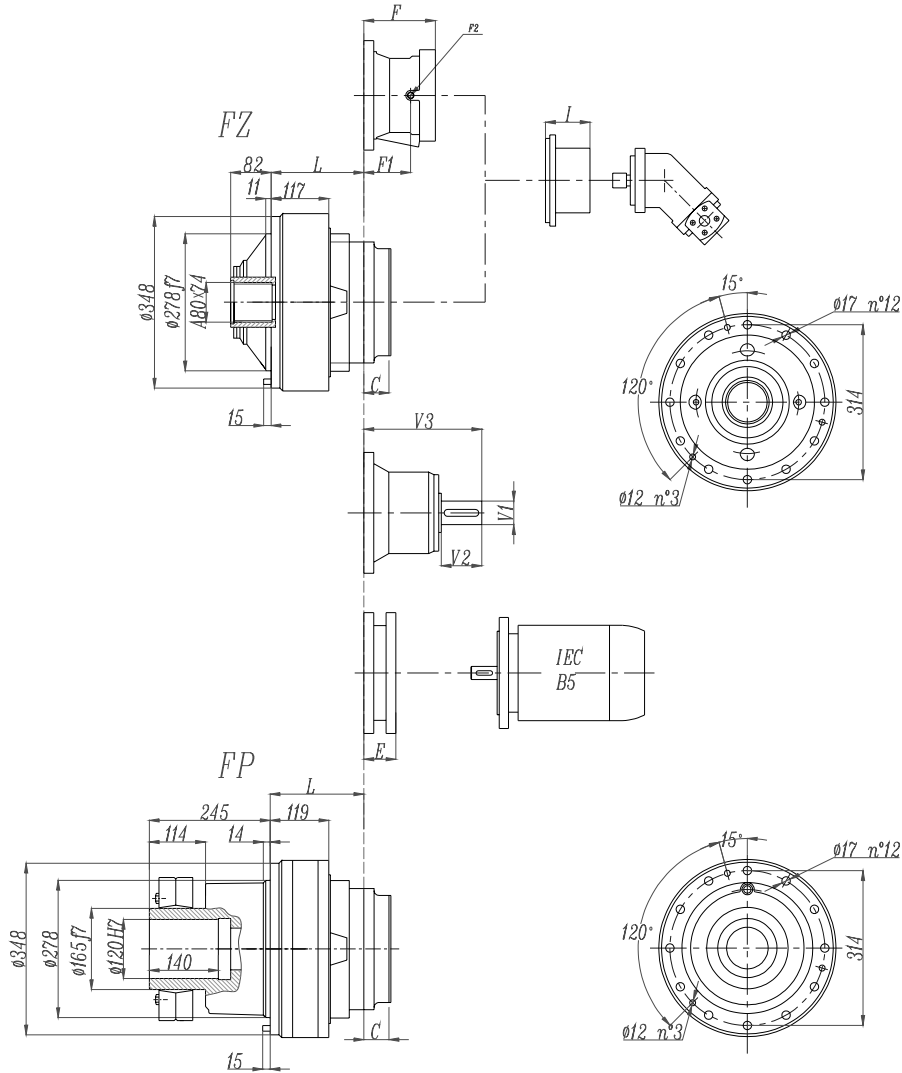

FP version
Max. transmissible
25000 N.m

	L				Ref. weight (without input) (Kg)				C	I	Brake				
	HZ HC	PC PZ	FZ	FP	HZ HC	PC PZ	FZ	FP			F	F1	F2	Type	Ref. Weight
309L1	126	267	99	101	115	130	95	100	51	According to hydraulic motor	201	153	1/4 G	6	38 Kg
309L2	219	360	192	194	127	142	107	112	37		145	95	1/4 G	5	22 Kg
309L3	284	425	257	259	134	149	114	119	37		105	65	1/4 G	4	15 Kg
309L4	337	478	310	312	138	153	118	123	37		105	65	1/4 G	4	15 Kg

	E (IEC motor input)												
	IEC 71	IEC 80	IEC 90	IEC 100	IEC 112	IEC 132	IEC 160	IEC 180	IEC 200	IEC 225	IEC 250		
309L1								195	186	216	216		
309L2						114	144	144	174				
309L3	65	84	84	94	94	114	144						
309L4	65	84	84	94	94	114	144						

EP309R

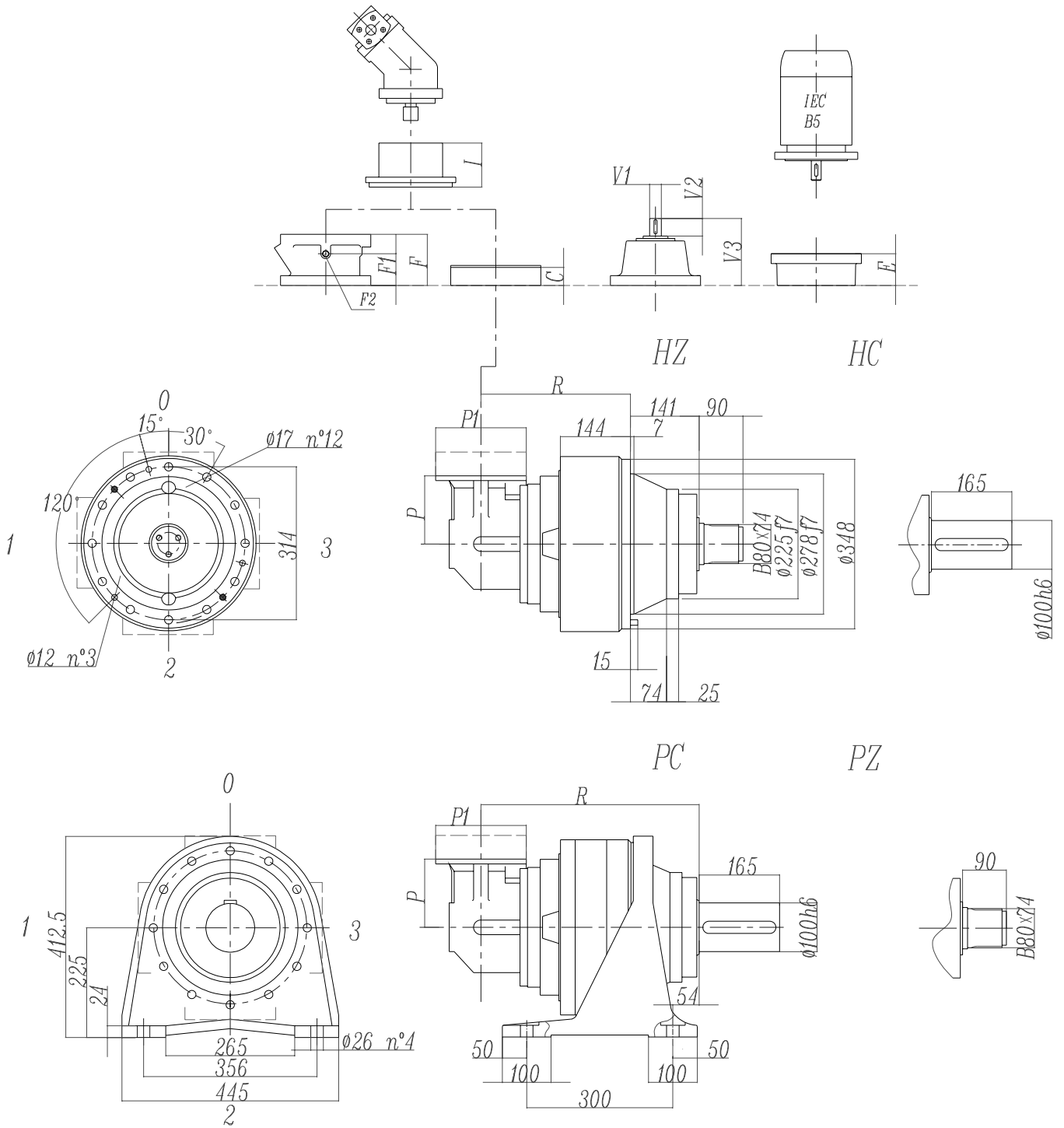

EP309R

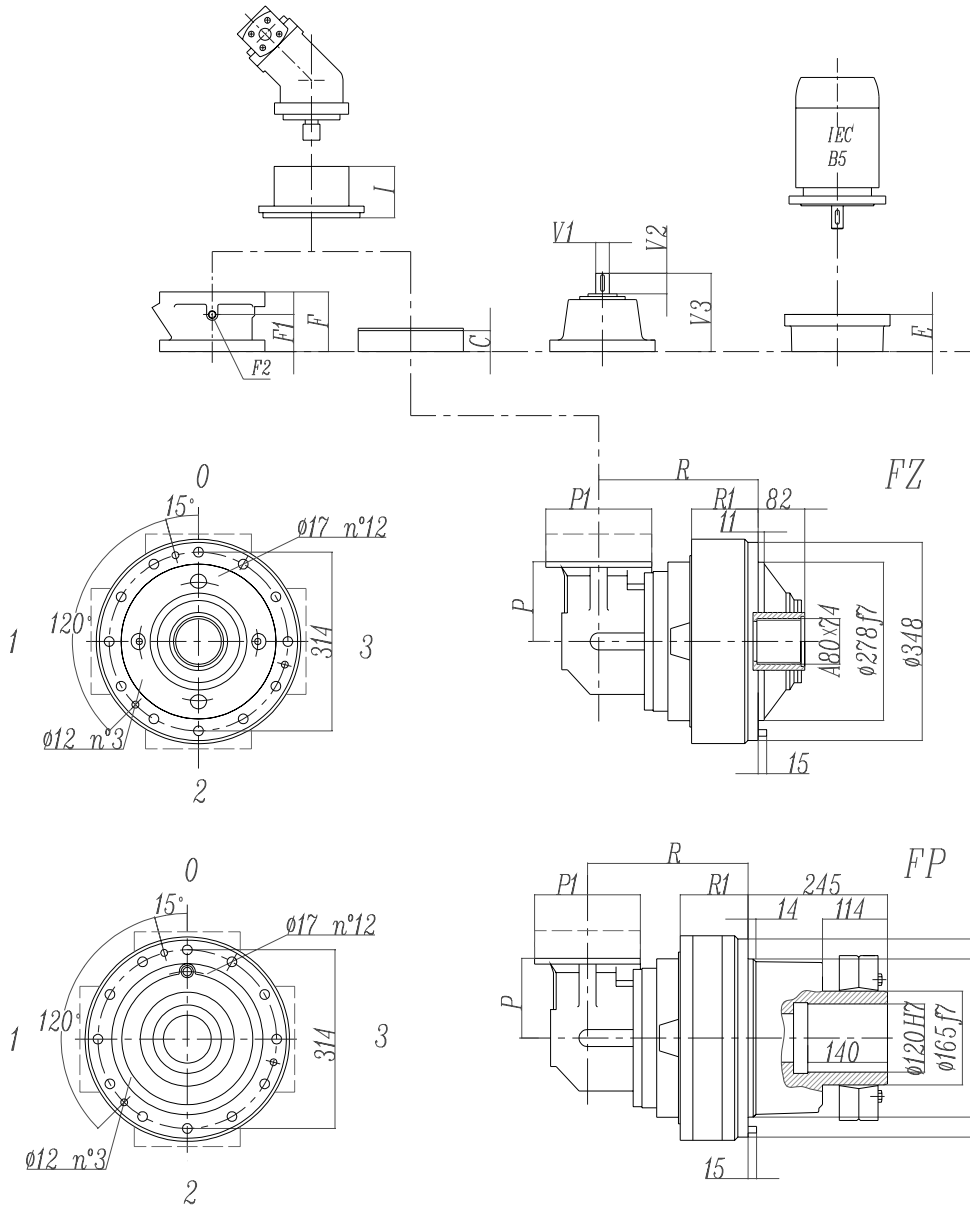

FP version
Max. transmissible
25000 N.m

	R				Ref. weight (without input) (Kg)				C	P	I	Brake				
	HZ HC	PC PZ	FZ	FP	HZ HC	PC PZ	FZ	FP				F	F1	F2	Type	Ref. Weight 15 Kg
309R2	245	386	218	220	165	180	145	150	37	225	According to hydraulic motor	145	95	1/4 G	4	22
309R3	311	452	284	286	147	162	127	132	37	140		105	65	1/4 G	4	15
309R4	376	517	349	351	148	163	128	133	37	122		105	65	1/4 G	4	15

	P1	R1				E (IEC motor input)									
		HZ	HC	FZ	FP	IEC 71	IEC 80	IEC 90	IEC 100	IEC 112	IEC 132	IEC 160	IEC 180	IEC 200	
309R2	245	168	168	141	143						114	144	144	174	
309R3	186	144	144	117	119	65	84	84	94	94	114	144			
309R4	186	144	144	117	119	65	84	84	94	94	114	144			

EP309L - EP309R

Drive intake flange

DIF

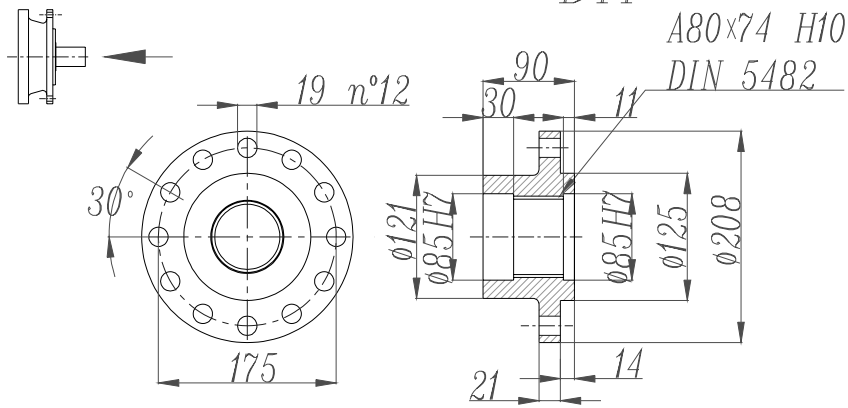

Sleeve couplings

SC

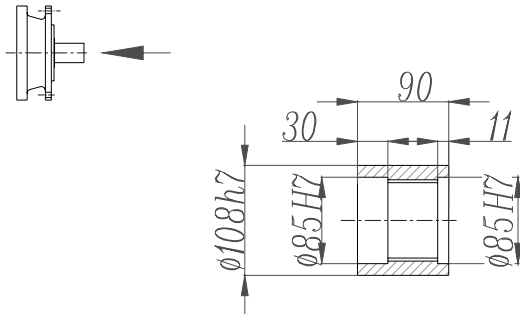

Splined bars

SB

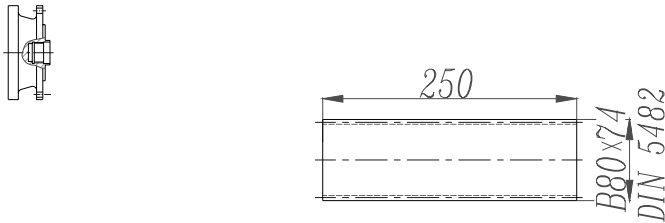

Shrink disc

SD

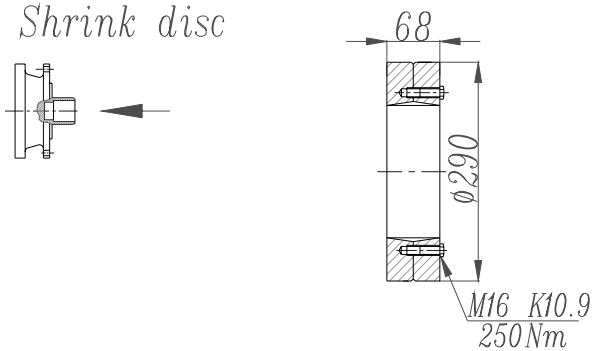

FP version

Max. transmissible

25000 N.m

EP309L - EP309R

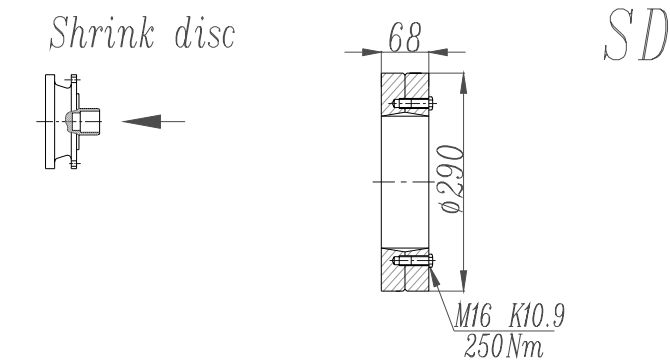
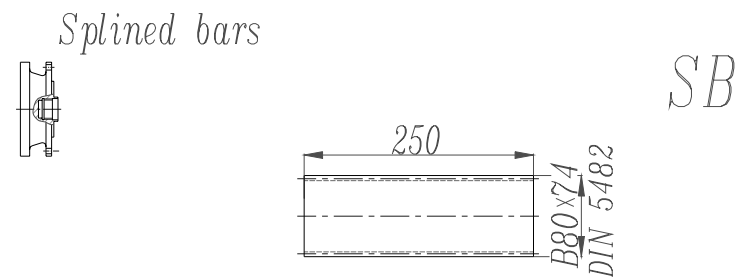
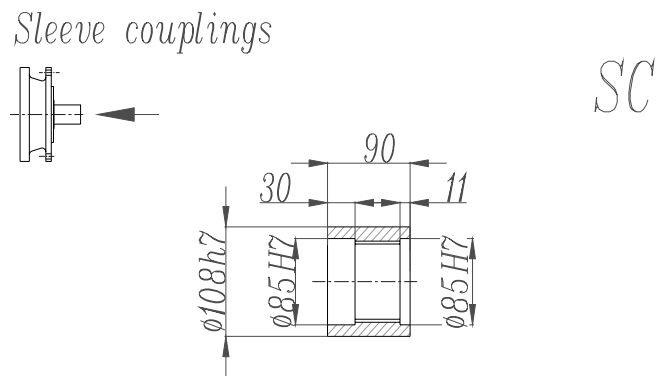
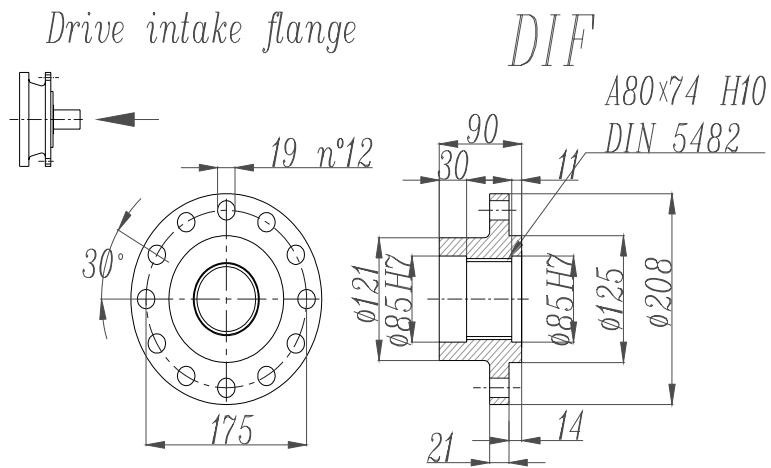

EP309L - EP309R

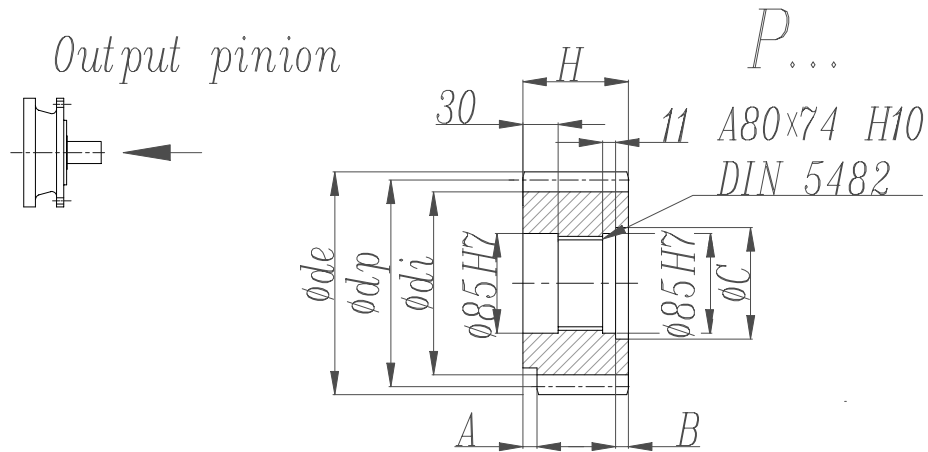

	m	z	x	dp	di	de	H	A	B	C
PFG	8	16	0.5000	128	117	149.5	90	0	0	0
PHC	10	12	0.4500	120	104	145	90	0	0	0
PHE	10	14	0.320	140	121	162.5	116	13	26	95
PHF	10	15	0.150	150	130	171.5	107	20	17	100
PHG	10	16	0.500	160	145	186	90	10	0	0
PHH1	10	17	0	170	145	190	90	0	0	0
PHH2	10	17	0.500	170	154	198	90	0	0	0
PLD	12	13	0.500	156	138	192	102	0	12	95
PLE	12	14	0.500	168	150	199.2	90	0	0	0
PLI	12	18	0.500	216	198	249.6	107	7	17	95
PLT	12	26	0	312	282	336	90	0	0	0

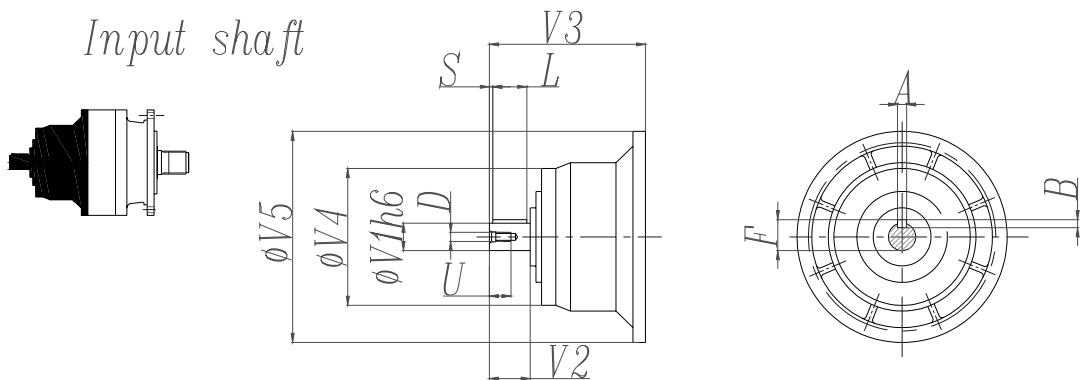

	CODE	V1	V2	V3	V4	V5	A	B	F	L	S	D	U
309L1	V07B	80	130	315	200	345	22	14	85	110	10	M16	36
	V07A	60	105	313	155	345	18	11	64	90	7.5	M16	36
309L2	V05B	48	82	239	155	245	14	9	51.5	70	6	M16	36
309L3	V01A	24	36	137.5	120	186	8	7	27	30	3	M8	19
	V01B	38	58	158	120	186	10	8	41	50	4	M12	28
309L4	V01A	24	36	137.5	120	186	8	7	27	30	3	M8	19
	V01B	38	58	158	120	186	10	8	41	50	4	M12	28
309R2	V05B	48	82	239	155	245	14	9	51.5	70	6	M16	36
309 R3-R4	V01A	24	36	137.5	120	186	8	7	27	30	3	M8	19
	V01B	38	58	158	120	186	10	8	41	50	4	M12	28

EP309L - EP309R

Permissible radial and axial loads on output shaft with Fh2 ($n_2 \cdot h=10\ 000$)

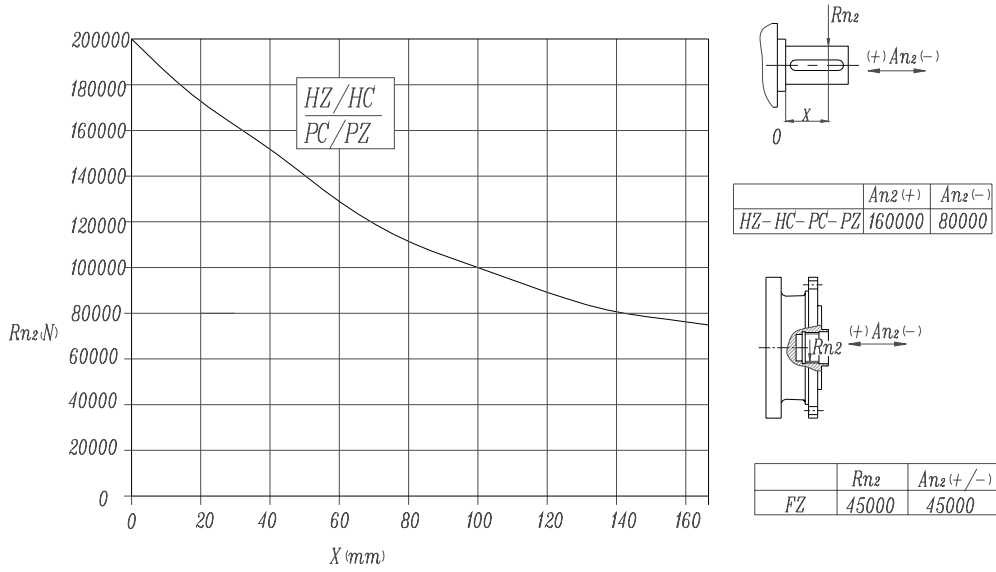

Load corrective factor fh2 on shafts	fh2= $n_2 \cdot h$		10 000	25 000	50 000	100 000	500 000	1 000 000
		fh2	MZ-MC-PC-PZ-FZ	1	0.74	0.58	0.46	0.27
		HZ-HC	1	0.76	0.61	0.50	0.31	0.25

Permissible radial loads on input shaft with Fh1 ($n_1 \cdot h=250\ 000$)

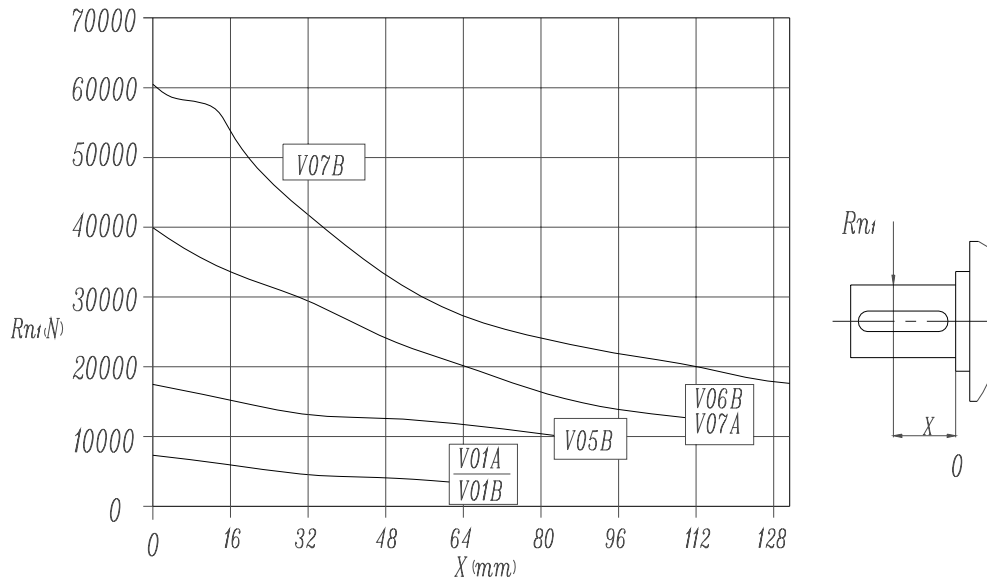

Load corrective factor fh1 on shafts	Fh1= $n_1 \cdot h$		250 000	500 000	1 000 000	2 00 000	5 000 000	10 000 000
		fh1		1	0.79	0.63	0.50	0.37

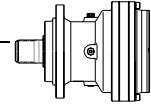

EP310L

M2'=25000N.m

	I 1:	Mn ₂ (N.m)						P ₁ (KW)	P _t (KW) (ta=20°C) (n ₁ =1500)	n ₁ (min ⁻¹)	n _{1max} (min ⁻¹)	M _b (N.m)	Brake type
		n ₂ .h 10000	n ₂ .h 25000	n ₂ .h 50000	n ₂ .h 100000	n ₂ .h 500000	n ₂ .h 1000000						
L1	4.2	30000	30000	26000	21000	13000	11000	150	35	1000	1500		
	5.0	29000	25000	22000	20000	13000	11000	150	35	1000	1500		
	6.8	26000	21000	18000	17000	12000	10000	150	35	1000	1500		
L2	15.5	30000	30000	26000	21000	13000	11000	100	22	1500	2500	2100	6G
	17.6	30000	30000	26000	21000	13000	11000	90	22	1500	2500	2100	6G
	21.0	29000	25000	22000	20000	13000	11000	80	22	1500	2500	1500	6E
	24.7	29000	25000	22000	20000	13000	11000	75	22	1500	2500	1500	6E
	28.9	29000	25000	22000	20000	13000	11000	70	22	1500	2500	1100	6C
	33.7	26000	21000	18000	17000	12000	10000	65	22	1500	2500	1100	6C
	39.4	26000	21000	18000	17000	12000	10000	55	22	1500	2500	850	6B
	48.3	26000	21000	18000	17000	12000	10000	50	22	1500	2500	850	6B
	L3	56.7	30000	30000	26000	21000	13000	11000	50	18	1 750	3 500	630
73.9		30000	30000	26000	21000	13000	11000	42	18	1 750	3 500	630	5E
88.0		30000	30000	26000	21000	13000	11000	37	18	1 750	3 500	500	5C
105		29000	25000	22000	20000	13000	11000	32	18	1 750	3 500	400	5B
124		29000	25000	22000	20000	13000	11000	28	18	1 750	3 500	400	5B
145		29000	25000	22000	20000	13000	11000	24	18	1 750	3 500	400	5B
161		29000	25000	22000	20000	13000	11000	22	18	1 750	3 500	400	5B
197		29000	25000	22000	20000	13000	11000	19	18	1 750	3 500	400	5B
220		26000	21000	18000	17000	12000	10000	14	18	1 750	3 500	400	5B
269		26000	21000	18000	17000	12000	10000	11.5	18	1 750	3 500	400	5B
330	26000	21000	18000	17000	12000	10000	9.5	18	1 750	3 500	400	5B	
L4	329	30000	30000	26000	21000	13000	11000	12	11	1 750	3 500	100	4B
	426	30000	30000	26000	21000	13000	11000	9.5	11	1 750	3 500	100	4B
	508	30000	30000	26000	21000	13000	11000	8.5	11	1 750	3 500	100	4B
	604	29000	25000	22000	20000	13000	11000	6.5	11	1 750	3 500	100	4B
	713	29000	25000	22000	20000	13000	11000	5.6	11	1 750	3 500	50	4A
	834	29000	25000	22000	20000	13000	11000	4.8	11	1 750	3 500	50	4A
	930	29000	25000	22000	20000	13000	11000	4.4	11	1 750	3 500	50	4A
	1160	29000	25000	22000	20000	13000	11000	3.8	11	1 750	3 500	50	4A
	1268	26000	21000	18000	17000	12000	10000	3	11	1 750	3 500	50	4A
	1420	29000	25000	22000	20000	13000	11000	3.3	11	1 750	3 500	50	4A
1582	26000	21000	18000	17000	12000	10000	2.5	11	1 750	3 500	50	4A	
1937	26000	21000	18000	17000	12000	10000	2.2	11	1 750	3 500	50	4A	
2373	26000	21000	18000	17000	12000	10000	1.8	11	1 750	3 500	50	4A	

M_{2max}=1.2×Mn₂(n₂×h=10 000)

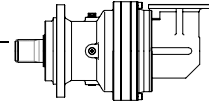

EP310R

M2'=25000N.m

	I	Mn ₂ (N.m)						P ₁	P _t (KW) (ta=20°C) (n ₁ =1500)	n ₁	n _{1max}	M _b	Brake type	
		n ₂ .h 10000	n ₂ .h 25000	n ₂ .h 50000	n ₂ .h 100000	n ₂ .h 500000	n ₂ .h 1000000							(KW)
R2	12.3	21000	20000	19000	16000	10000	8000	130	55	1 500	2 500	2600	6K	
	14.6	25000	21500	20000	17500	11000	8500	130	55	1 500	2 500	2100	6G	
	20.0	26000	21000	18000	17000	12000	10000	130	55	1 500	2 500	1500	6E	
R3	39.6	21000	20000	19000	16000	10000	8000	45	20	1 750	3 500	440	4L	
	45.1	26000	21000	18000	17000	12000	10000	45	20	1 750	3 500	440	4L	
	53.7	29000	25000	22000	20000	13000	11000	41	20	1 750	3 500	440	4L	
	63.3	29000	25000	22000	20000	13000	11000	37	20	1 750	3 500	440	4L	
	74.1	29000	25000	22000	20000	13000	11000	33	20	1 750	3 500	440	4L	
	86.3	26000	21000	18000	17000	12000	10000	27	20	1 750	3 500	400	4K	
	101	26000	21000	18000	17000	12000	10000	24	20	1 750	3 500	400	4K	
	124	26000	21000	18000	17000	12000	10000	20	20	1 750	3 500	330	4H	
	R4	145	30000	30000	26000	21000	13000	11000	21	14	1 750	3 500	330	4H
		189	30000	30000	26000	21000	13000	11000	17	14	1 750	3 500	330	4H
226		30000	30000	26000	21000	13000	11000	15	14	1 750	3 500	260	4F	
268		29000	25000	22000	20000	13000	11000	13	14	1 750	3 500	160	4D	
317		29000	25000	22000	20000	13000	11000	11.5	14	1 750	3 500	160	4D	
371		29000	25000	22000	20000	13000	11000	10.2	14	1 750	3 500	100	4B	
413		29000	25000	22000	20000	13000	11000	9.3	14	1 750	3 500	100	4B	
505		29000	25000	22000	20000	13000	11000	7.7	14	1 750	3 500	100	4B	
563		26000	21000	18000	17000	12000	10000	6	14	1 750	3 500	100	4B	
689		26000	21000	18000	17000	12000	10000	5	14	1 750	3 500	50	4A	
845	26000	21000	18000	17000	12000	10000	4.3	14	1 750	3 500	50	4A		

M_{2max}=1.2×Mn₂(n₂×h=10 000)

EP310L

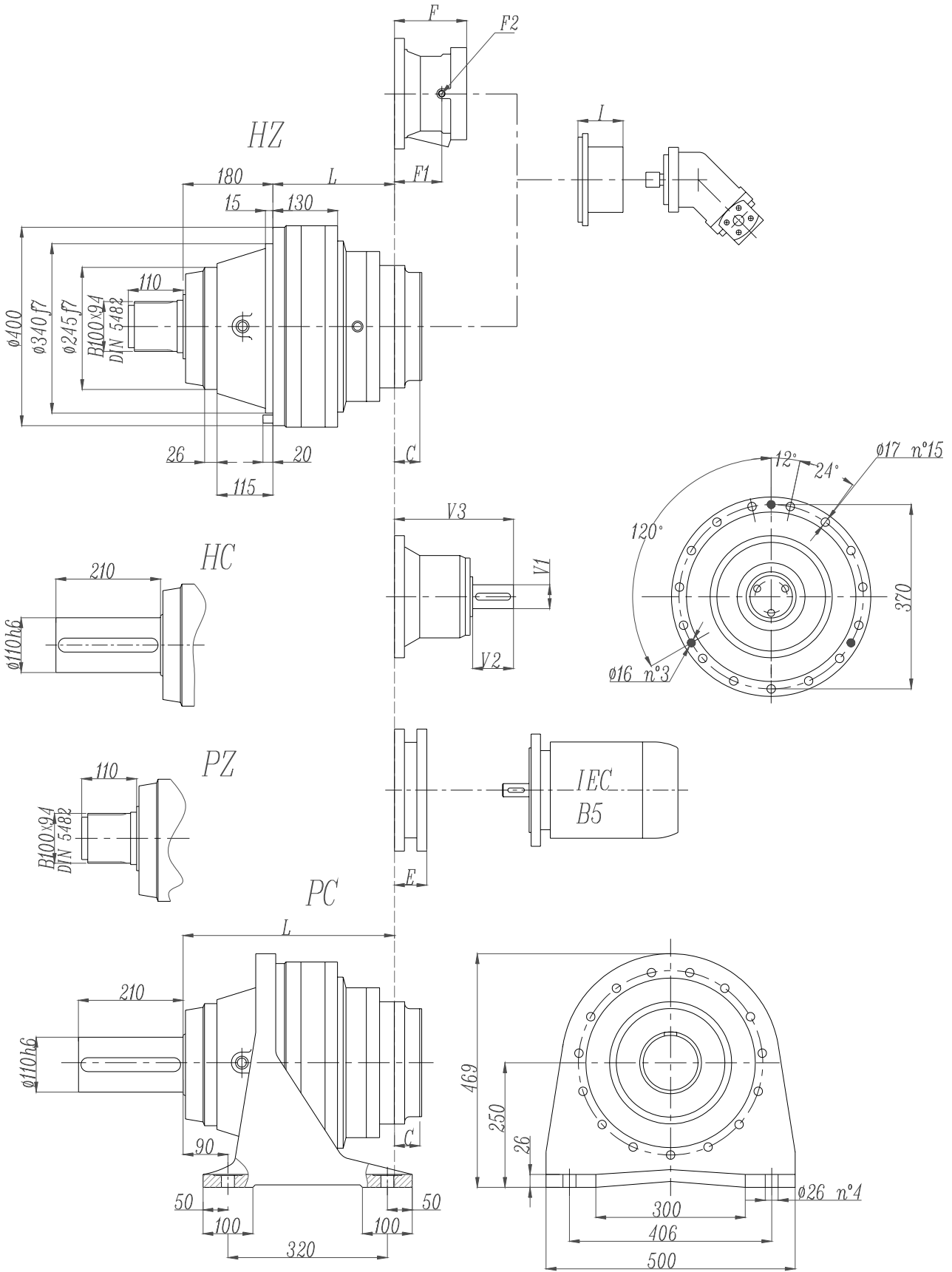

EP310L

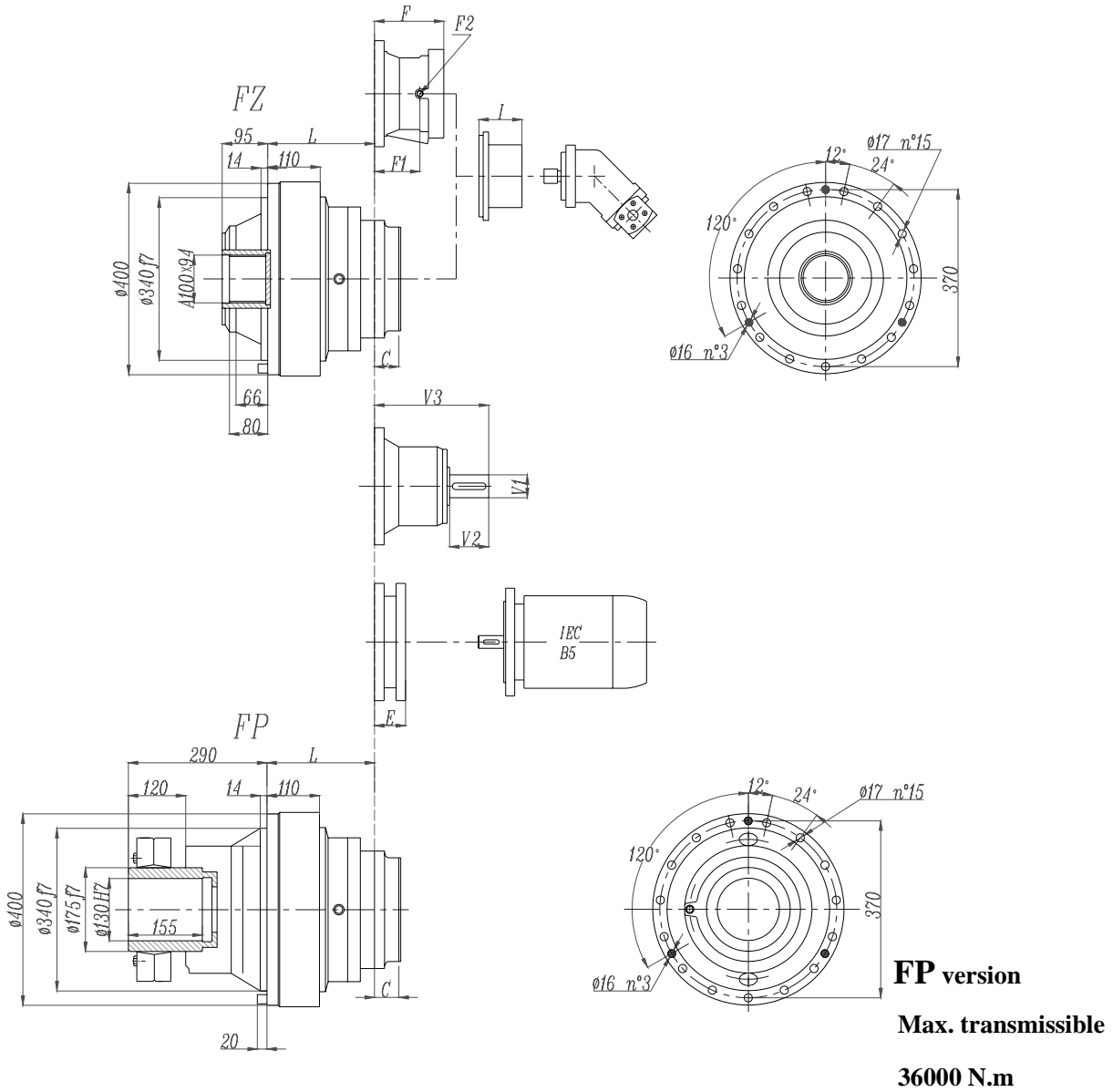

	L				Ref. weight (without input) (Kg)				C	I	Brake				
	HZ HC	PC PZ	FZ	FP	HZ HC	PC PZ	FZ	FP			F	F1	F2	Type	Ref. Weight
310L1	108	288	88	88	135	130	110	115	88	According to hydraulic motor					
310L2	244	424	224	224	165	142	140	145	45		195	147	1/4 G	6	38 Kg
310L3	313	493	293	293	178	149	153	158	37		145	95	1/4 G	5	22 Kg
310L4	366	546	346	346	182	153	157	162	37		105	65	1/4 G	4	15 Kg

	E (IEC motor input)													
	IEC 71	IEC 80	IEC 90	IEC 100	IEC 112	IEC 132	IEC 160	IEC 180	IEC 200	IEC 225	IEC 250			
310L1									271	301	281			
310L2								152	182	212	193			
310L3						114	144	144	174					
310L4	65	84	84	94	94	114	144							

EP310R

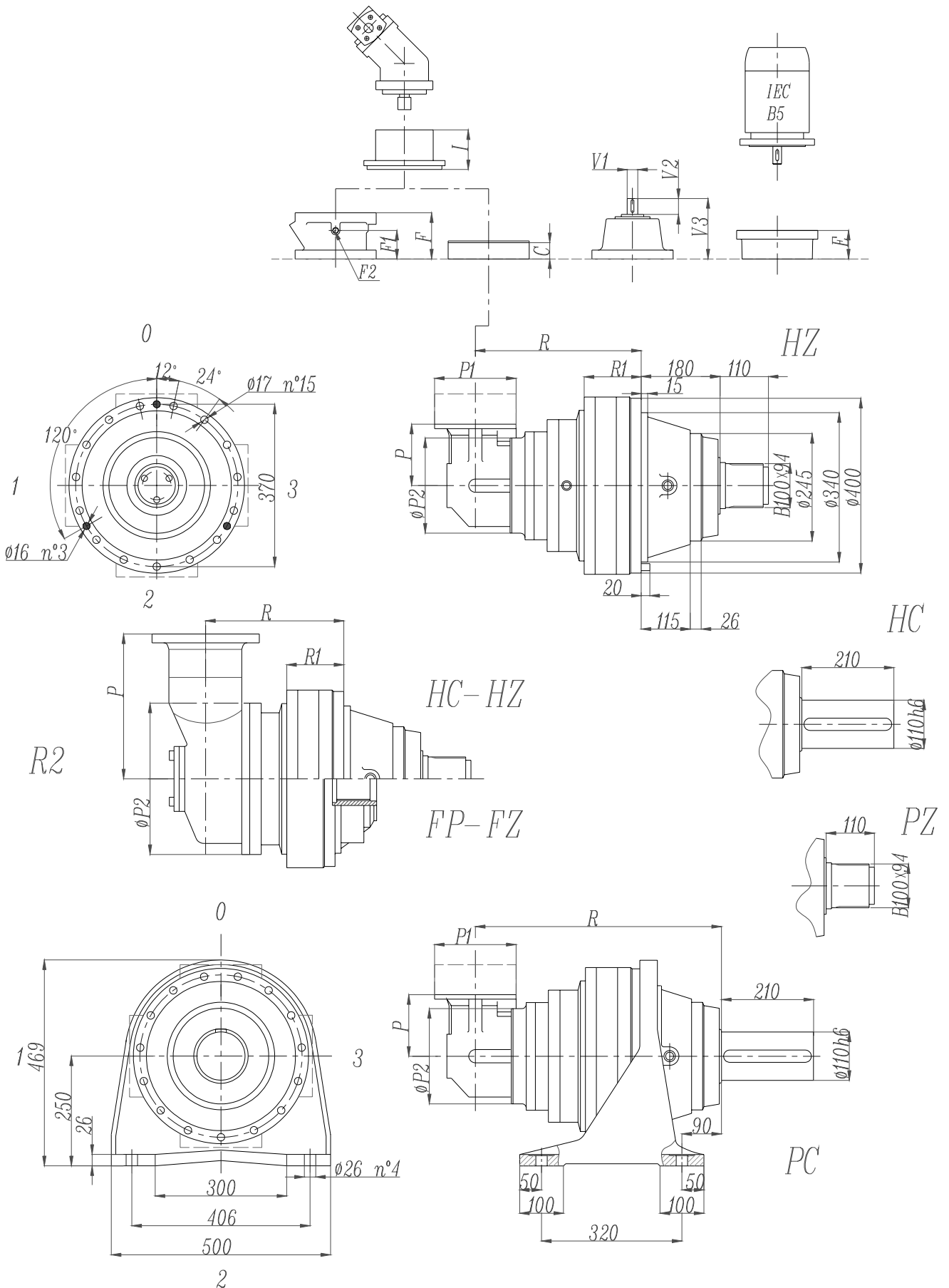

EP310R

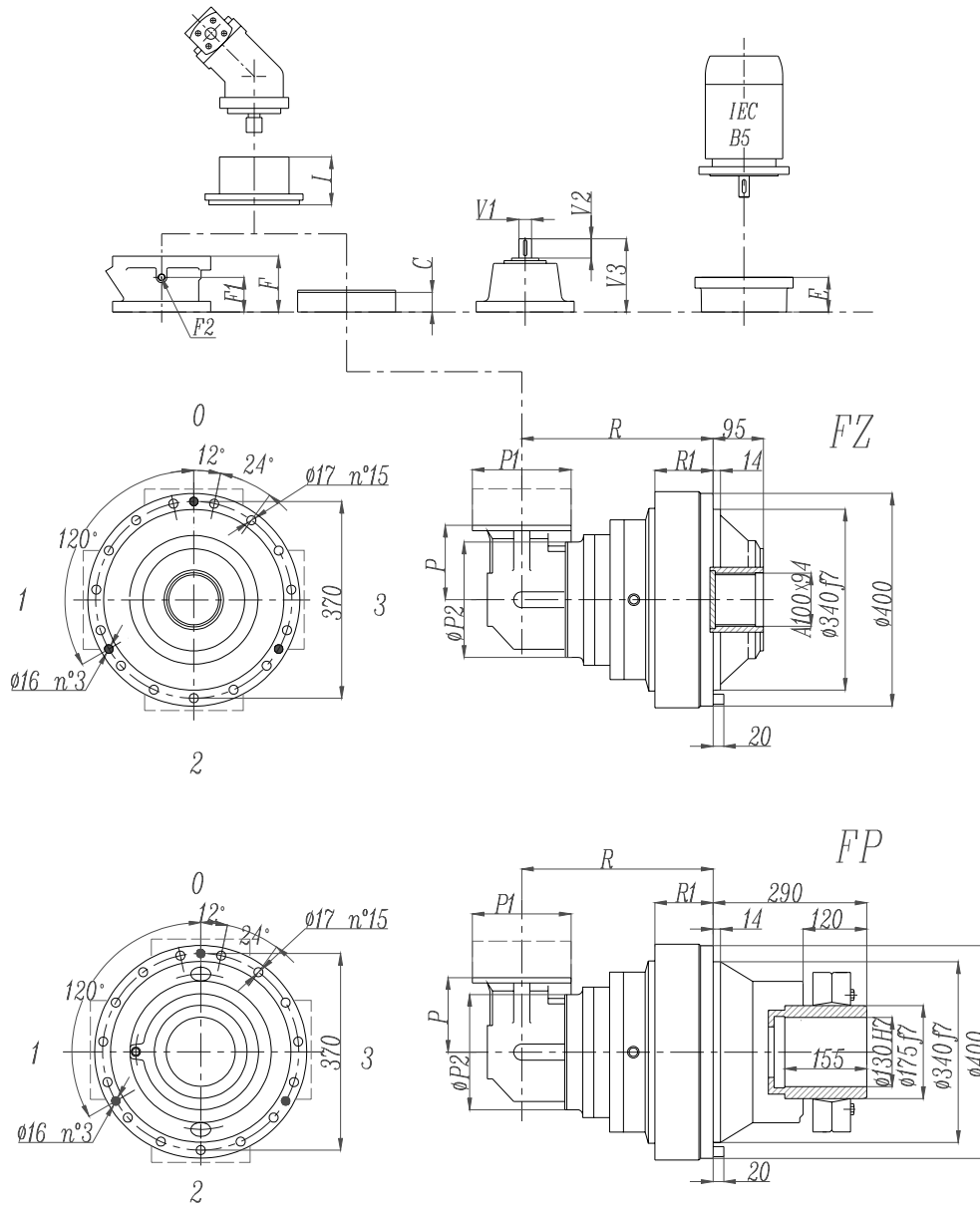

FP version
Max. transmissible
36000 N.m

	R				Ref. weight (without input) (Kg)				C	P	I	Brake				
	HZ HC	PC PZ	FZ	FP	HZ HC	PC PZ	FZ	FP				F	F1	F2	Type	Ref. Weight 15 Kg
310R2	315	495	218	295	260	280	240	250	45	345	According to hydraulic motor	195	147	1/4 G	6	38
310R3	381	561	284	361	189	209	164	169	37	140		145	95	1/4 G	4	22
310R4	405	585	349	385	194	214	169	174	37	140		105	65	1/4 G	4	15

	P1	R1				E (IEC motor input)										
		HZ	HC	FZ	FP	IEC 71	IEC 80	IEC 90	IEC 100	IEC 112	IEC 132	IEC 160	IEC 180	IEC 200	IEC 225	
310R2	292	130	130	110	110								152	182	212	
310R3	186	130	130	110	110						114	144	144	174	174	
310R4	186	130	130	110	110	65	84	84	94	94	114	144				

EP310L - EP310R

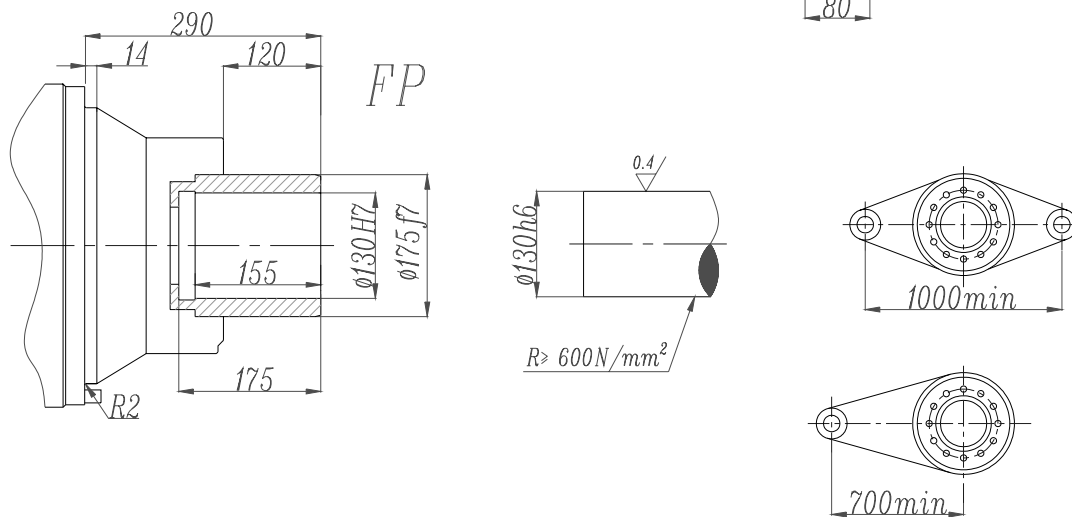
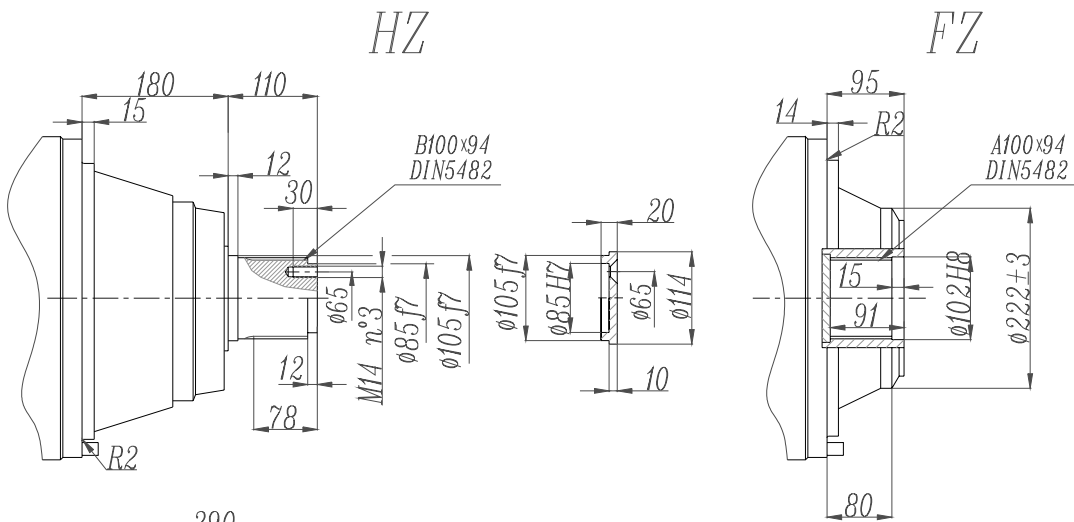
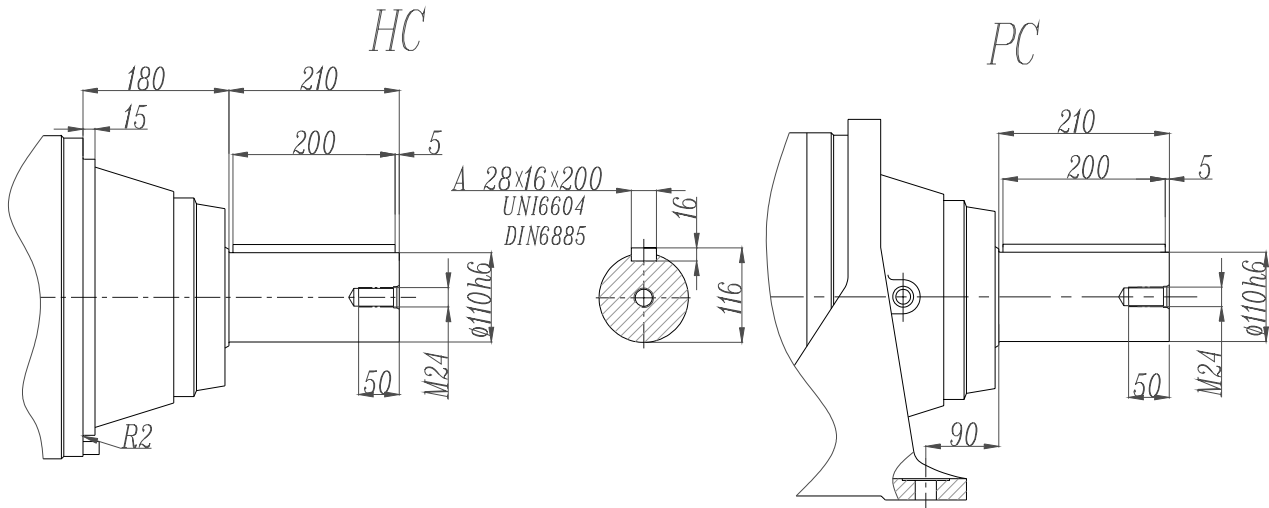

FP version

Max. transmissible

36000 N.m

EP310L - EP310R

Drive intake flange

DIF

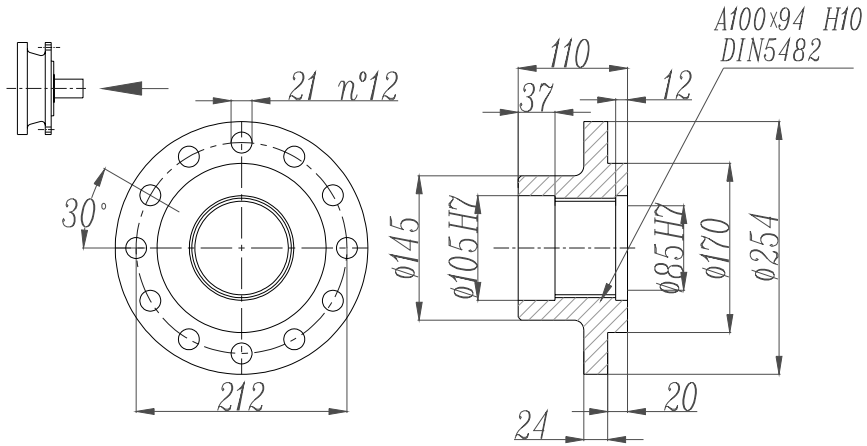

Sleeve couplings

SC

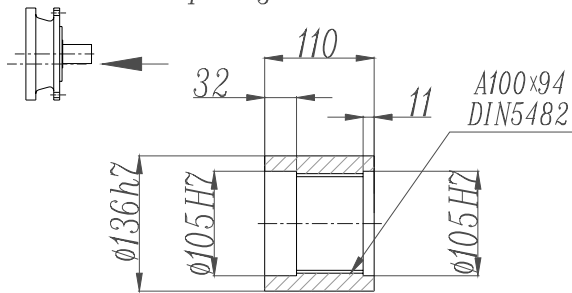

Splined bars

SB

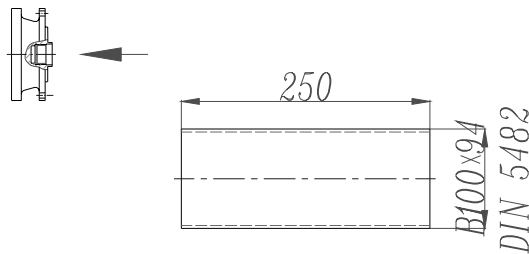

Shrink disc

SD

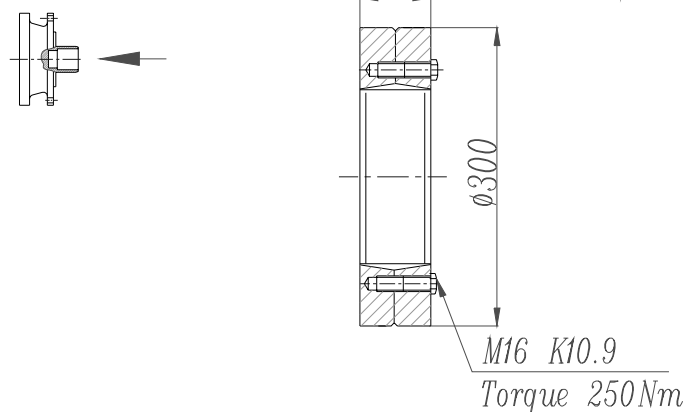

EP310L - EP310R

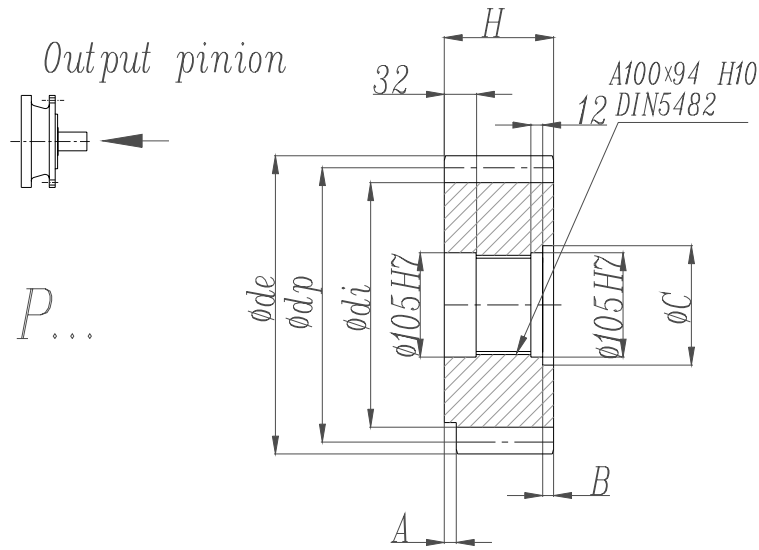

	m	z	x	dp	di	de	H	A	B	C
PLQ	12	23	0	276	246	300	110	0	0	0
PPD	16	13	0.5000	208	184	252.5	145	0	35	116
PPF	16	15	0.450	240	215	280	125	0	15	120

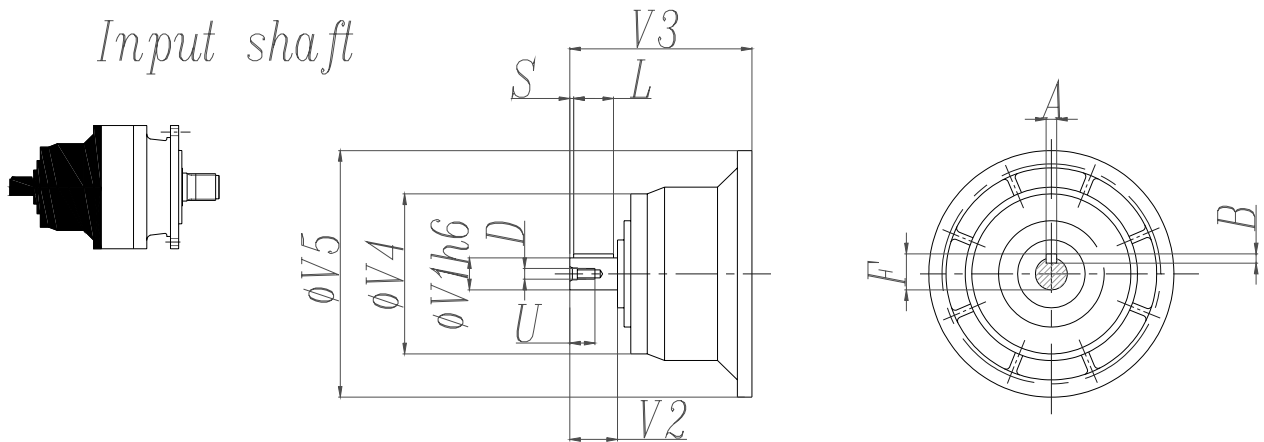

	CODE	V1	V2	V3	V4	V5	A	B	F	L	S	D	U
310L1	V10B	80	130	377	200	400	22	14	85	110	10	M16	36
310L2	V06B	60	105	307	155	292	18	11	64	90	7.5	M16	36
310L3	V05B	48	82	239	155	245	14	9	51.5	70	6	M16	36
310L4	V01A	24	36	137.5	120	186	8	7	27	30	3	M8	19
	V01B	38	58	158	120	186	10	8	41	50	4	M12	28
310R2	V06B	60	105	307	155	292	18	11	64	90	7.5	M16	36
310 R3-R4	V01A	24	36	137.5	120	186	8	7	27	30	3	M8	19
	V01B	38	58	158	120	186	10	8	41	50	4	M12	28

EP310L - EP310R

Permissible radial and axial loads on output shaft with Fh2 ($n_2 \cdot h=10\ 000$)

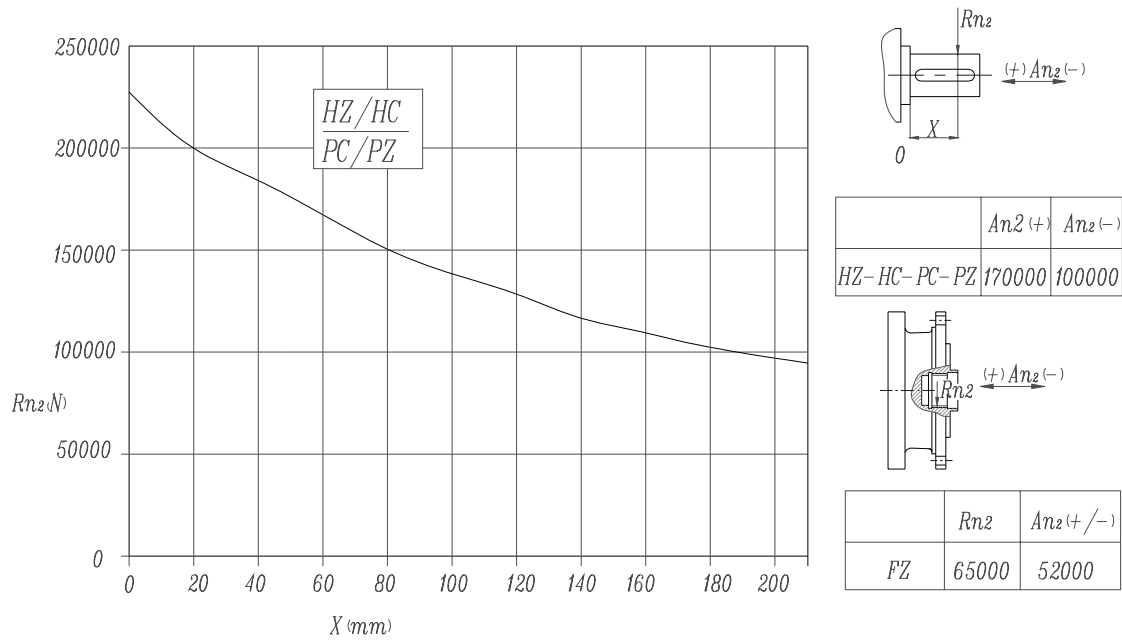

Load corrective factor fh2 on shafts	fh2= $n_2 \cdot h$		10 000	25 000	50 000	100 000	500 000	1 000 000
	fh2	MZ-MC-PC-PZ-FZ	1	0.74	0.58	0.46	0.27	0.21
		HZ-HC	1	0.76	0.61	0.50	0.31	0.25

Permissible radial loads on input shaft with Fh1 ($n_1 \cdot h=250\ 000$)

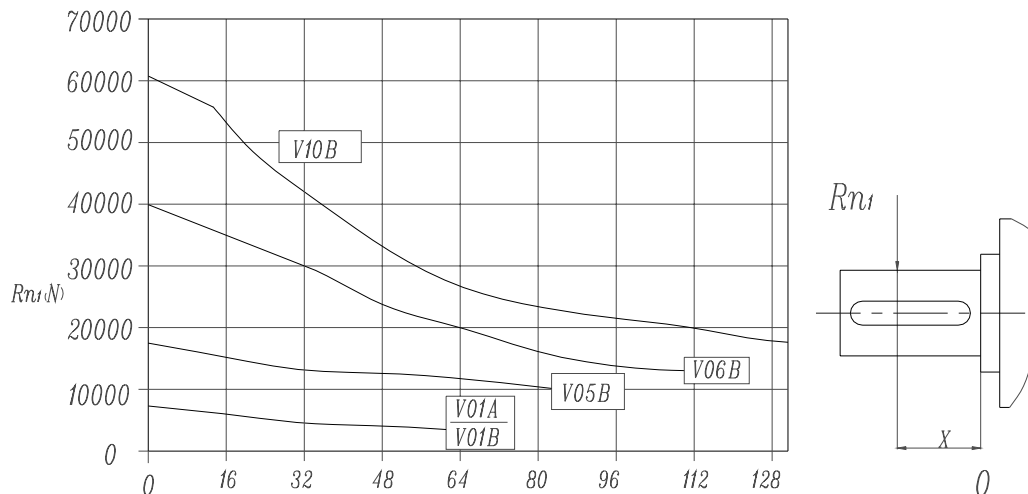

Load corrective factor fh1 on shafts	Fh1= $n_1 \cdot h$		250 000	500 000	1 000 000	2 00 000	5 000 000	10 000 000
	fh1		1	0.79	0.63	0.50	0.37	0.29

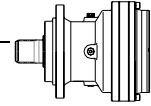

EP311L

M2'=35000N.m

	I 1:	Mn ₂ (N.m)						P ₁ (KW)	P _t (KW) (ta=20°C) (n ₁ =1500)	n ₁ (min ⁻¹)	n _{1max} (min ⁻¹)	M _b (N.m)	Brake type
		n ₂ .h 10000	n ₂ .h 25000	n ₂ .h 50000	n ₂ .h 100000	n ₂ .h 500000	n ₂ .h 1000000						
L1	4.1	45000	45000	37400	32000	19700	16000	180	35	750	1000		
	5.3	43000	36500	32300	32000	19700	16000	180	35	750	1000		
	6.2	34000	29500	27000	27000	18600	15100	180	35	750	1000		
L2	14.0	45000	45000	37400	32000	19700	16000	100	25	1500	2500	3200	6L
	18.0	45000	45000	37400	32000	19700	16000	100	25	1500	2500	3200	6L
	23.1	43000	36500	32300	32000	19700	16000	100	25	1500	2500	2600	6K
	27.6	43000	36500	32300	32000	19700	16000	100	25	1500	2500	2100	6G
	32.7	43000	36500	32300	32000	19700	16000	90	25	1500	2500	2100	6G
	38.8	34000	29500	27000	27000	18600	15100	80	25	1500	2500	1500	6E
	51.4	45000	45000	37400	32000	19700	16000	60	18	1 750	3 500	1000	5K
	66.0	45000	45000	37400	32000	19700	16000	50	18	1 750	3 500	1000	5K
L3	75.6	45000	45000	37400	32000	19700	16000	46	18	1 750	3 500	800	5G
	84.7	43000	36500	32300	32000	19700	16000	42	18	1 750	3 500	630	5E
	97.0	43000	36500	32300	32000	19700	16000	38	18	1 750	3 500	630	5E
	116	43000	36500	32300	32000	19700	16000	35	18	1 750	3 500	500	5C
	138	43000	36500	32300	32000	19700	16000	30	18	1 750	3 500	500	5C
	154	43000	36500	32300	32000	19700	16000	28	18	1 750	3 500	400	5B
	188	43000	36500	32300	32000	19700	16000	25	18	1 750	3 500	400	5B
	223	43000	36500	32300	32000	19700	16000	22	18	1 750	3 500	400	5B
L4	265	34000	29500	27000	27000	18600	15100	16	18	1 750	3 500	400	5B
	256	45000	45000	37400	32000	19700	16000	23	11	1 750	3 500	260	4F
	287	43000	36500	32300	32000	19700	16000	21	11	1 750	3 500	260	4F
	336	45000	45000	37400	32000	19700	16000	18	11	1 750	3 500	260	4F
	436	45000	45000	37400	32000	19700	16000	14	11	1 750	3 500	160	4D
	560	43000	36500	32300	32000	19700	16000	11.2	11	1 750	3 500	160	4D
	666	43000	36500	32300	32000	19700	16000	9.5	11	1 750	3 500	100	4B
	795	43000	36500	32300	32000	19700	16000	8	11	1 750	3 500	100	4B
	886	43000	36500	32300	32000	19700	16000	7.3	11	1 750	3 500	100	4B
	1106	43000	36500	32300	32000	19700	16000	6	11	1 750	3 500	100	4B
1353	43000	36500	32300	32000	19700	16000	5	11	1 750	3 500	50	4A	
1606	43000	36500	32300	32000	19700	16000	4.3	11	1 750	3 500	50	4A	
1906	34000	29500	27000	27000	18600	15100	3.1	11	1 750	3 500	50	4A	

M_{2max}=1.2×Mn₂(n₂×h=10 000)

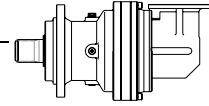

EP311R

M2'=35000N.m

	I	Mn ₂ (N.m)						P ₁ (KW)	P _t (KW) (ta=20°C) (n ₁ =1500)	n ₁ (min ⁻¹)	n _{1max} (min ⁻¹)	M _b (N.m)	Brake type
		n ₂ .h 10000	n ₂ .h 25000	n ₂ .h 50000	n ₂ .h 100000	n ₂ .h 500000	n ₂ .h 1000000						
R2	12.0	28000	27000	25000	24000	16000	12500	150	75	1 500	2 500	3200	6L
	15.4	35000	33000	31000	30000	18000	15000	150	75	1 500	2 500	3200	6L
	18.2	34000	30000	27000	26000	18000	15000	150	75	1 500	2 500	2600	6K
R3	53.1	34000	29500	27000	27000	18600	15100	60	40	1 750	3 500	800	5G
	68.1	45000	45000	37400	32000	19700	16000	50	40	1 750	3 500	800	5G
	87.5	43000	36500	32300	32000	19700	16000	45	40	1 750	3 500	630	5E
	104	43000	36500	32300	32000	19700	16000	40	40	1 750	3 500	630	5E
	124	43000	36500	32300	32000	19700	16000	35	40	1 750	3 500	500	5C
	147	34000	29500	27000	27000	18600	15100	30	40	1 750	3 500	400	5B
	R4	155	45000	45000	37400	32000	19700	16000	32	22	1 750	3 500	400
174		43000	36500	32300	32000	19700	16000	29	22	1 750	3 500	330	4H
199		43000	36500	32300	32000	19700	16000	26	22	1 750	3 500	330	4H
237		43000	36500	32300	32000	19700	16000	23	22	1 750	3 500	260	4F
283		43000	36500	32300	32000	19700	16000	20.5	22	1 750	3 500	260	4F
315		43000	36500	32300	32000	19700	16000	18.6	22	1 750	3 500	160	4D
385		43000	36500	32300	32000	19700	16000	15.5	22	1 750	3 500	160	4D
457		43000	36500	32300	32000	19700	16000	13.3	22	1 750	3 500	160	4D
543		34000	29500	27000	27000	18600	15100	9.5	22	1 750	3 500	100	4B

M_{2max}=1.2×Mn₂(n₂×h=10 000)

EP311 L

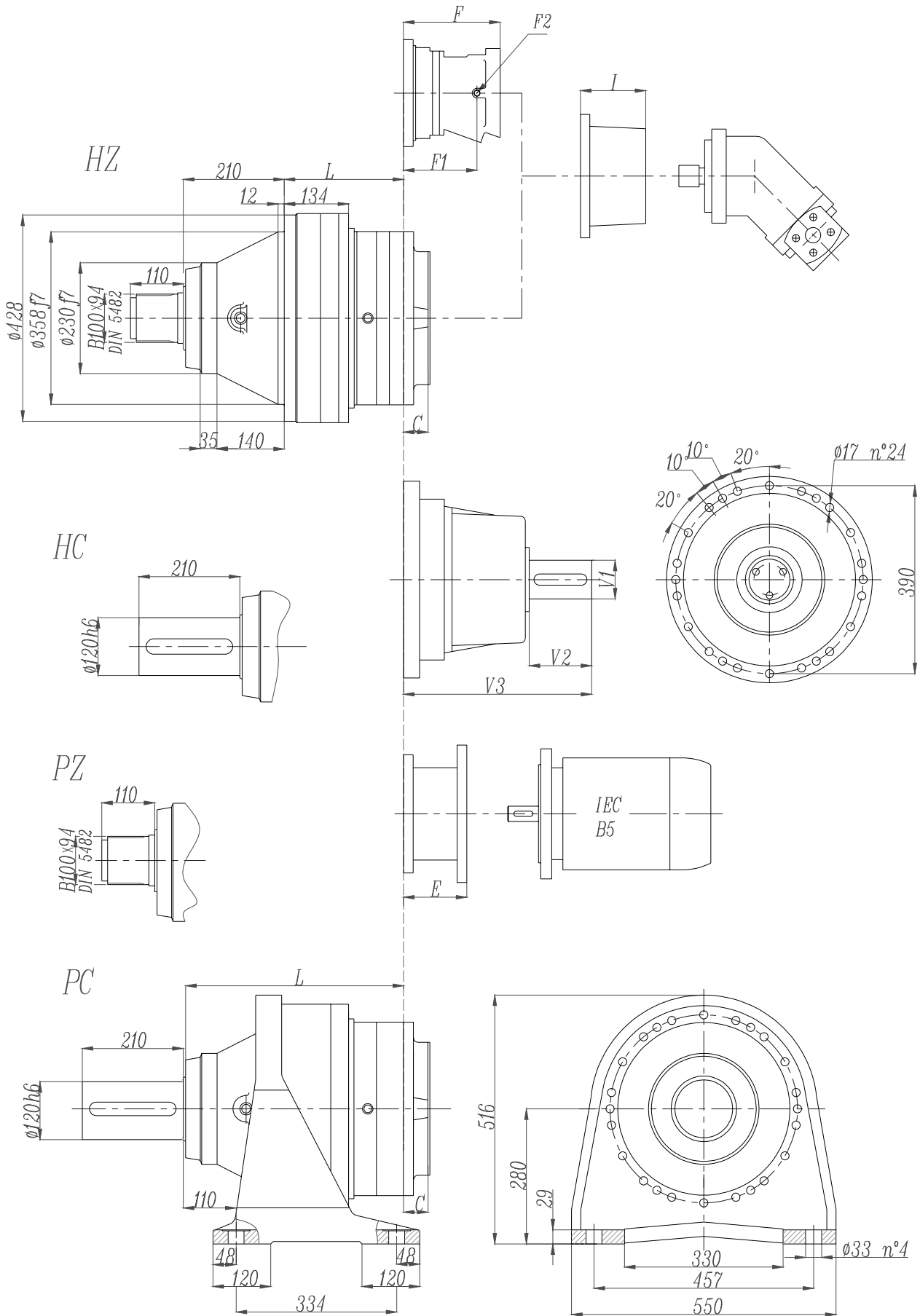

EP311 L

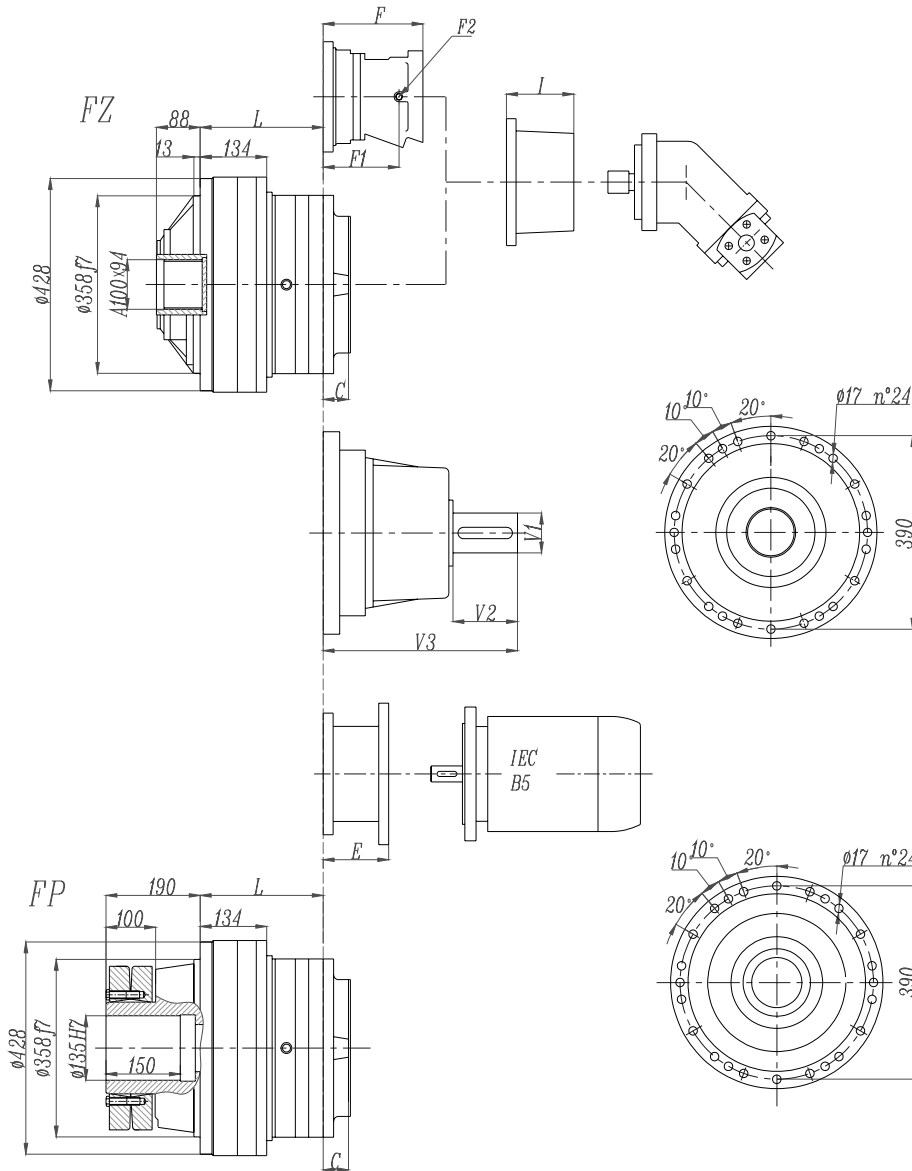

FP version
Max. transmissible
54000 N.m

	L				Ref. weight (without input) (Kg)				C	I	Brake				
	HZ HC	PC PZ	FZ	FP	HZ HC	PC PZ	FZ	FP			F	F1	F2	Type	Ref. Weight
311 L1	115	325	115	115	180	250	160	170	81	According to hydraulic motor					
311 L2	248	458	248	248	225	295	205	215	51		201	153	1/4 G	6	38 Kg
311 L3	341	551	341	341	237	307	217	227	37		145	95	1/4 G	5	22 Kg
311 L4	406	616	406	406	244	314	224	234	37		105	65	1/4 G	4	15 Kg

	E (IEC motor input)													
	IEC 71	IEC 80	IEC 90	IEC 100	IEC 112	IEC 132	IEC 160	IEC 180	IEC 200	IEC 225	IEC 250			
311 L1														
311 L2								195	186	216	215			
311 L3						114	144	144	174					
311 L4	65	84	84	94	94	114	144							

EP311 R

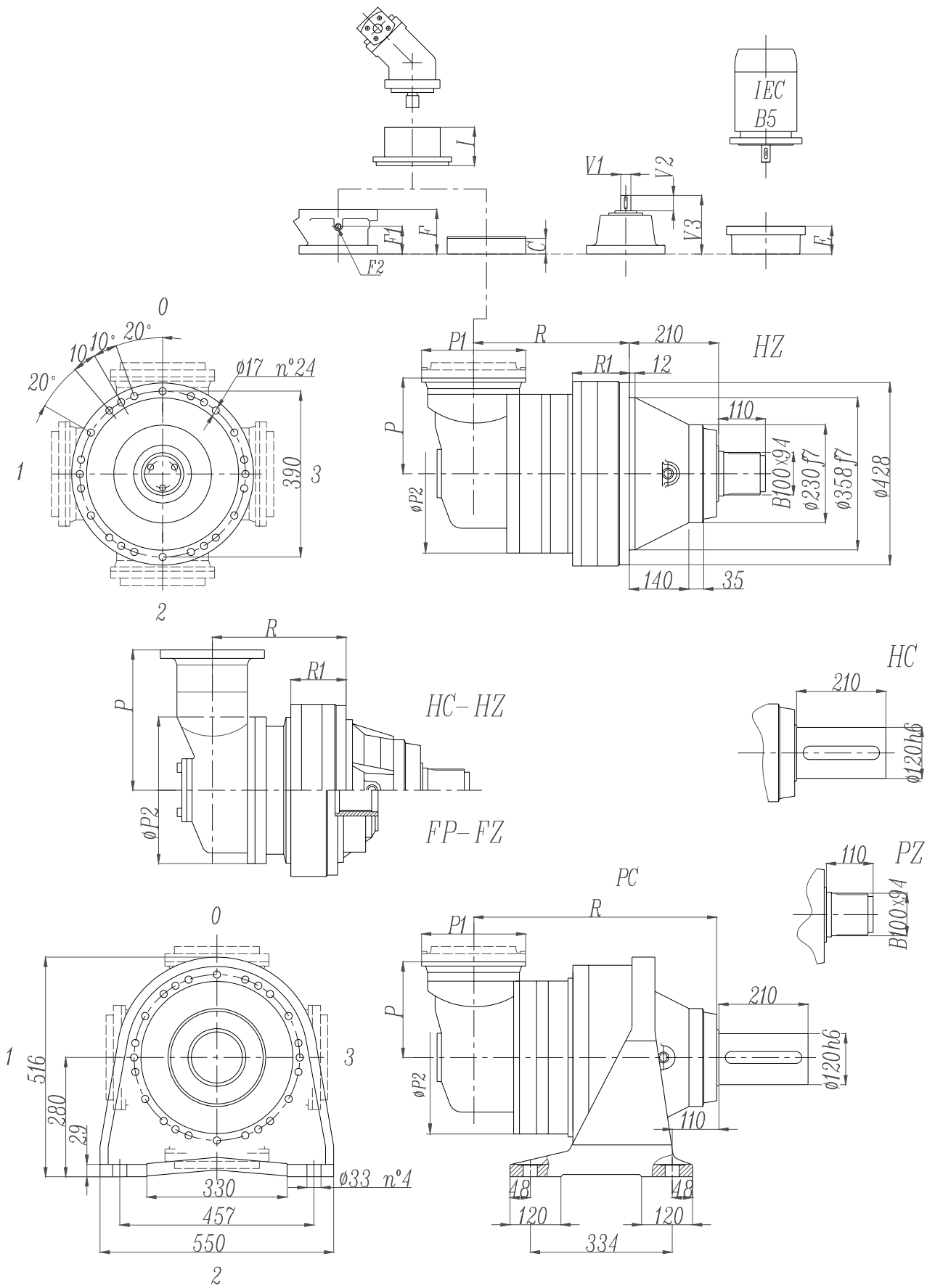

EP311 R

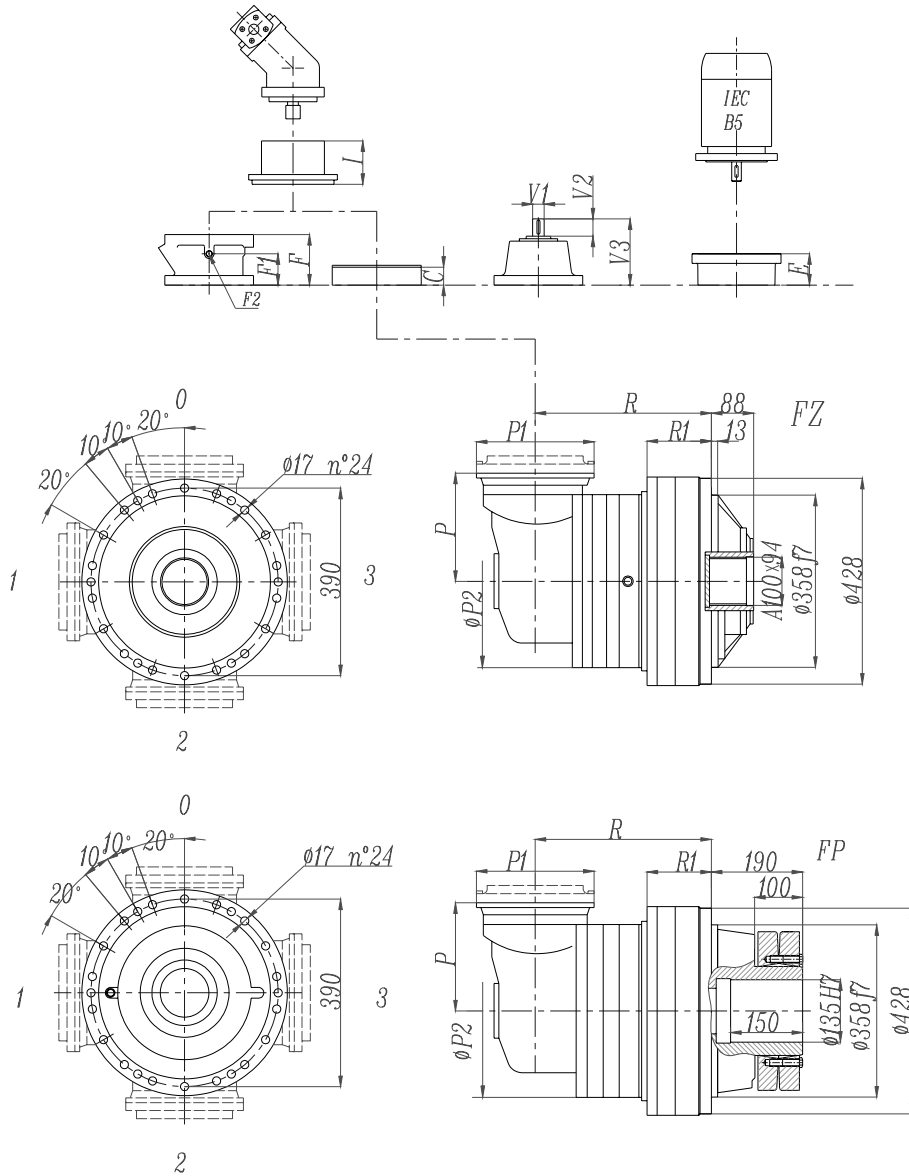

FP version
Max. transmissible
54000 N.m

	R				Ref. weight (without input) (Kg)				C	P	I	Brake				
	HZ HC	PC PZ	FZ	FP	HZ HC	PC PZ	FZ	FP				F	F1	F2	Type	Ref. Weight 15 Kg
311 R2	340	550	340	340	320	390	300	310	45	345	According to hydraulic motor	195	147	1/4 G	6	38
311 R3	367	577	367	367	275	345	255	265	37	140		145	95	1/4 G	4	22
311 R4	433	641	433	433	257	331	241	251	37	140		105	65	1/4 G	4	15

	P1	E (IEC motor input)														
		HZ	HC	FZ	FP	IEC 71	IEC 80	IEC 90	IEC 100	IEC 112	IEC 132	IEC 160	IEC 180	IEC 200	IEC 225	IEC 250
311 R2	292	154	154	154	154								152	182	212	193
311 R3	245	130	130	110	110						114	144	144	174	174	
311 R4	186	130	130	110	110	65	84	84	94	94	114	144				

EP311 L - EP311 R

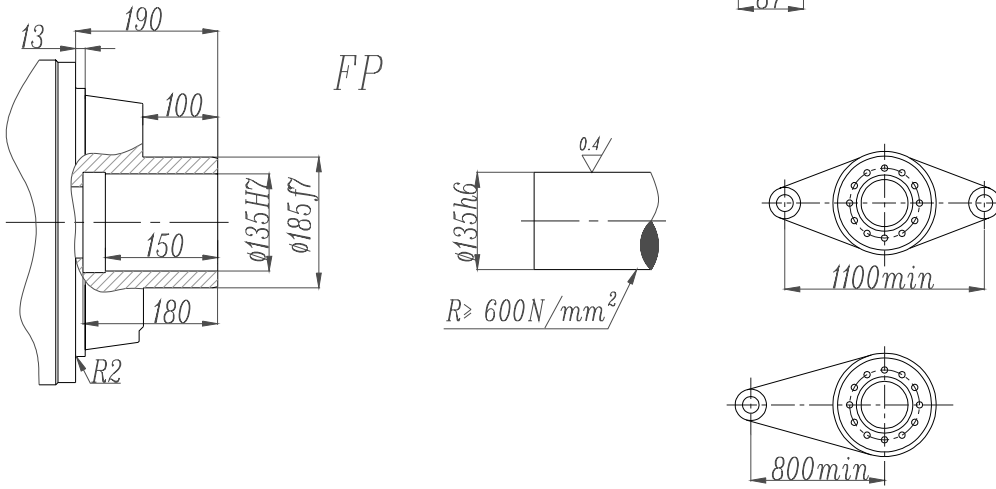
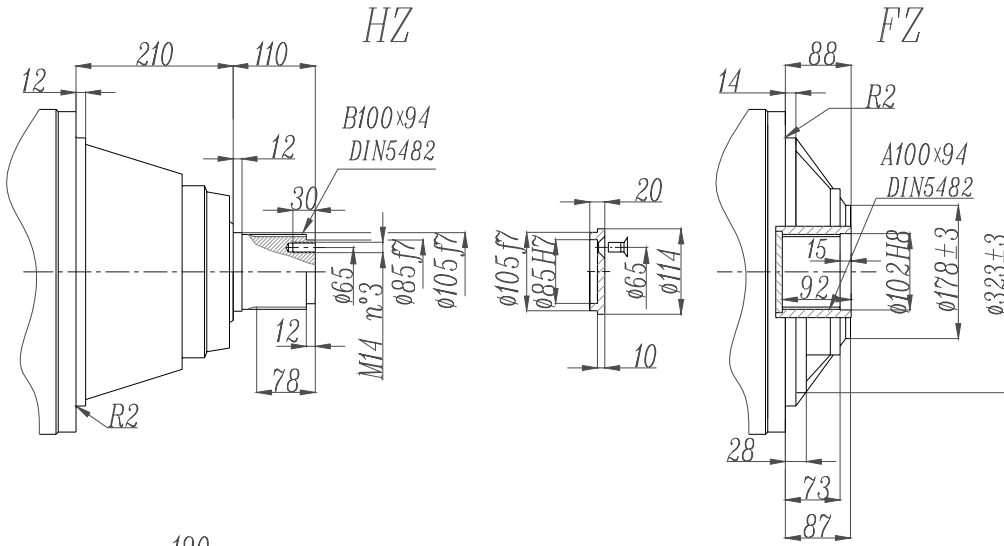
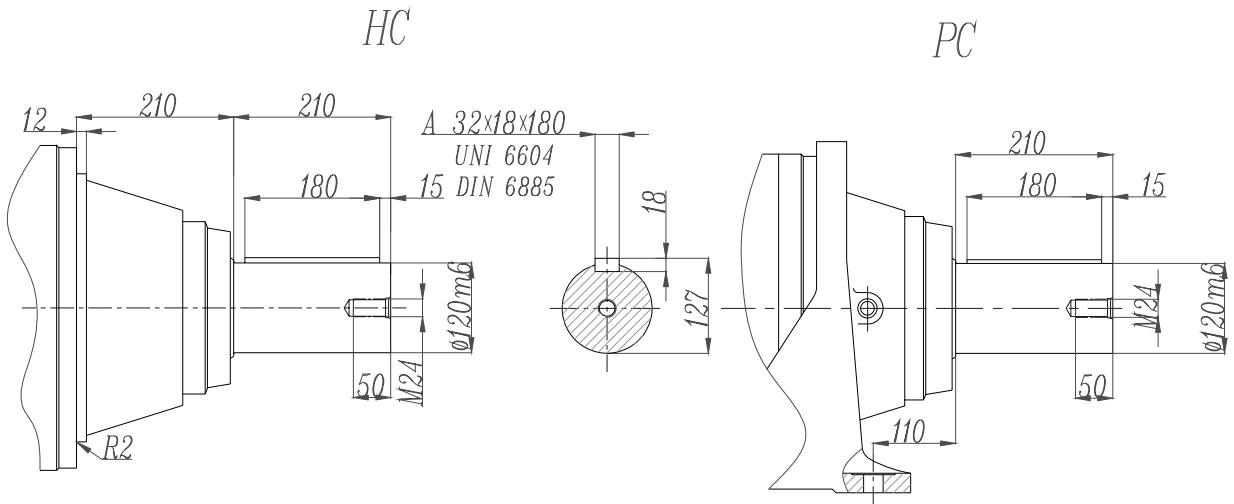

FP version

Max. transmissible

54000 N.m

EP311 L - EP311 R

Ø120mm

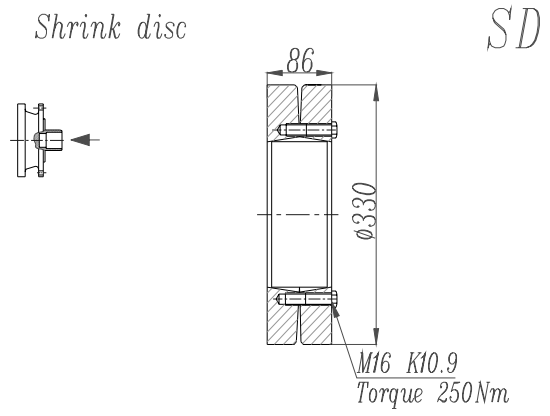
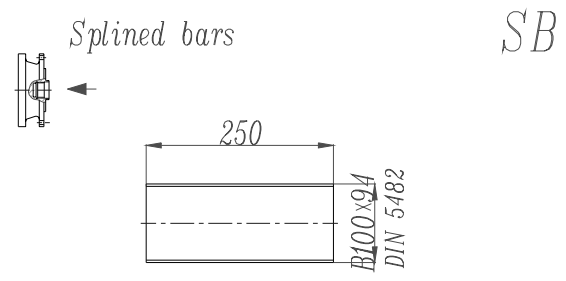
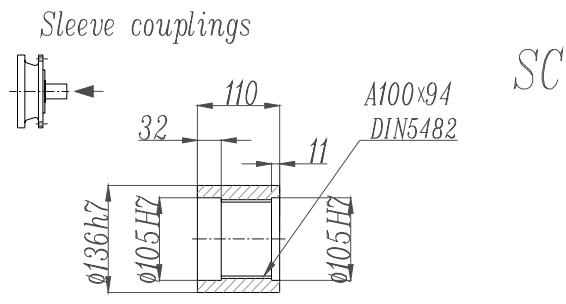
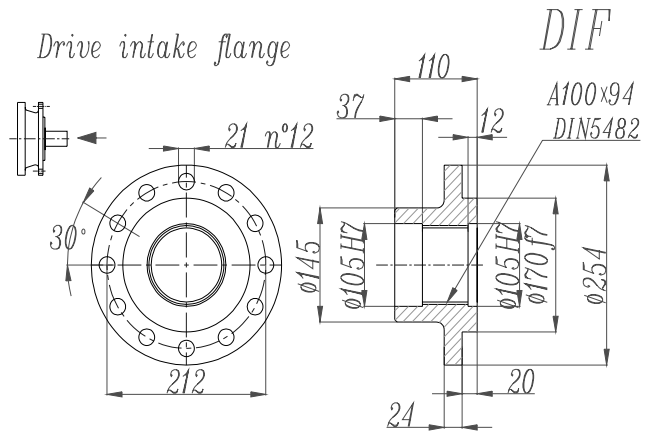

EP311 L - EP311 R

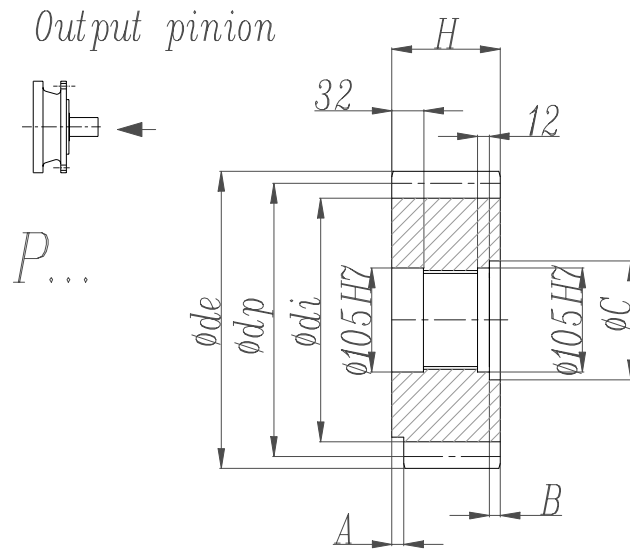

	m	z	x	dp	di	de	H	A	B	C
PLQ	12	23	0	276	246	300	110	0	0	0
PPD	16	13	0.5000	208	184	252.5	145	0	35	116
PPF	16	15	0.450	240	215	280	125	0	15	120

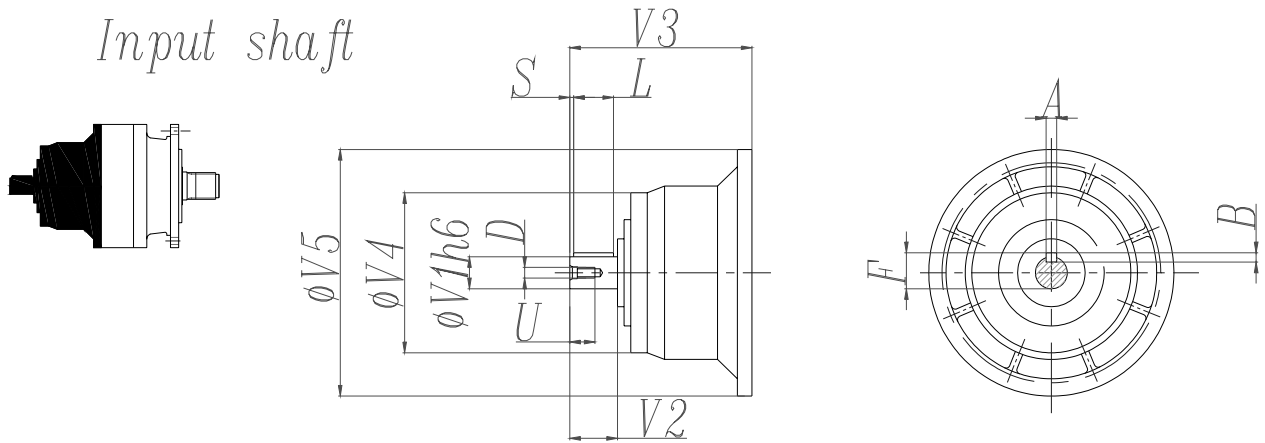

	CODE	V1	V2	V3	V4	V5	A	B	F	L	S	D	U
311 L1	V11B	80	130	348	200	428	22	14	85	110	10	M16	36
311 L2	V07B	80	130	315	200	345	22	14	85	110	105	M16	36
	V07A	60	105	313	155	345	18	11	64	90	7.5	M16	36
311 L3	V05B	48	82	239	155	245	14	9	51.5	70	6	M16	36
311 L4	V01A	24	36	137.5	120	186	8	7	27	30	3	M8	19
	V01B	38	58	158	120	186	10	8	41	50	4	M12	28
311 R2	V06B	60	105	307	155	292	18	11	64	90	7.5	M16	36
311 R3-R4	V01A	24	36	137.5	120	186	8	7	27	30	3	M8	19
	V01B	38	58	158	120	186	10	8	41	50	4	M12	28

EP311 L - EP311 R

Permissible radial and axial loads on output shaft with Fh2 (n2 • h=10 000)

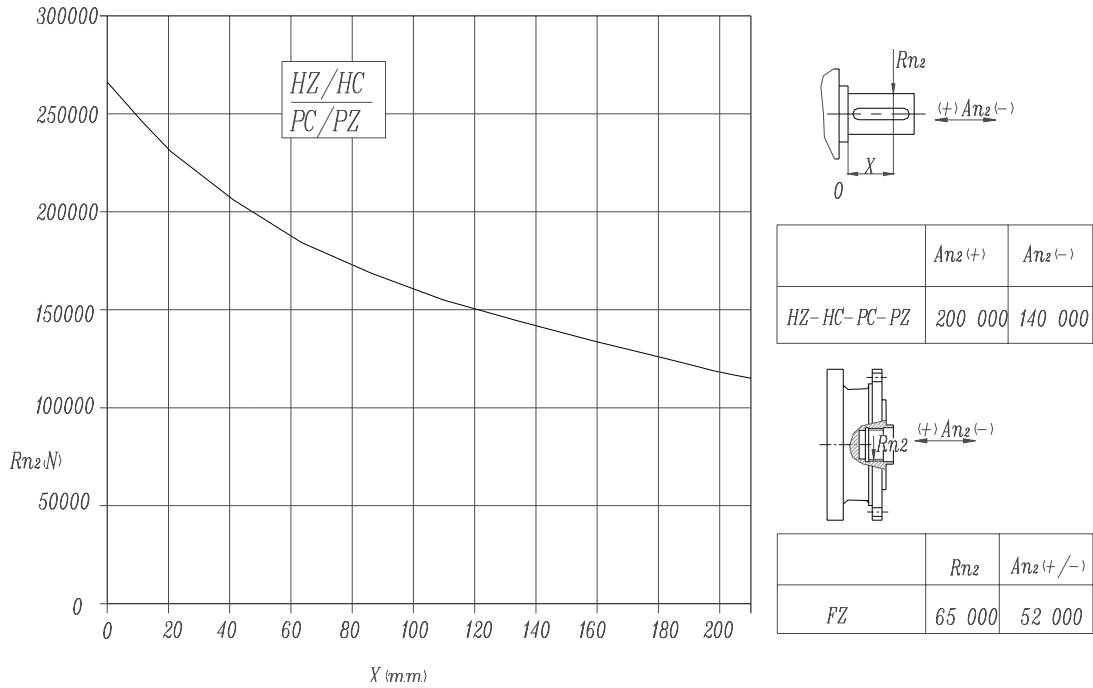

Load corrective factor fh2 on shafts	fh2= n2 • h		10 000	25 000	50 000	100 000	500 000	1 000 000
	fh2	MZ-MC-PC-PZ-FZ	1	0.74	0.58	0.46	0.27	0.21
	HZ-HC	1	0.76	0.61	0.50	0.31	0.25	

Permissible radial loads on input shaft with Fh1 (n1 • h=250 000)

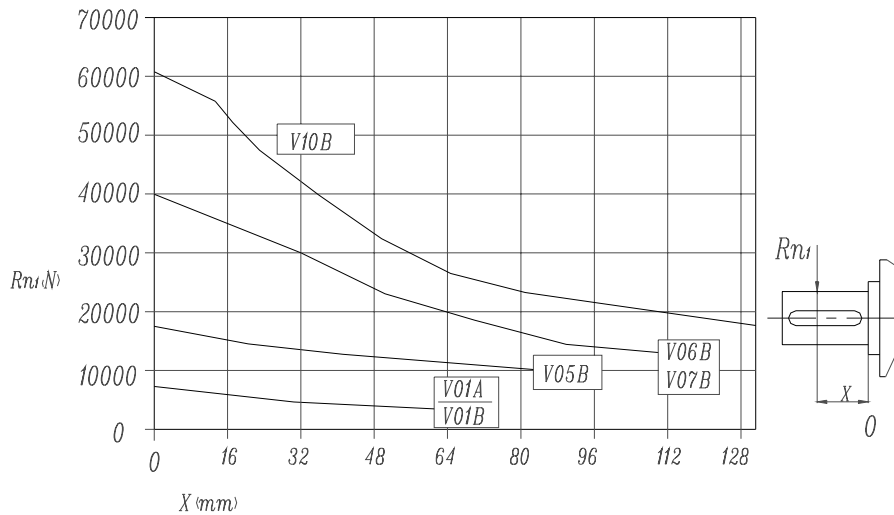

Load corrective factor fh1 on shafts	Fh1= n1 • h		250 000	500 000	1 000 000	2 00 000	5 000 000	10 000 000
	fh1		1	0.79	0.63	0.50	0.37	0.29

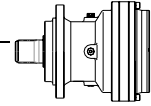

EP313L

M2'=50000N.m

	I 1:	Mn ₂ (N.m)						P ₁ (KW)	P _t (KW) (ta=20°C) (n ₁ =1500)	n ₁ (min ⁻¹)	n _{1max} (min ⁻¹)	M _b (N.m)	Brake type
		n ₂ .h 10000	n ₂ .h 25000	n ₂ .h 50000	n ₂ .h 100000	n ₂ .h 500000	n ₂ .h 1000000						
L1	4.0	55000	55000	55000	46000	28400	23000	200	45	500	800		
	5.7	55000	48000	45000	45000	27800	22600	200	45	500	800		
	6.5	49000	42400	39000	39000	27800	22500	200	45	500	800		
L2	13.7	55000	55000	55000	46000	28400	23000	130	30	1500	2500	3200	6L
	17.6	55000	55000	55000	46000	28400	23000	130	30	1500	2500	3200	6L
	22.6	55000	48000	45000	45000	27800	22600	130	30	1500	2500	3200	6L
	26.9	55000	48000	45000	45000	27800	22600	130	30	1500	2500	3200	6L
	31.9	55000	48000	45000	45000	27800	22600	120	30	1500	2500	2600	6K
	37.9	49000	42400	39000	39000	27800	22500	110	30	1500	2500	2100	6G
	50.3	55000	55000	55000	46000	28400	23000	80	18	1750	3 500	1000	5K
L3	64.5	55000	55000	55000	46000	28400	23000	65	18	1750	3 500	1000	5K
	73.9	55000	55000	55000	46000	28400	23000	60	18	1750	3 500	1000	5K
	82.7	55000	48000	45000	45000	27800	22600	58	18	1750	3 500	1000	5K
	94.7	55000	48000	45000	45000	27800	22600	55	18	1750	3 500	800	5G
	113	55000	48000	45000	45000	27800	22600	55	18	1750	3 500	800	5G
	135	55000	48000	45000	45000	27800	22600	50	18	1750	3 500	800	5G
	150	55000	48000	45000	45000	27800	22600	45	18	1750	3 500	500	5C
	183	55000	48000	45000	45000	27800	22600	40	18	1750	3 500	400	5B
	218	55000	48000	45000	45000	27800	22600	36	18	1750	3 500	400	5B
	258	49000	42400	39000	39000	27800	22500	31	18	1750	3 500	400	5B
L4	250	55000	55000	55000	46000	28400	23000	30	11	1750	3 500	330	4H
	280	55000	48000	45000	45000	27800	22600	30	11	1750	3 500	330	4H
	329	55000	55000	55000	46000	28400	23000	28	11	1750	3 500	260	4F
	426	55000	55000	55000	46000	28400	23000	22	11	1750	3 500	260	4F
	546	55000	48000	45000	45000	27800	22600	15	11	1750	3 500	160	4D
	650	55000	48000	45000	45000	27800	22600	12.5	11	1750	3 500	160	4D
	776	55000	48000	45000	45000	27800	22600	10	11	1750	3 500	100	4B
	865	55000	48000	45000	45000	27800	22600	9	11	1750	3 500	100	4B
	1079	55000	48000	45000	45000	27800	22600	8	11	1750	3 500	100	4B
	1321	55000	48000	45000	45000	27800	22600	6.7	11	1750	3 500	100	4B
1568	55000	48000	45000	45000	27800	22600	5.7	11	1750	3 500	50	4A	
1859	49000	42400	39000	39000	27800	22500	4.5	11	1750	3 500	50	4A	

M_{2max}=1.2×Mn₂(n₂×h=10 000)

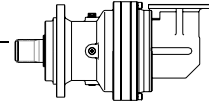

EP313R

M2'=50000N.m

	I 1:	Mn ₂ (N.m)						P ₁ (KW)	P _t (KW) (ta=20°C) (n ₁ =1500)	n ₁ (min ⁻¹)	n _{1max} (min ⁻¹)	M _b (N.m)	Brake type
		n ₂ .h 10000	n ₂ .h 25000	n ₂ .h 50000	n ₂ .h 100000	n ₂ .h 500000	n ₂ .h 1000000						
R2	11.7	28000	27000	25000	24000	16000	12500	150	75	1500	2 500	3200	6L
	16.7	35000	33000	31000	30000	18000	15000	150	75	1500	2 500	3200	6L
	19.0	44000	40000	37000	36000	22000	17000	150	75	1500	2 500	3200	6L
R3	51.9	34000	29500	27000	27000	18600	15100	70	40	1750	3 500	800	5G
	66.6	45000	45000	37400	32000	19700	16000	60	40	1750	3 500	800	5G
	85.4	55000	48000	45000	45000	27800	22600	60	40	1750	3 500	800	5G
	102	55000	48000	45000	45000	27800	22600	50	40	1750	3 500	630	5E
	121	55000	48000	45000	45000	27800	22600	45	40	1750	3 500	630	5E
	143	49000	42400	39000	39000	27800	22500	40	40	1750	3 500	500	5C
R4	129	49000	42400	39000	39000	27800	22500	35	22	1750	3 500	400	4K
	165	55000	55000	55000	46000	28400	23000	35	22	1750	3 500	400	4K
	189	55000	55000	55000	46000	28400	23000	35	22	1750	3 500	330	4H
	212	55000	48000	45000	45000	27800	22600	35	22	1750	3 500	330	4H
	243	55000	48000	45000	45000	27800	22600	31	22	1750	3 500	330	4H
	289	55000	48000	45000	45000	27800	22600	27	22	1750	3 500	260	4F
	345	55000	48000	45000	45000	27800	22600	23	22	1750	3 500	260	4F
	384	55000	48000	45000	45000	27800	22600	21	22	1750	3 500	160	4D
	470	55000	48000	45000	45000	27800	22600	17.5	22	1750	3 500	160	4D
	558	55000	48000	45000	45000	27800	22600	15	22	1750	3 500	160	4D
	662	49000	42400	39000	39000	27800	22500	11	22	1750	3 500	100	4B

M_{2max}=1.2×Mn₂(n₂×h=10 000)

EP313 L

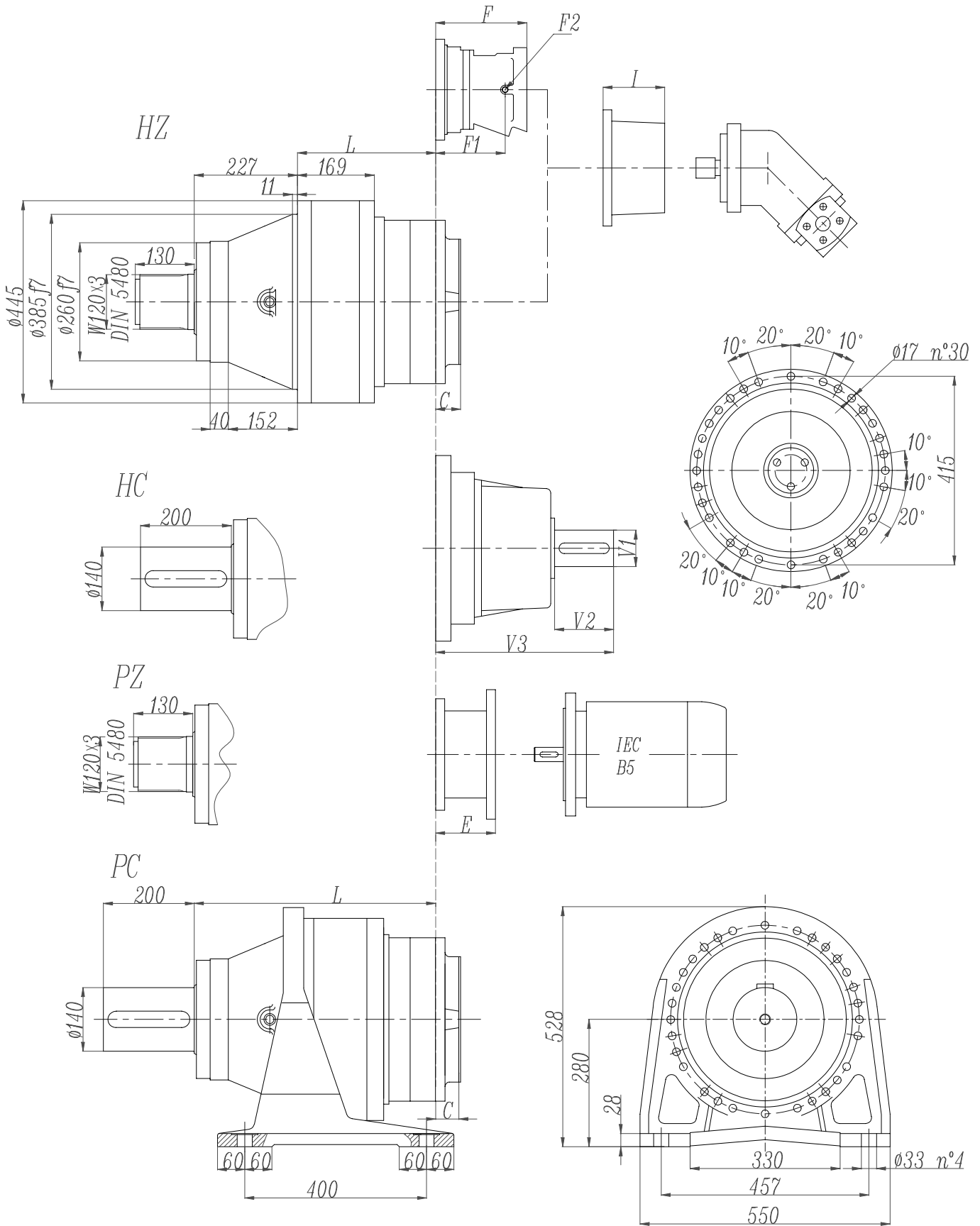

EP313 L

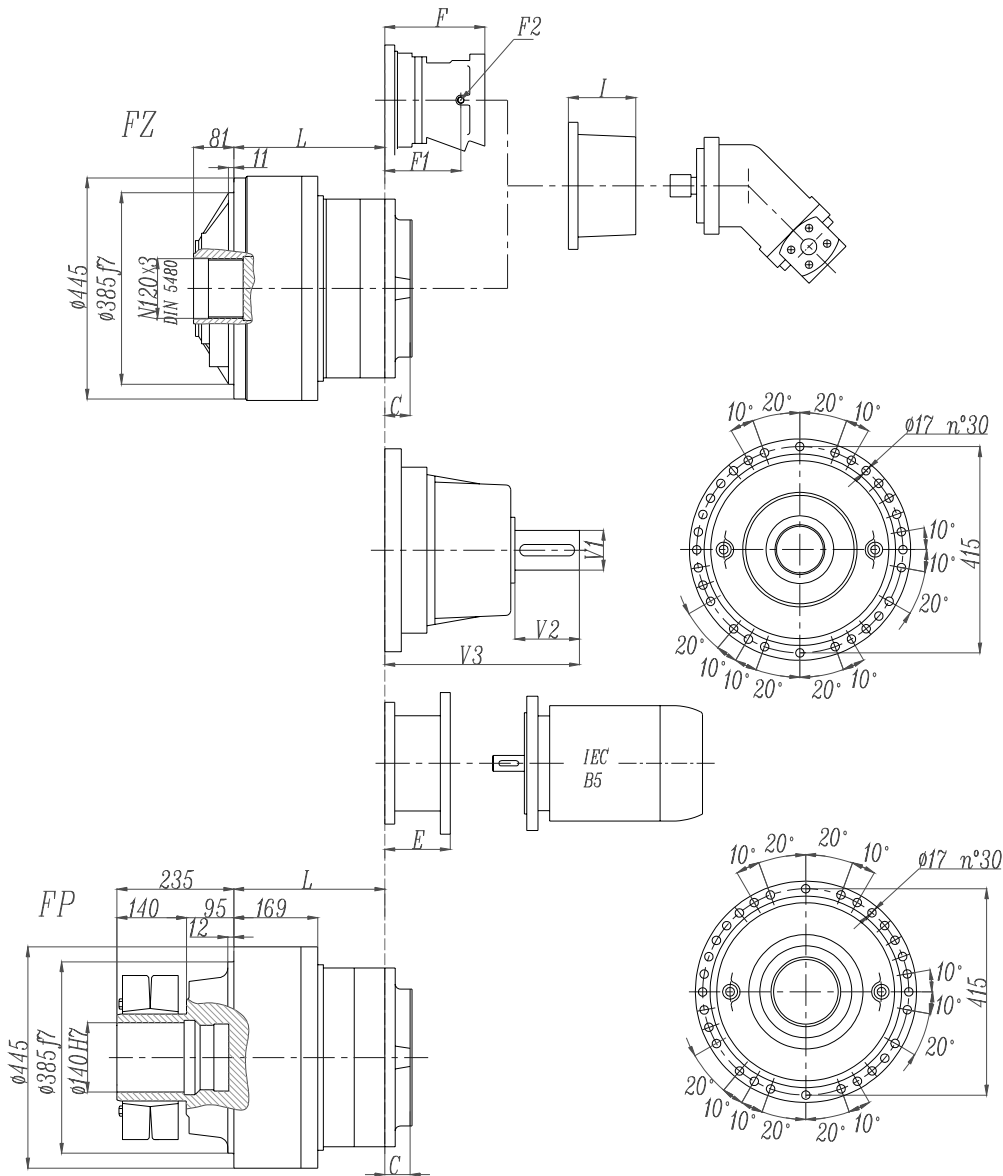

	L				Ref. weight (without input) (Kg)				C	I	Brake				
	HZ HC	PC PZ	FZ	FP	HZ HC	PC PZ	FZ	FP			F	F1	F2	Type	Ref. Weight
313 L1	154	381	154	154	230	320	200	200	76	According to hydraulic motor					
313 L2	304	531	304	304	290	380	260	280	51		201	153	1/4 G	6	38 Kg
313 L3	397	624	397	397	302	392	272	292	37		145	95	1/4 G	5	22 Kg
313 L4	462	689	462	462	309	400	279	300	37		105	65	1/4 G	4	15 Kg

	E (IEC motor input)												
	IEC 71	IEC 80	IEC 90	IEC 100	IEC 112	IEC 132	IEC 160	IEC 180	IEC 200	IEC 225	IEC 250		
313 L1													
313 L2								195	186	216	215		
313 L3						114	144	144	174				
313 L4	65	84	84	94	94	114	144						

EP313 R

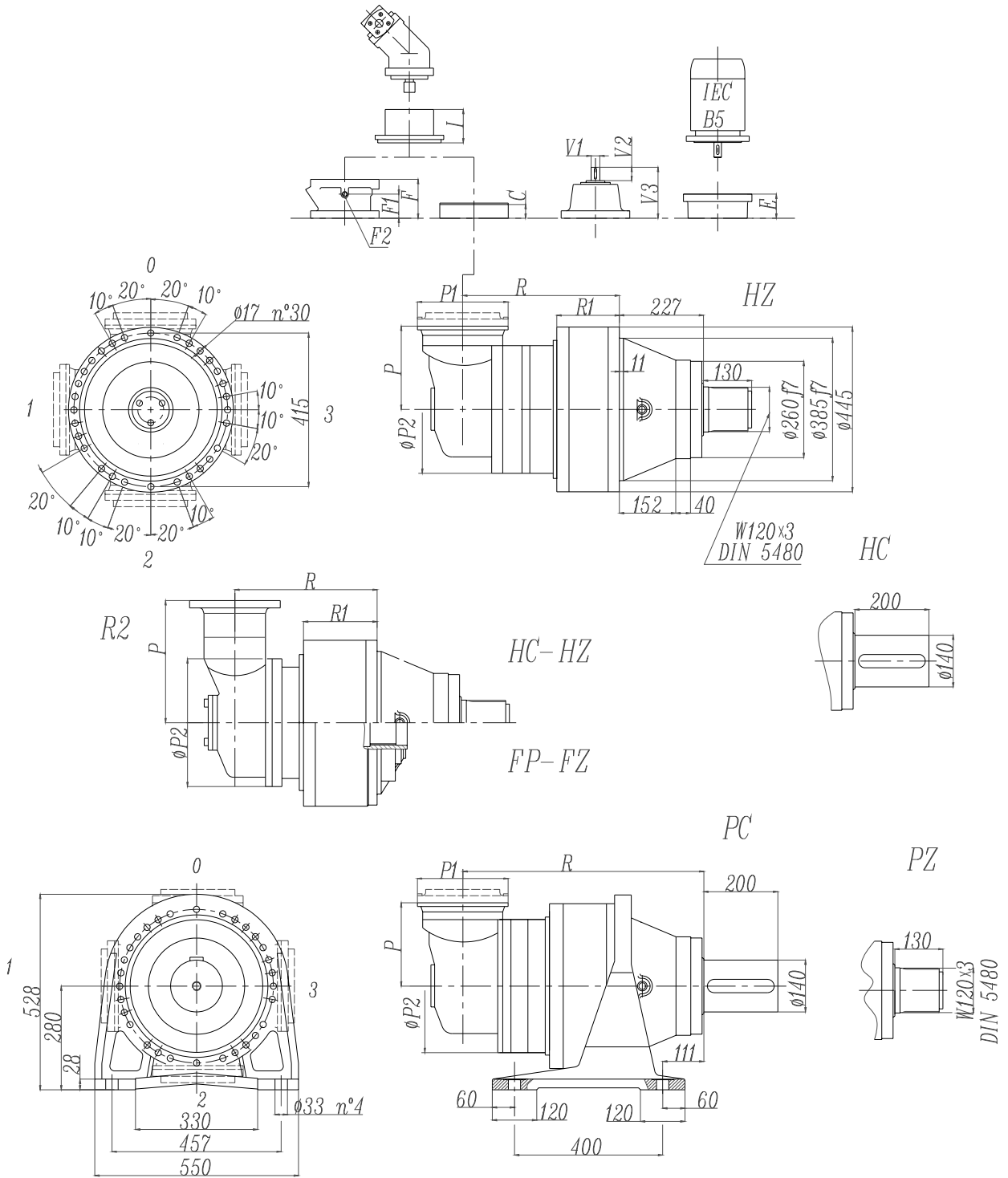

EP313 R

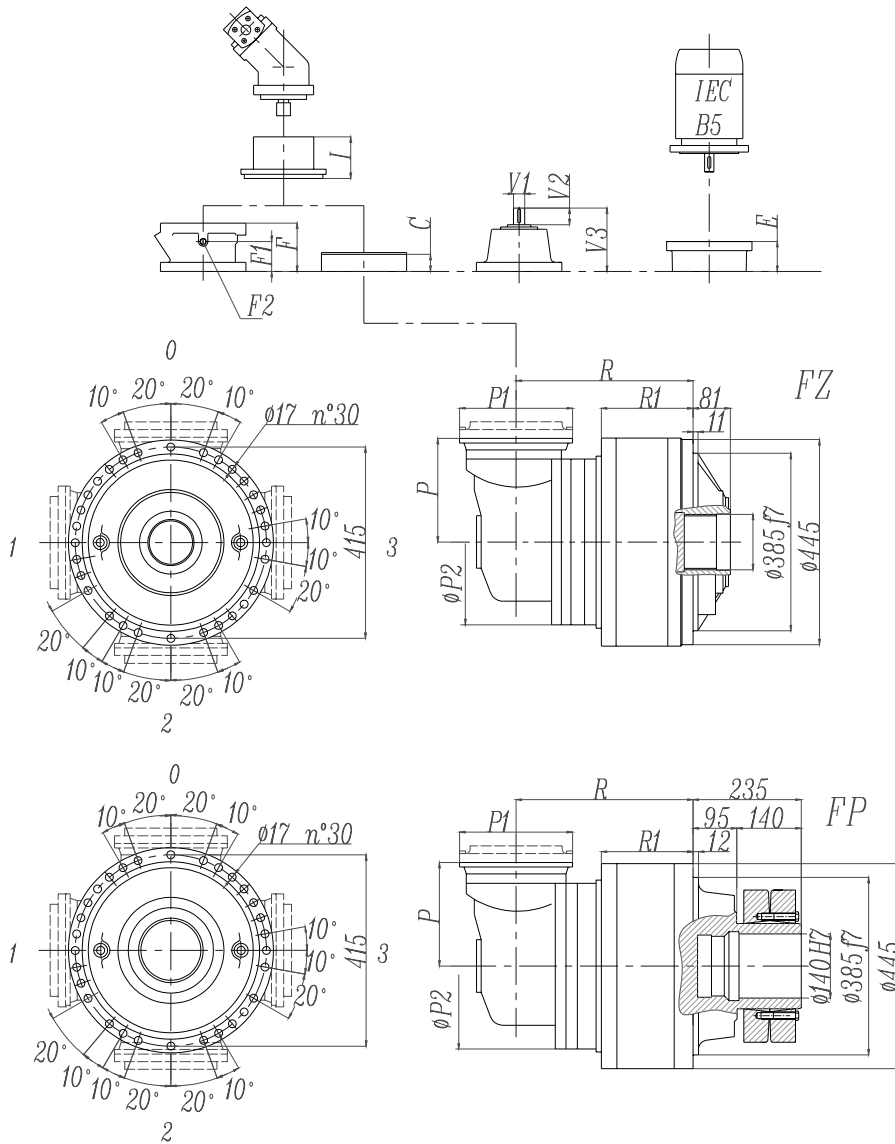

FP version
Max. transmissible
66000 N.m

	R				Ref. weight (without input) (Kg)				C	P	I	Brake				
	HZ HC	PC PZ	FZ	FP	HZ HC	PC PZ	FZ	FP				F	F1	F2	Type	Ref. Weight 15 Kg
313 R2	384	611	384	384	370	460	340	360	45	395	According to hydraulic motor	195	147	1/4 G	6	38
313 R3	423	650	423	423	340	430	310	330	37	225		145	95	1/4 G	4	22
313 R4	485	712	485	485	322	412	292	312	37	140		105	65	1/4 G	4	15

	P1	E (IEC motor input)														
		HZ	HC	FZ	FP	IEC 71	IEC 80	IEC 90	IEC 100	IEC 112	IEC 132	IEC 160	IEC 180	IEC 200	IEC 225	IEC 250
313 R2	292	154	154	154	154								152	182	212	193
313 R3	245	130	130	110	110						114	144	144	174	174	
313 R4	186	130	130	110	110	65	84	84	94	94	114	144				

EP313 L - EP313 R

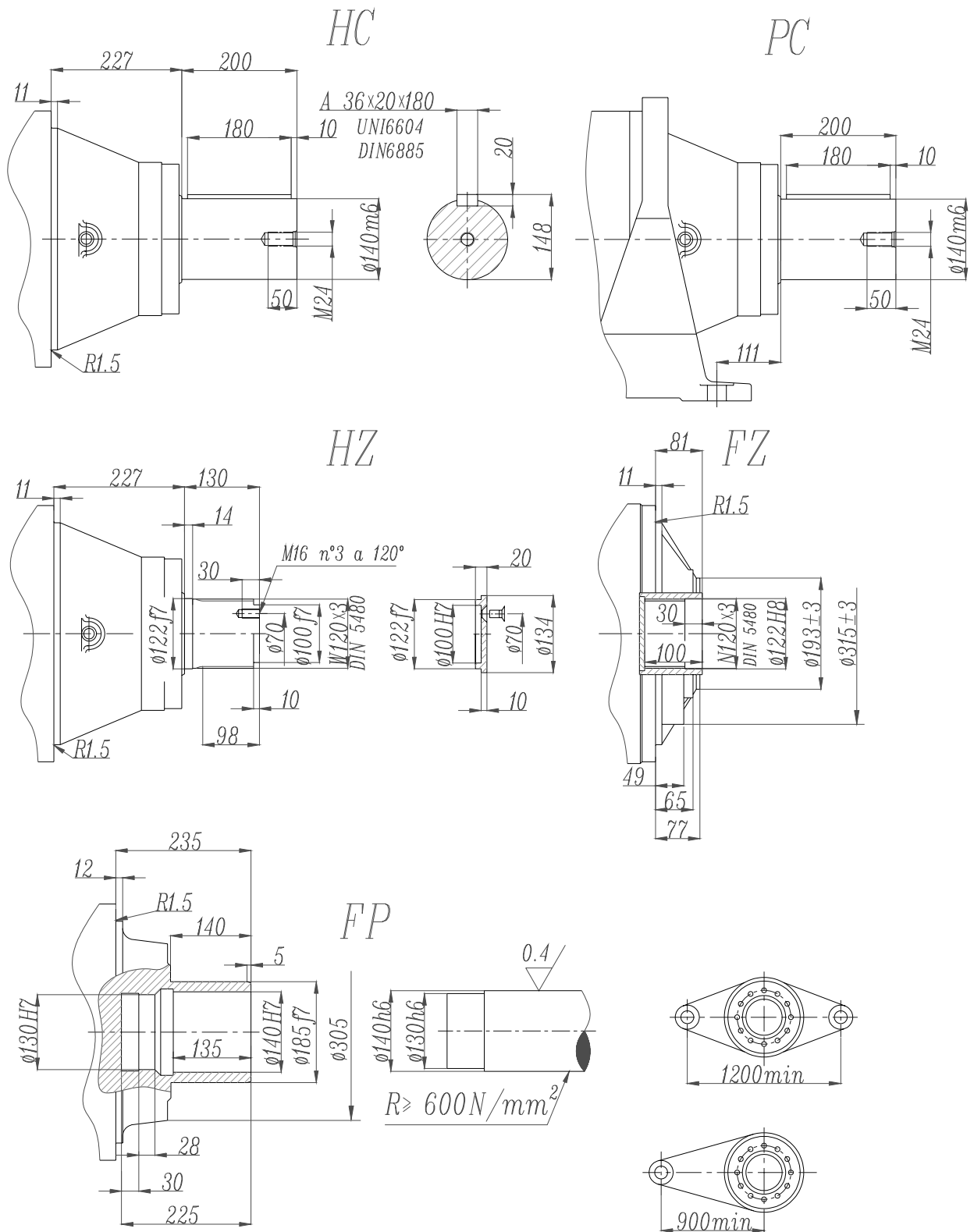

FP version

Max. transmissible

66000 N.m

EP313 L - EP313 R

Drive intake flange

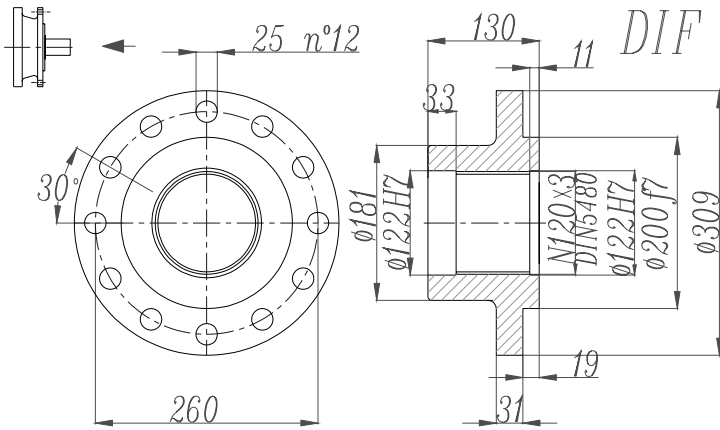

Sleeve couplings

SC

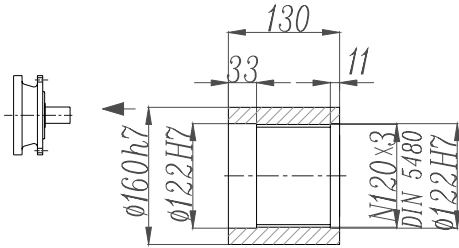

Splined bars

SB

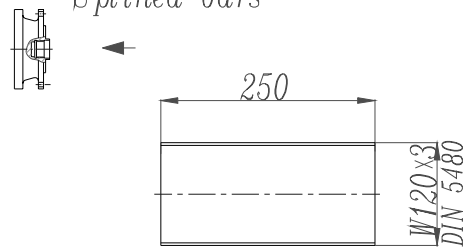

Shrink disc

SD

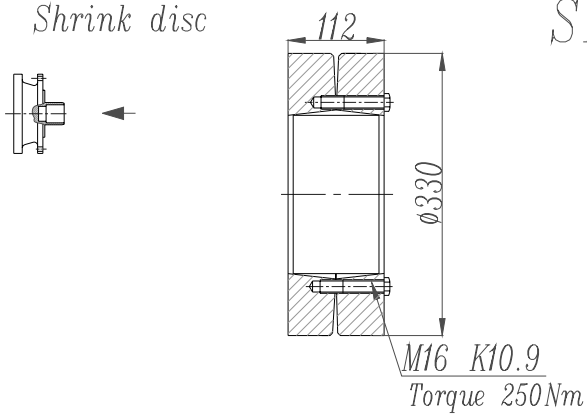

EP313 L - EP313 R

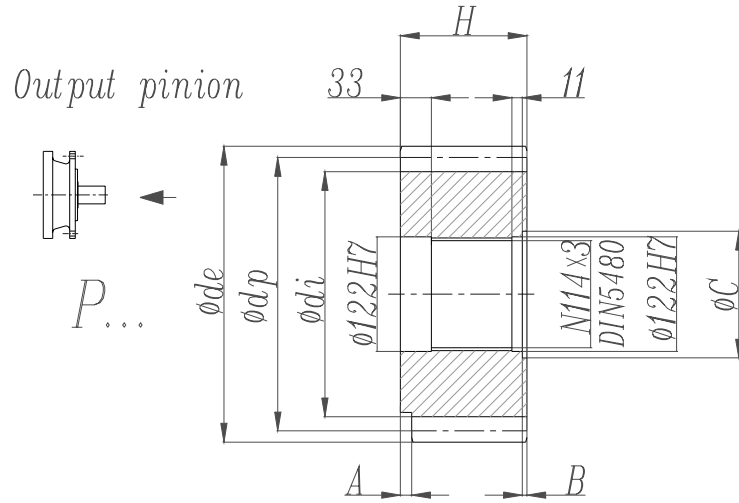

	m	z	x	dp	di	de	H	A	B	C
PRH	16	17	0.500	272	247	315	135	0	5	136
PRI	18	18	0.333	324	294	365	140	0	10	140

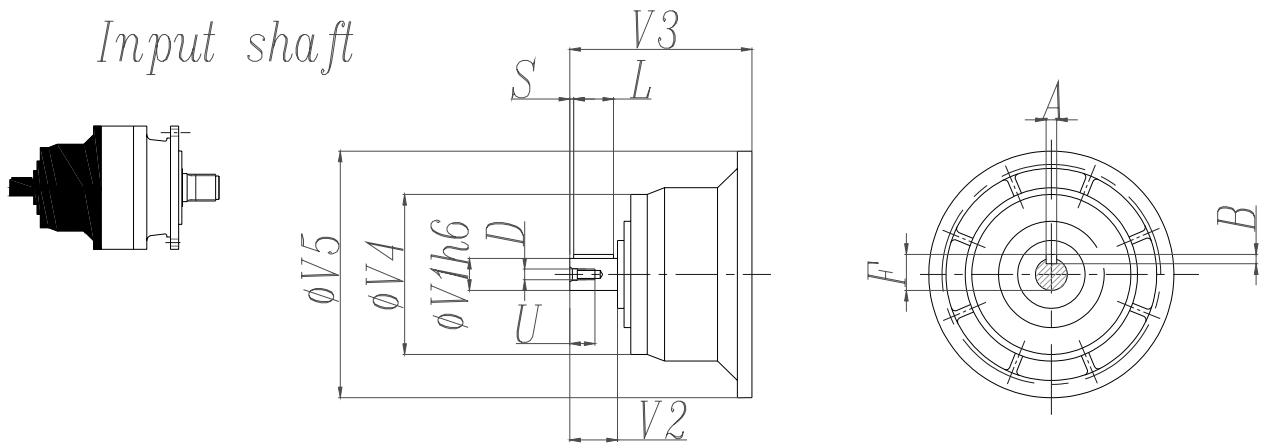

	CODE	V1	V2	V3	V4	V5	A	B	F	L	S	D	U
313 L1	V11B	80	130	348	200	428	22	14	85	110	10	M16	36
313 L2	V07B	80	130	315	200	345	22	14	85	110	105	M16	36
	V07A	60	105	313	155	345	18	11	64	90	7.5	M16	36
313 L3	V05B	48	82	239	155	245	14	9	51.5	70	6	M16	36
313 L4	V01A	24	36	137.5	120	186	8	7	27	30	3	M8	19
	V01B	38	58	158	120	186	10	8	41	50	4	M12	28
313 R2	V06B	60	105	307	155	292	18	11	64	90	7.5	M16	36
313 R3-R4	V01A	24	36	137.5	120	186	8	7	27	30	3	M8	19
	V01B	38	58	158	120	186	10	8	41	50	4	M12	28

EP313 L - EP313 R

Permissible radial and axial loads on output shaft with Fh2 ($n_2 \cdot h=10\ 000$)

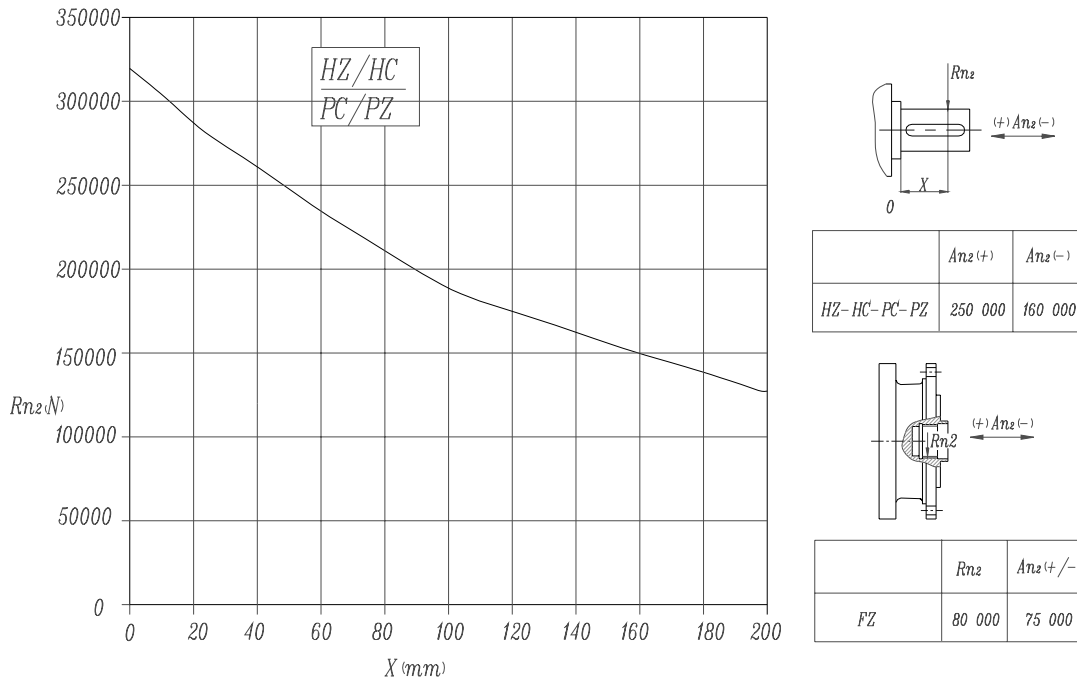

Load corrective factor fh2 on shafts	fh2= $n_2 \cdot h$		10 000	25 000	50 000	100 000	500 000	1 000 000
		fh2	MZ-MC-PC-PZ-FZ	1	0.74	0.58	0.46	0.27
		HZ-HC	1	0.76	0.61	0.50	0.31	0.25

Permissible radial loads on input shaft with Fh1 ($n_1 \cdot h=250\ 000$)

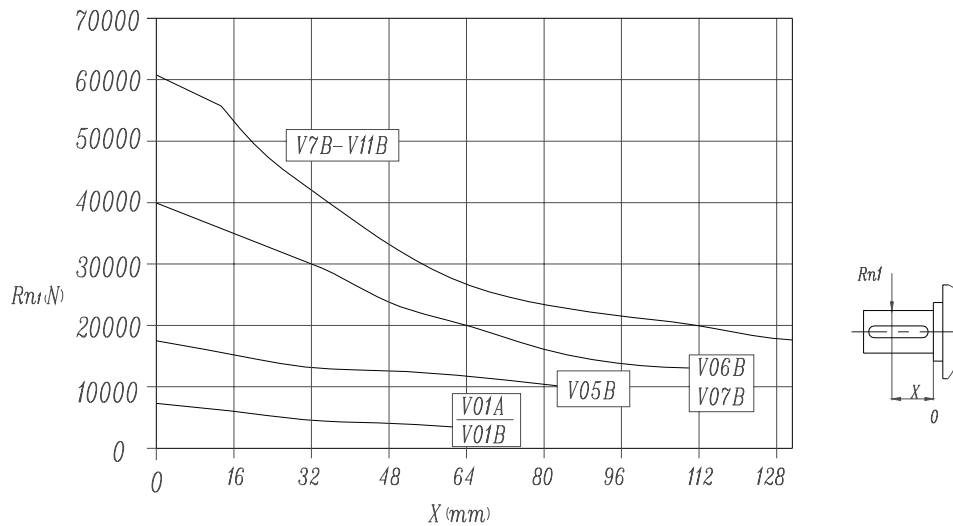

Load corrective factor fh1 on shafts	Fh1= $n_1 \cdot h$		250 000	500 000	1 000 000	2 00 000	5 000 000	10 000 000
		fh1		1	0.79	0.63	0.50	0.37

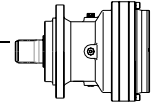

EP315L

M2'=80000N.m

	I 1:	Mn ₂ (N.m)						P ₁ (KW)	P _t (KW) (ta=20°C) (n ₁ =1500)	n ₁ (min ⁻¹)	n _{1max} (min ⁻¹)	M _b (N.m)	Brake type
		n ₂ .h 10000	n ₂ .h 25000	n ₂ .h 50000	n ₂ .h 100000	n ₂ .h 500000	n ₂ .h 1000000						
L1	3.8	105000	100000	97000	85000	53000	42800	260	60	350	500		
	4.4	99000	87000	79000	78000	49000	39700	260	60	350	500		
	5.3	90000	80000	70000	68000	42000	34000	260	60	350	500		
	6.2	80000	70000	65000	65000	41000	33000	230	60	350	500		
L2	16.1	105000	100000	97000	85000	53000	42800	180	45	750	1000		
	18.5	99000	87000	79000	78000	49000	39700	180	45	750	1000		
	22.0	99000	87000	79000	78000	49000	39700	180	45	750	1000		
	26.3	90000	80000	70000	68000	42000	34000	170	45	750	1000		
	31.2	80000	70000	65000	65000	41000	33000	140	45	750	1000		
	35.8	90000	80000	70000	68000	42000	34000	120	45	750	1000		
	42.5	80000	70000	65000	65000	41000	33000	100	45	750	1000		
L3	59.2	105000	100000	97000	85000	53000	42800	100	30	1500	2500	2600	6K
	67.5	105000	100000	97000	85000	53000	42800	100	30	1500	2500	2100	6G
	77.4	99000	87000	79000	78000	49000	39700	100	30	1500	2500	2100	6G
	92.2	99000	87000	79000	78000	49000	39700	100	30	1500	2500	1500	6E
	109	99000	87000	79000	78000	49000	39700	90	30	1500	2500	1500	6E
	127	99000	87000	79000	78000	49000	39700	80	30	1500	2500	1100	6C
	152	90000	80000	70000	68000	42000	34000	65	30	1500	2500	1100	6C
	180	80000	70000	65000	65000	41000	33000	55	30	1500	2500	850	6B
	207	90000	80000	70000	68000	42000	34000	50	30	1500	2500	850	6B
	254	90000	80000	70000	68000	42000	34000	42	30	1500	2500	850	6B
301	80000	70000	65000	65000	41000	33000	32	30	1500	2500	850	6B	
L4	337	105000	100000	97000	85000	53000	42800	50	18	1750	3 500	400	5B
	387	99000	87000	79000	78000	49000	39700	35	18	1750	3 500	400	5B
	461	99000	87000	79000	78000	49000	39700	30	18	1750	3 500	400	5B
	544	99000	87000	79000	78000	49000	39700	26	18	1750	3 500	400	5B
	636	99000	87000	79000	78000	49000	39700	23	18	1750	3 500	400	5B
	709	99000	87000	79000	78000	49000	39700	21	18	1750	3 500	400	5B
	868	99000	87000	79000	78000	49000	39700	17.5	18	1750	3 500	400	5B
	1036	90000	80000	70000	68000	42000	34000	14	18	1750	3 500	400	5B
	1229	80000	70000	65000	65000	41000	33000	10.5	18	1750	3 500	400	5B
	1412	90000	80000	70000	68000	42000	34000	10.5	18	1750	3 500	400	5B
	1731	90000	80000	70000	68000	42000	34000	9	18	1750	3 500	400	5B
2054	80000	70000	65000	65000	41000	33000	7	18	1750	3 500	400	5B	

M_{2max}=1.2×Mn₂(n₂×h=10 000)

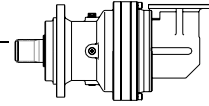

EP315R

M2'=80000N.m

	I 1:	Mn ₂ (N.m)						P ₁ (KW)	P _t (KW) (ta=20°C) (n ₁ =1500)	n ₁ (min ⁻¹)	n _{1max} (min ⁻¹)	M _b (N.m)	Brake type
		n ₂ .h 10000	n ₂ .h 25000	n ₂ .h 50000	n ₂ .h 100000	n ₂ .h 500000	n ₂ .h 1000000						
R3	47.2	73000	73000	60000	48300	29800	24200	150	75	1500	2 500	3200	6L
	54.1	90000	80000	70000	68000	42000	34000	150	75	1500	2 500	2600	6K
	64.4	99000	87000	79000	78000	49000	39700	150	75	1500	2 500	2100	6G
	76.9	90000	80000	70000	68000	42000	34000	125	75	1500	2 500	2100	6G
	91.2	80000	70000	65000	65000	41000	33000	100	75	1500	2 500	1500	6E
	105	90000	80000	70000	68000	42000	34000	90	75	1500	2 500	1500	6E
	124	80000	70000	65000	65000	41000	33000	75	75	1500	2 500	850	6B
R4	152	90000	80000	70000	68000	42000	34000	80	40	1750	3 500	800	5G
	173	105000	10000	97000	85000	53000	42800	80	40	1750	3 500	800	5G
	198	99000	87000	79000	78000	49000	39700	70	40	1750	3 500	800	5G
	236	99000	87000	79000	78000	49000	39700	60	40	1750	3 500	630	5E
	279	99000	87000	79000	78000	49000	39700	50	40	1750	3 500	630	5E
	326	99000	87000	79000	78000	49000	39700	43	40	1750	3 500	500	5C
	389	90000	80000	70000	68000	42000	34000	32	40	1750	3 500	400	5B
	462	80000	70000	65000	65000	41000	33000	26	40	1750	3 500	400	5B
	531	90000	80000	70000	68000	42000	34000	23	40	1750	3 500	400	5B
	650	90000	80000	70000	68000	42000	34000	21	40	1750	3 500	400	5B
	772	80000	70000	65000	65000	41000	33000	16	40	1750	3 500	400	5B

M_{2max}=1.2×Mn₂(n₂×h=10 000)

EP315 L

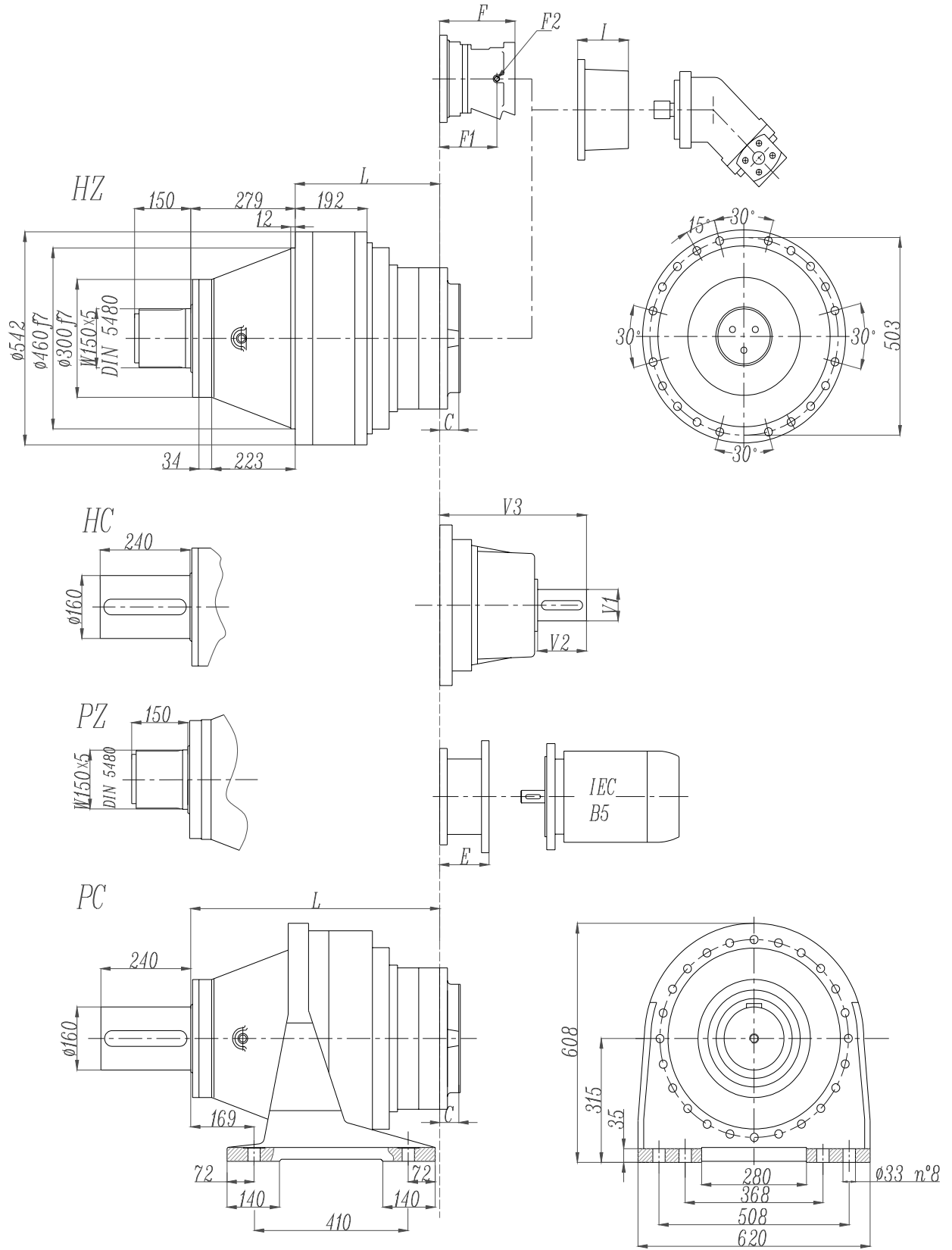

EP315 L

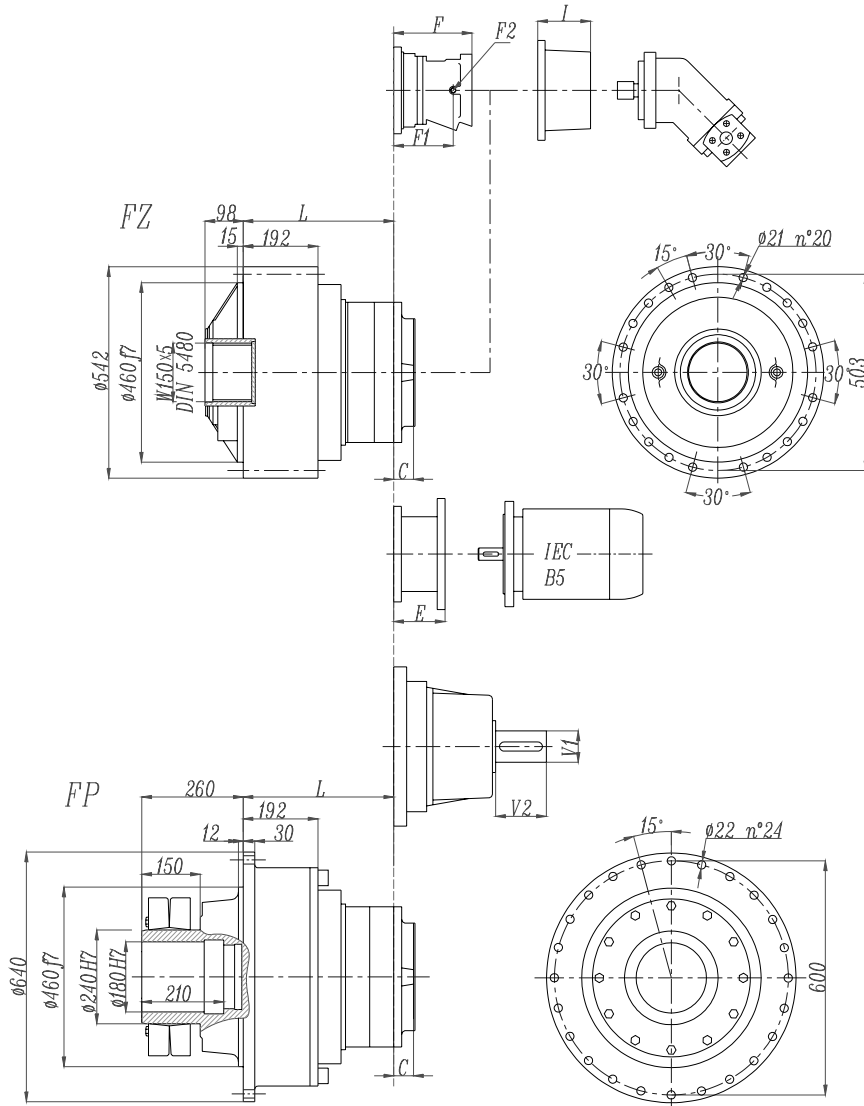

FP version
Max. transmissible
126000 N.m

	L				Ref. weight (without input) (Kg)				C	I	Brake				
	HZ HC	PC PZ	FZ	FP	HZ HC	PC PZ	FZ	FP			F	F1	F2	Type	Ref. Weight
315 L1	174	453	174	174	370	500	280	330	116	According to hydraulic motor					
315 L2	386	665	386	386	455	585	365	415	81		232	185	1/4 G	6	46 Kg
315 L3	519	798	519	519	500	630	410	460	51		201	153	1/4 G	6	38 Kg
315 L4	612	891	612	612	512	642	422	472	37		145	95	1/4 G	5	22 Kg

	E (IEC motor input)															
							IEC 132	IEC 160	IEC 180	IEC 200	IEC 225	IEC 250				
315 L1																
315 L2																
315 L3									195	186	216	215				
315 L4							114	144	114	174						

EP315 R

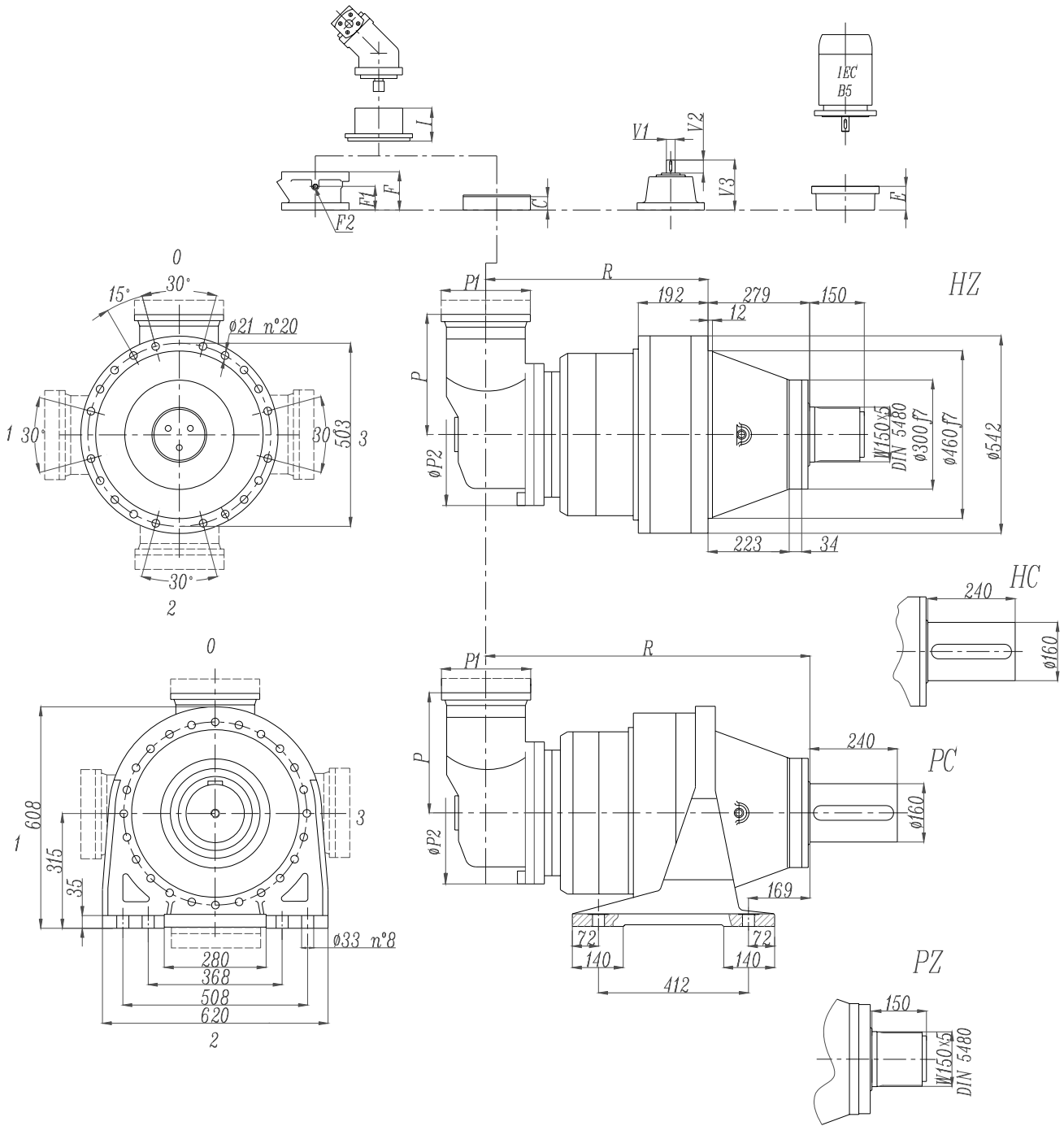

EP315 R

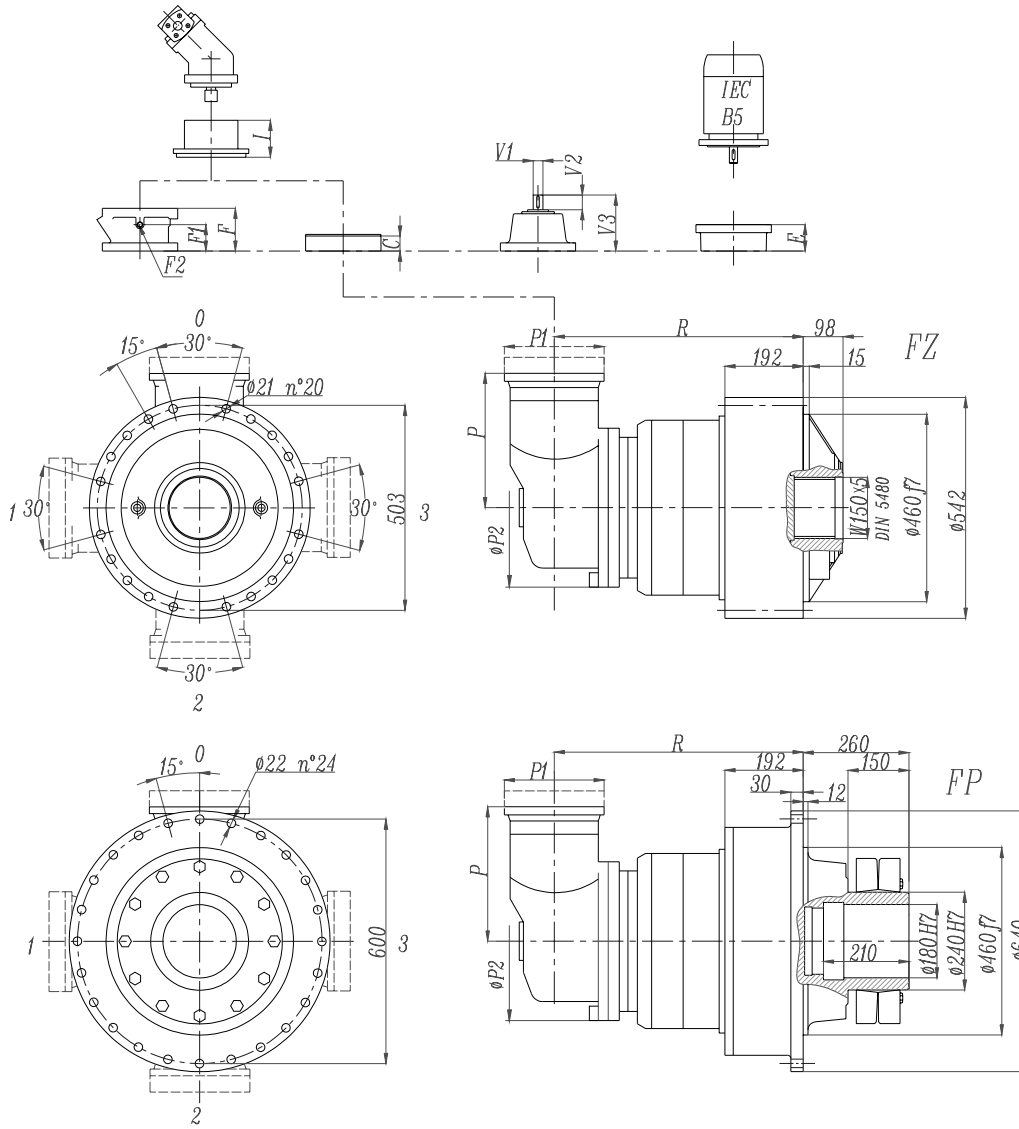

FP version
Max. transmissible
126000 N.m

	R				Ref. weight (without input) (Kg)				C	P	I	Brake				
	HZ HC	PC PZ	FZ	FP	HZ HC	PC PZ	FZ	FP				F	F1	F2	Type	Ref. Weight 15 Kg
315 R3	611	890	611	611	600	730	510	560	45	390	According to hydraulic motor	195	147	1/4 G	6	38
315 R4	642	921	642	642	550	680	460	510	37	225		145	95	1/4 G	4	22

	P1	E (IEC motor input)															
		HZ	HC	FZ	FP	IEC 71	IEC 80	IEC 90	IEC 100	IEC 112	IEC 132	IEC 160	IEC 180	IEC 200	IEC 225	IEC 250	
315 R3	245	130	130	110	110									152	182	212	193
315 R4	186	130	130	110	110						114	144	144	174	174		

EP315 L - EP315 R

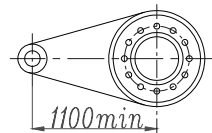
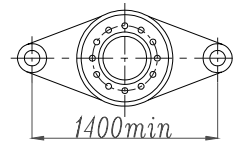
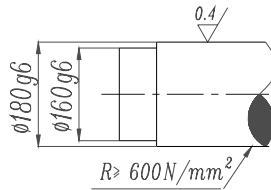
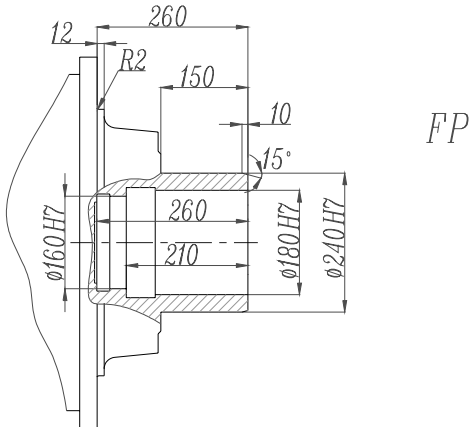
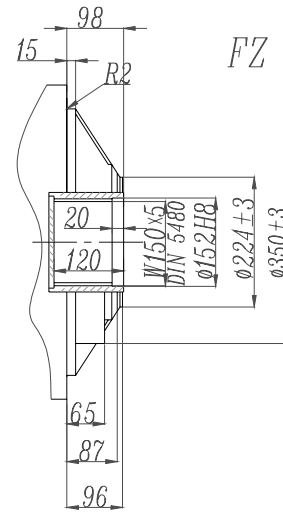
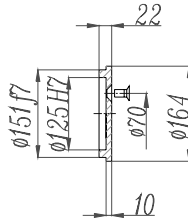
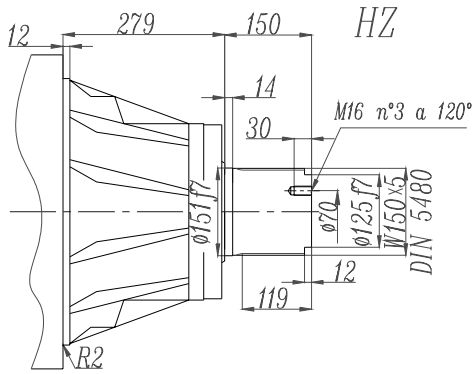
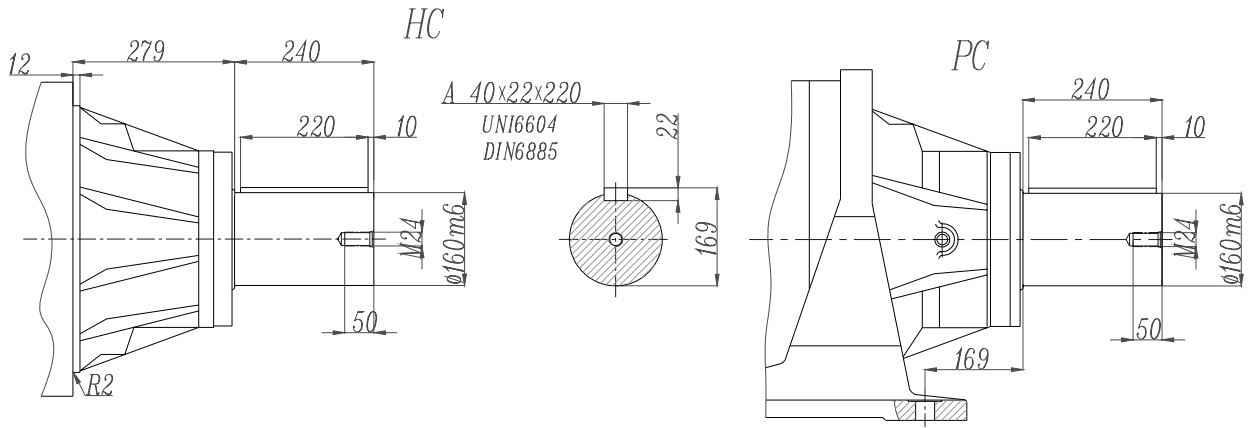

FP version

Max. transmissible

126000 N.m

EP315 L - EP315 R

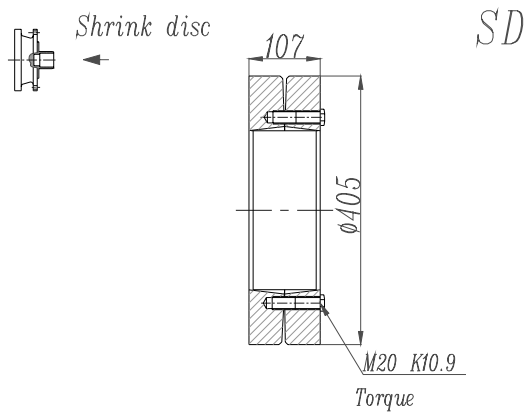
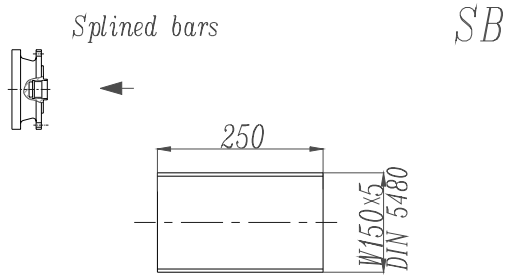
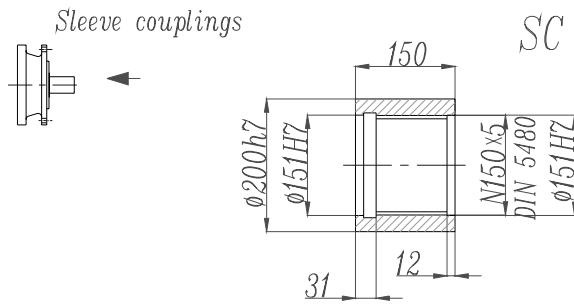
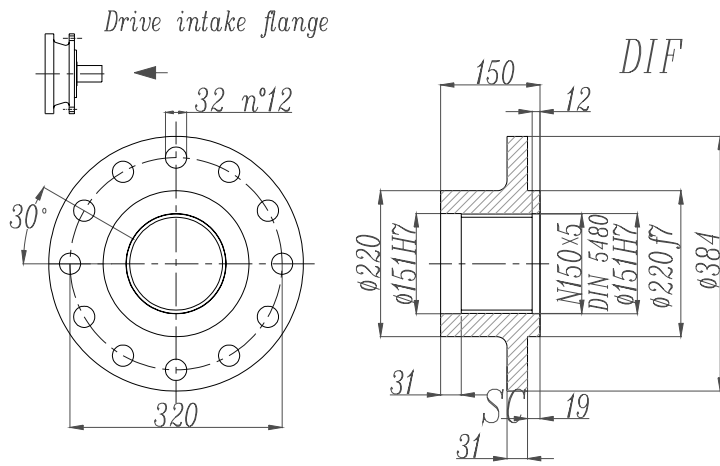

EP315 L - EP315 R

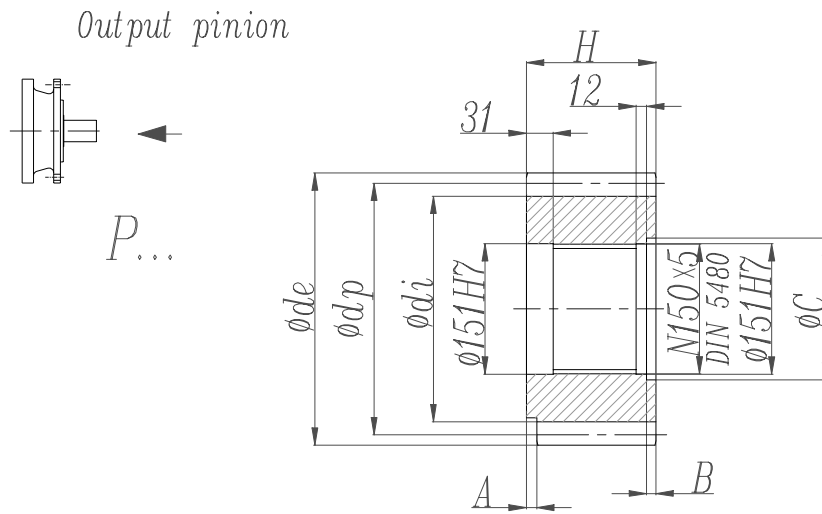

	m	z	x	dp	di	de	H	A	B	C
PRG1	18	16	0.500	288	261	342	160	0	10	166
PRG2	18	16	0.617	288	271	339	150	30	0	0

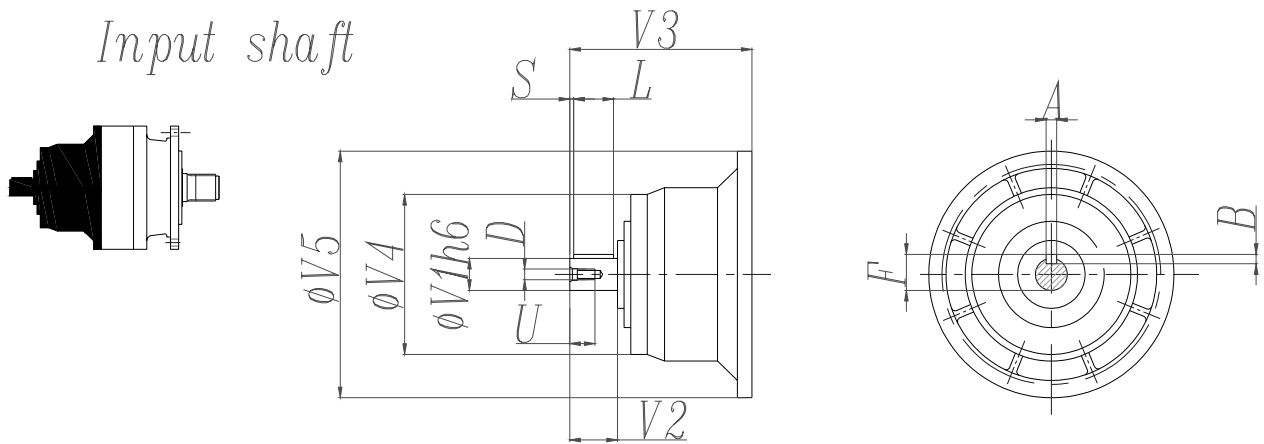

	CODE	V1	V2	V3	V4	V5	A	B	F	L	S	D	U
315 L2	V11B	80	130	348	200	428	22	14	85	110	10	M16	36
315 L3	V07B	80	130	315	200	345	22	14	85	110	105	M16	36
	V07A	60	105	315	155	345	18	11	64	90	7.5	M16	36
315 L4	V05B	48	82	239	155	245	14	9	51.5	70	6	M16	36
315 R3	V06B	60	105	307	155	292	18	11	64	90	7.5	M16	36
315 R4	V05B	48	82	239	155	245	14	9	51.5	70	6	M16	36

EP315 L - EP315 R

Permissible radial and axial loads on output shaft with Fh2 ($n_2 \cdot h=10\ 000$)

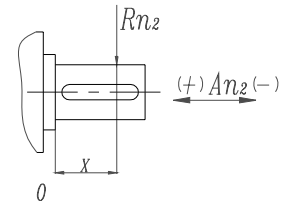
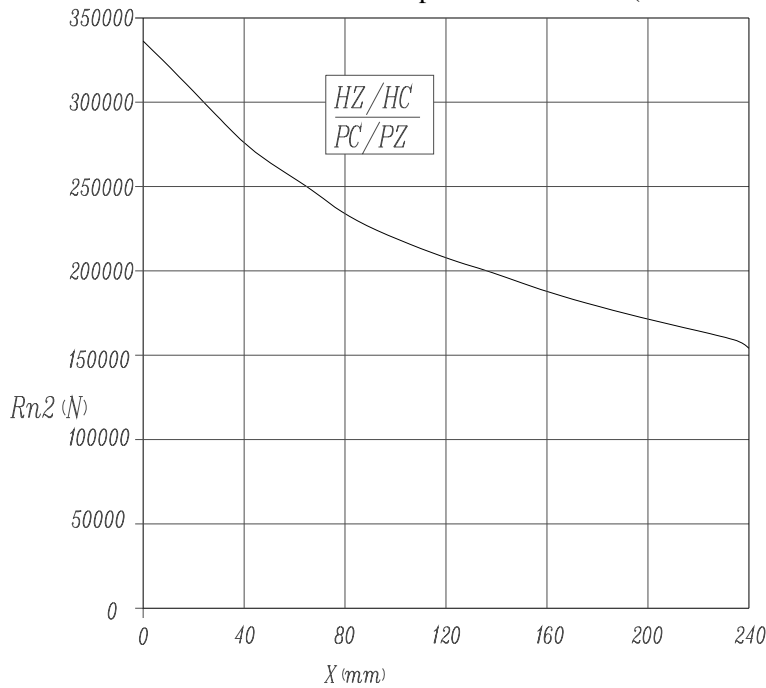

	$An_2(+)$	$An_2(-)$
HZ-HC-PC-PZ	280 000	210 000

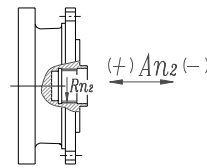

	Rn_2	$An_2(+/-)$
FZ	90 000	90 000

Load corrective factor fh2 on shafts	fh2= $n_2 \cdot h$		10 000	25 000	50 000	100 000	500 000	1 000 000
	fh2							
	MZ-MC-PC-PZ-FZ		1	0.74	0.58	0.46	0.27	0.21
	HZ-HC		1	0.76	0.61	0.50	0.31	0.25

Permissible radial loads on input shaft with Fh1 ($n_1 \cdot h=250\ 000$)

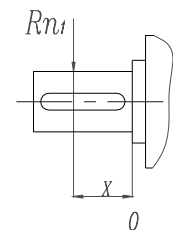
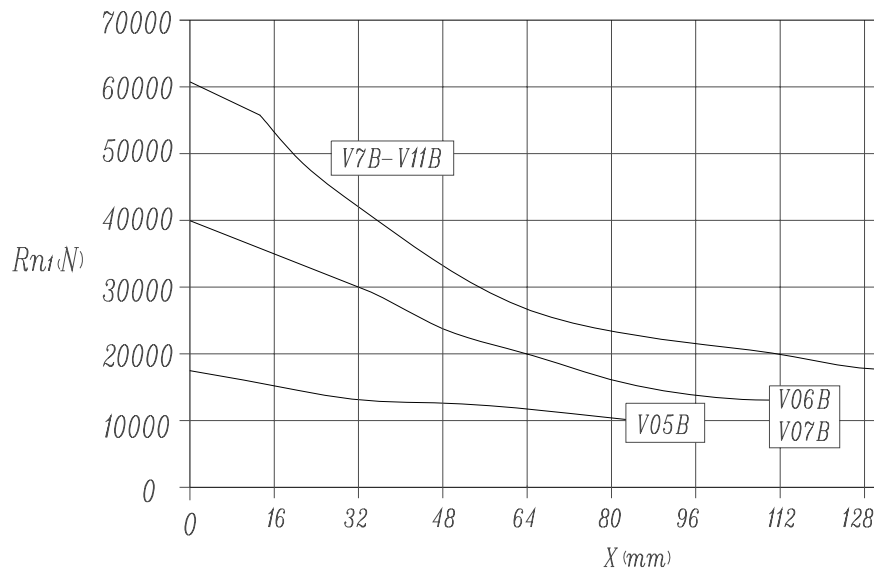

Load corrective factor fh1 on shafts	Fh1= $n_1 \cdot h$		250 000	500 000	1 000 000	2 00 000	5 000 000	10 000 000
	fh1							
	fh1		1	0.79	0.63	0.50	0.37	0.29

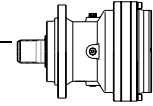

EP316L

M2'=110000N.m

	I	Mn ₂ (N.m)						P ₁ (KW)	P _t (KW) (ta=20°C) (n ₁ =1500)	n ₁ (min ⁻¹)	n _{1max} (min ⁻¹)	M _b (N.m)	Brake type
		n _{2.h} 10000	n _{2.h} 25000	n _{2.h} 50000	n _{2.h} 100000	n _{2.h} 500000	n _{2.h} 1000000						
L1	4.4	135000	126000	113000	100000	66000	54000	280	68	350	500		
	5.3	130000	120000	110000	95000	60000	50000	280	68	350	500		
L2	18.0	135000	126000	113000	100000	66000	54000	180	50	750	1000		
	23.1	135000	126000	113000	100000	66000	54000	180	50	750	1000		
	27.6	130000	120000	110000	95000	60000	50000	180	50	750	1000		
	32.7	130000	120000	110000	95000	60000	50000	180	50	750	1000		
L3	61.7	135000	126000	113000	100000	66000	54000	100	30	1500	2500	3200	6L
	79.2	135000	126000	113000	100000	66000	54000	100	30	1500	2500	2600	6K
	102	135000	126000	113000	100000	66000	54000	100	30	1500	2500	2100	6G
	121	135000	126000	113000	100000	66000	54000	100	30	1500	2500	2100	6G
	144	135000	126000	113000	100000	66000	54000	90	30	1500	2500	1500	6E
	172	130000	120000	110000	95000	60000	50000	55	30	1500	2500	1100	6C
	204	130000	120000	110000	95000	60000	50000	50	30	1500	2500	1100	6C
L4	226	135000	126000	113000	100000	66000	54000	60	18	1750	3 500	800	5G
	290	135000	126000	113000	100000	66000	54000	60	18	1750	3 500	800	5G
	333	135000	126000	113000	100000	66000	54000	60	18	1750	3 500	630	5E
	396	135000	126000	113000	100000	66000	54000	51	18	1750	3 500	500	5C
	427	135000	126000	113000	100000	66000	54000	47	18	1750	3 500	500	5C
	508	135000	126000	113000	100000	66000	54000	40	18	1750	3 500	400	5B
	606	135000	126000	113000	100000	66000	54000	34	18	1750	3 500	400	5B
	676	135000	126000	113000	100000	66000	54000	30	18	1750	3 500	400	5B
	827	135000	126000	113000	100000	66000	54000	25	18	1750	3 500	400	5B
	981	135000	126000	113000	100000	66000	54000	22	18	1750	3 500	400	5B
	1171	130000	120000	110000	95000	60000	50000	18	18	1750	3 500	400	5B
	1390	130000	120000	110000	95000	60000	50000	15.5	18	1750	3 500	400	5B

M_{2max}=1.2×Mn₂(n₂×h=10 000)

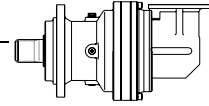

EP316R

M2'=110000N.m

	I	Mn ₂ (N.m)						P ₁ (KW)	P _t (KW) (ta=20°C) (n ₁ =1500)	n ₁ (min ⁻¹)	n _{1max} (min ⁻¹)	M _b (N.m)	Brake type
		n ₂ .h 10000	n ₂ .h 25000	n ₂ .h 50000	n ₂ .h 100000	n ₂ .h 500000	n ₂ .h 1000000						
R3	52.7	105000	79000	64000	52000	32200	26200	100	90	1500	2 500	3200	6L
	67.7	135000	12600	113000	100000	66000	54000	150	90	1500	2 500	2600	6K
	80.7	130000	12000	110000	95000	60000	50000	150	90	1500	2 500	2100	6G
	95.8	130000	12000	110000	95000	60000	50000	130	90	1500	2 500	2100	6G
R4	234	135000	12600	113000	100000	66000	54000	75	45	1750	3 500	800	5G
	300	135000	12600	113000	100000	66000	54000	60	45	1750	3 500	630	5E
	385	135000	12600	113000	100000	66000	54000	52	45	1750	3 500	500	5C
	459	135000	12600	113000	100000	66000	54000	45	45	1750	3 500	400	5B
	545	135000	12600	113000	100000	66000	54000	40	45	1750	3 500	400	5B
	650	130000	12000	110000	95000	60000	50000	33	45	1750	3 500	400	5B
	772	130000	12000	110000	95000	60000	50000	28	45	1750	3 500	400	5B

M_{2max}=1.2×Mn₂(n₂×h=10 000)

EP316 L

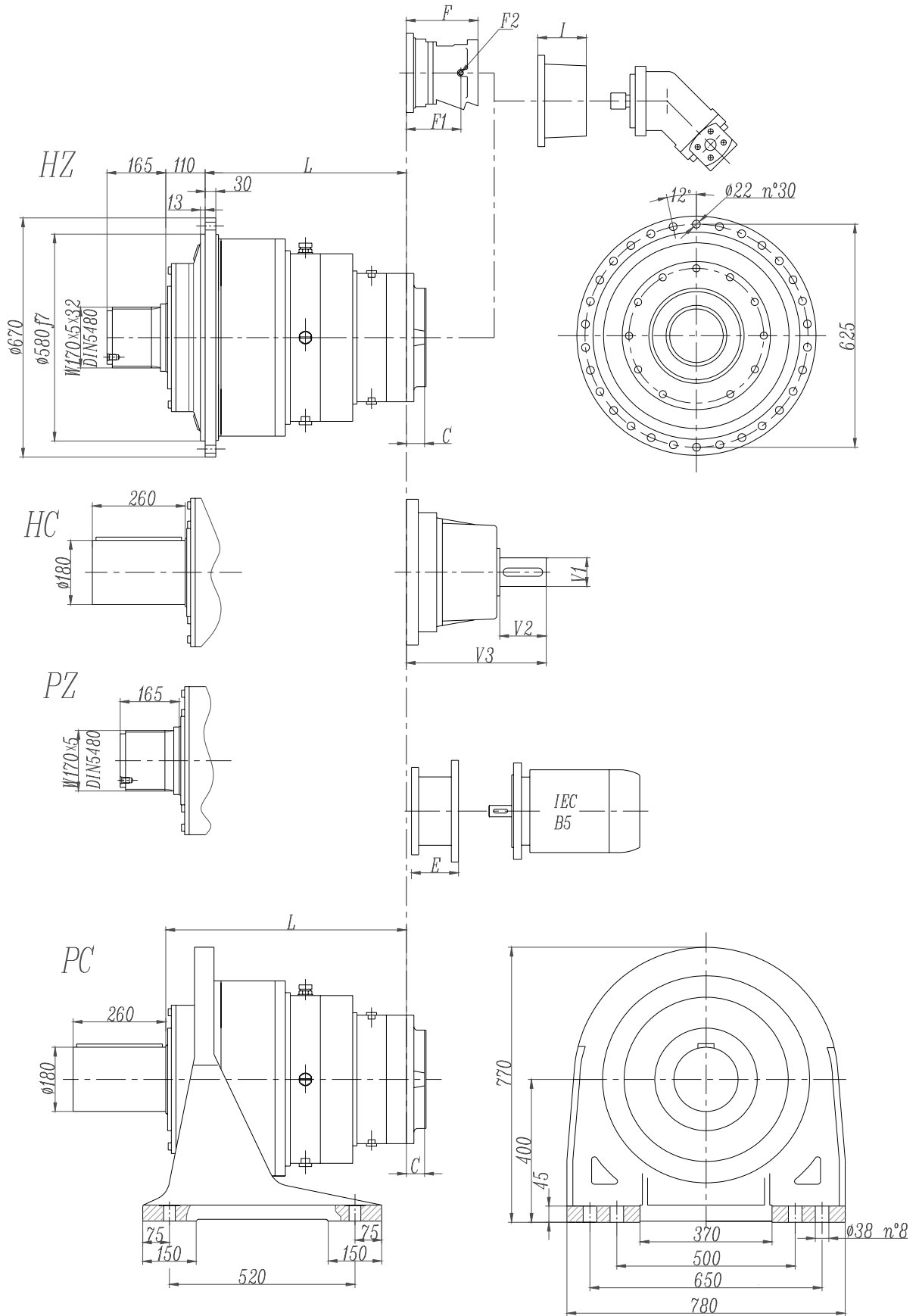

EP316 L

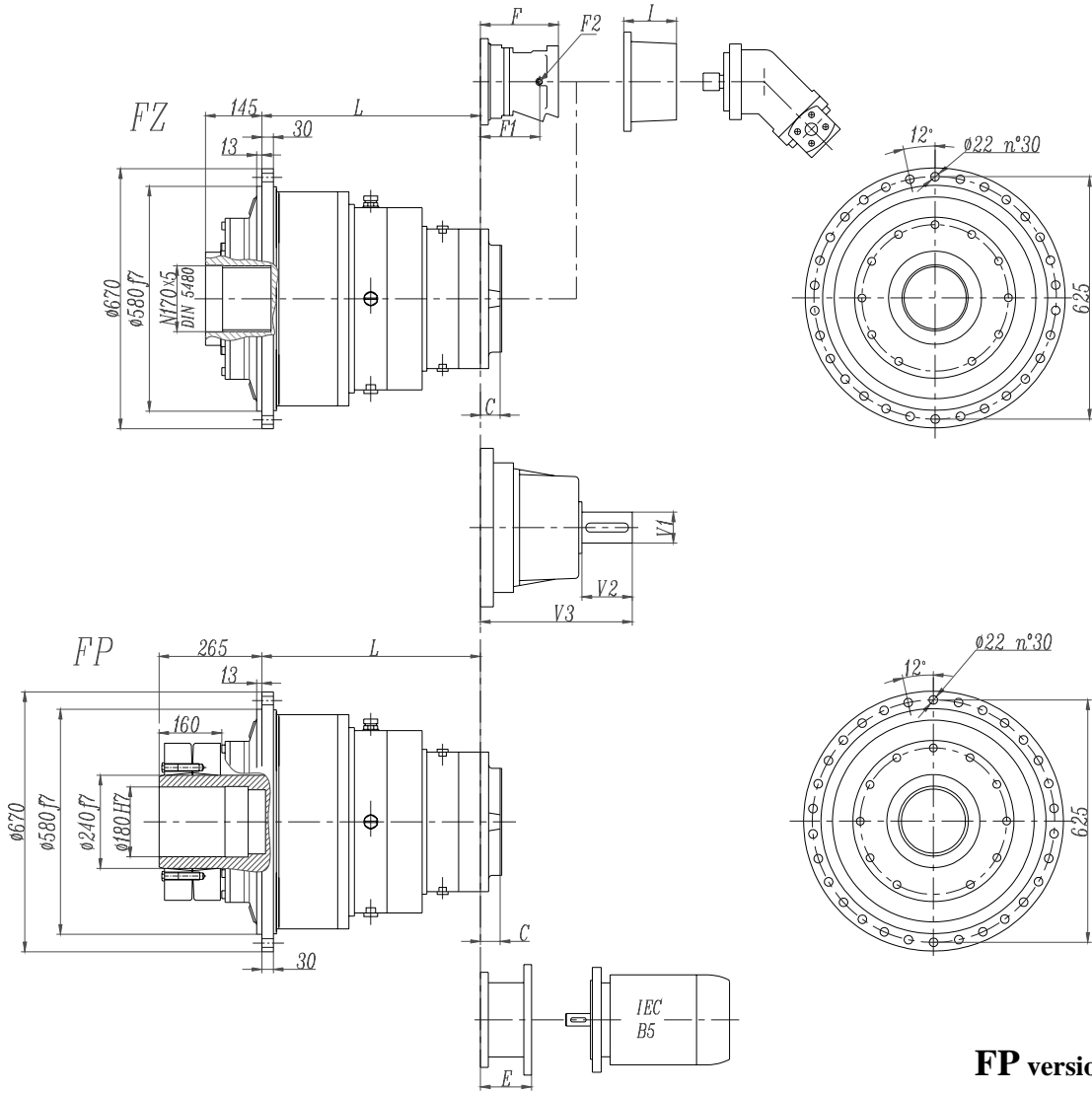

FP version
Max. transmissible
162000 N.m

	L				Ref. weight (without input) (Kg)				C	I	Brake				
	HZ HC	PC PZ	FZ	FP	HZ HC	PC PZ	FZ	FP			F	F1	F2	Type	Ref. Weight
316 L1	179	289	179	179	500	700	430	450	156	According to hydraulic motor					
316 L2	431	541	431	431	590	790	520	540	81						
316 L3	564	674	564	564	640	840	590	460	51		201	153	1/4 G	6	38 Kg
316 L4	657	767	657	657	660	860	610	472	37		145	95	1/4 G	5	22 Kg

	E (IEC motor input)												
						IEC 132	IEC 160	IEC 180	IEC 200	IEC 225	IEC 250		
316 L1													
316 L2													
316 L3								195	186	216	215		
316 L4						114	144	114	174				

EP316 R

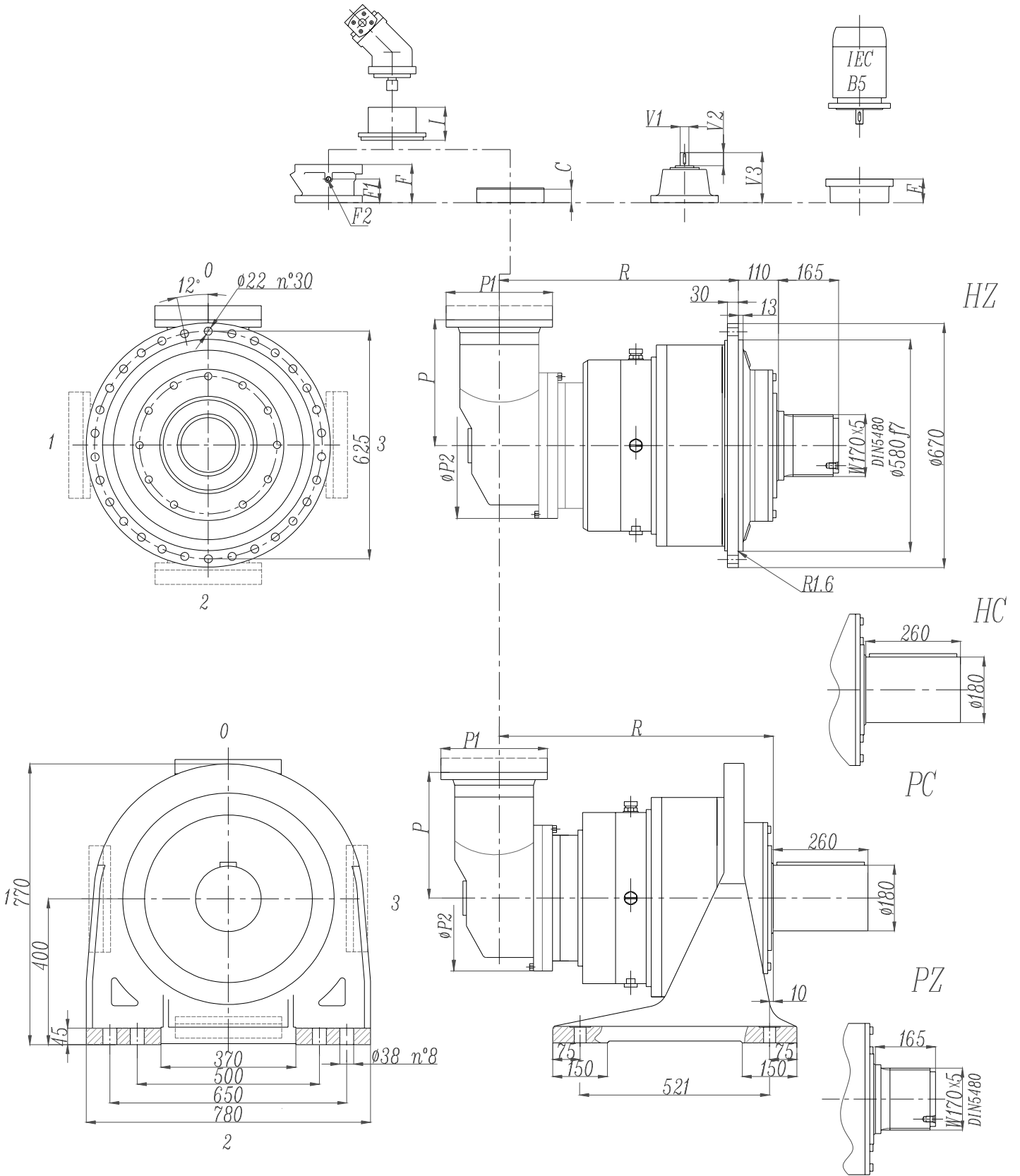

EP316 R

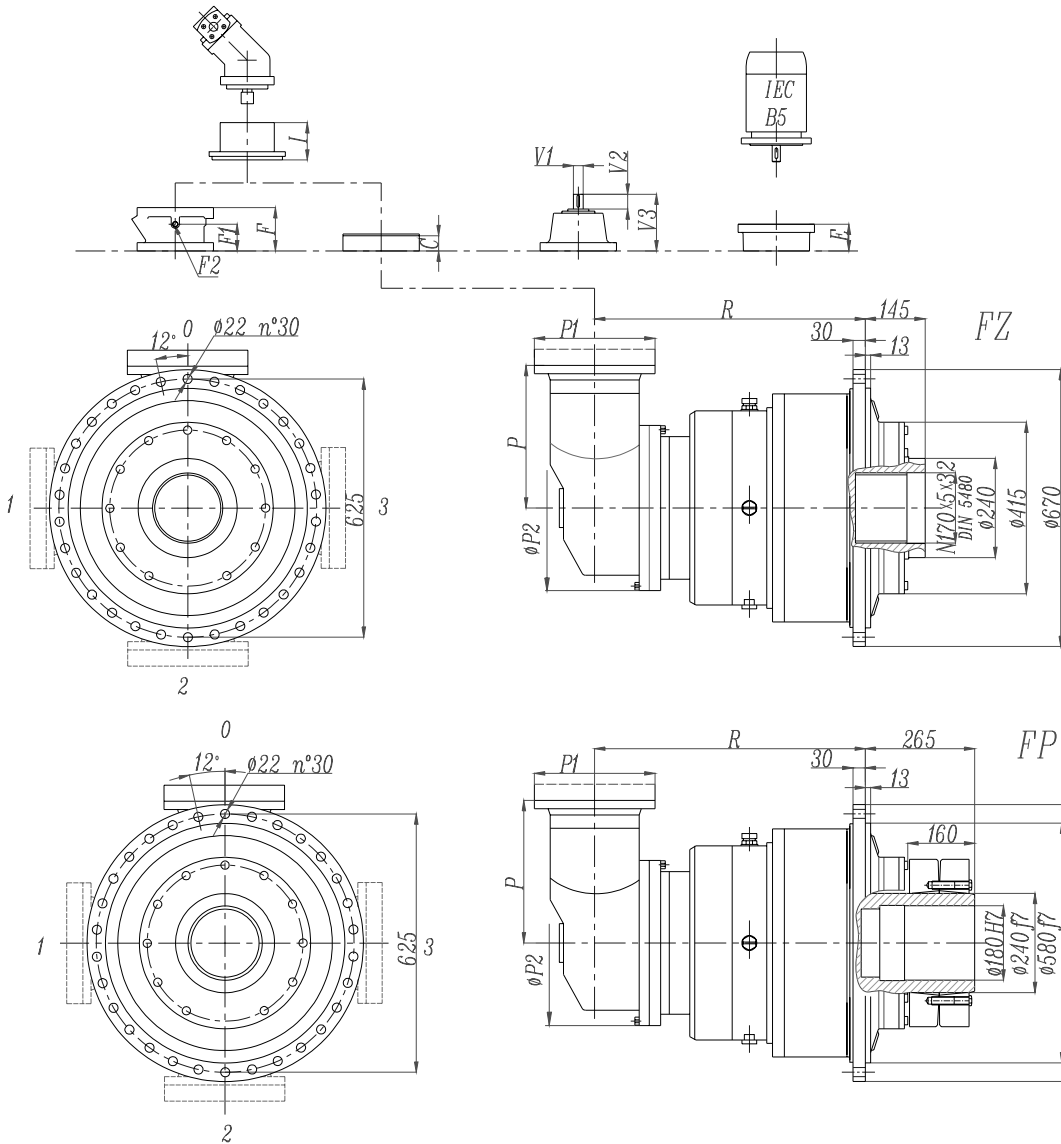

FP version
Max. transmissible
162000 N.m

	R				Ref. weight (without input) (Kg)				C	P	I	Brake				
	HZ HC	PC PZ	FZ	FP	HZ HC	PC PZ	FZ	FP				F	F1	F2	Type	Ref. Weight 15 Kg
316 R3	656	766	656	656	720	920	650	670	45	480	According to hydraulic motor	195	147	1/4 G	6	38
316 R4	687	797	687	687	690	890	620	640	37	345		145	95	1/4 G	4	22

	P1	E (IEC motor input)														
		HZ	HC	FZ	FP	IEC 71	IEC 80	IEC 90	IEC 100	IEC 112	IEC 132	IEC 160	IEC 180	IEC 200	IEC 225	IEC 250
316 R3	245	130	130	110	110								152	182	212	193
316 R4	186	130	130	110	110						114	144	144	174	174	

EP316 L - EP316 R

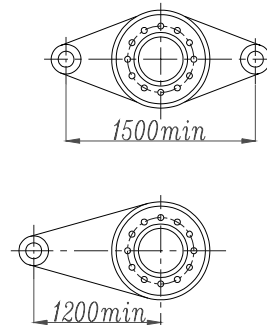
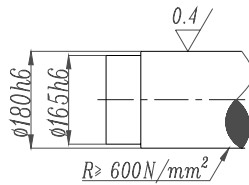
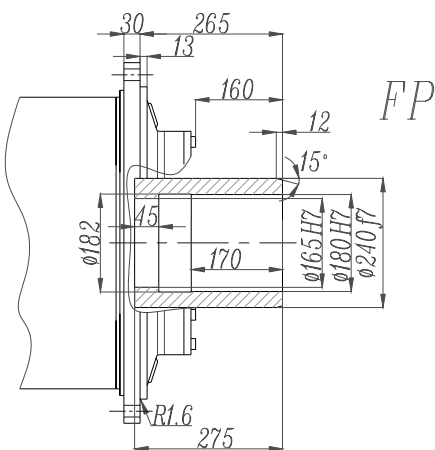
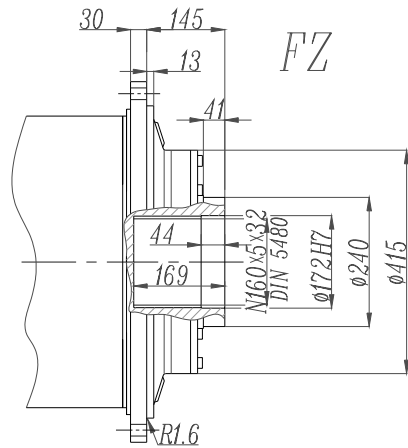
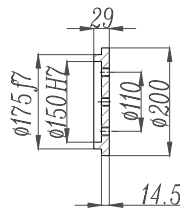
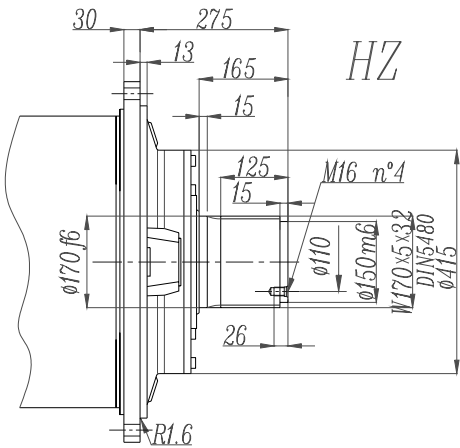
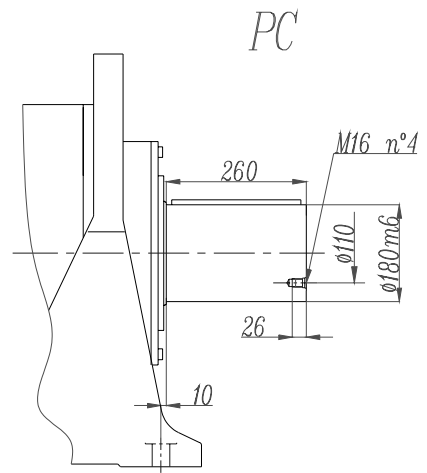
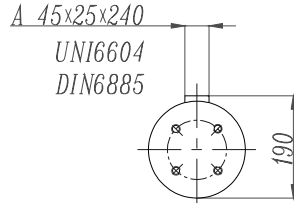
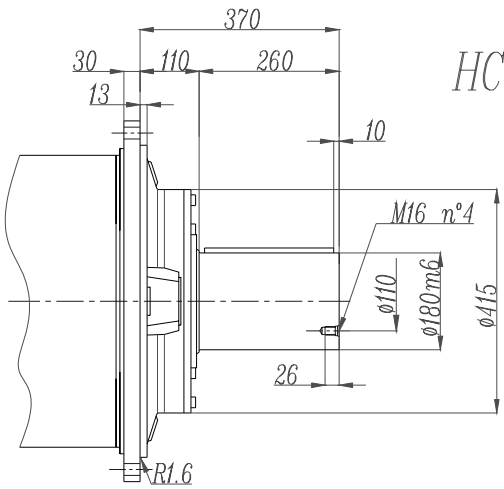

FP version

Max. transmissible

162000 N.m

EP316 L - EP316 R

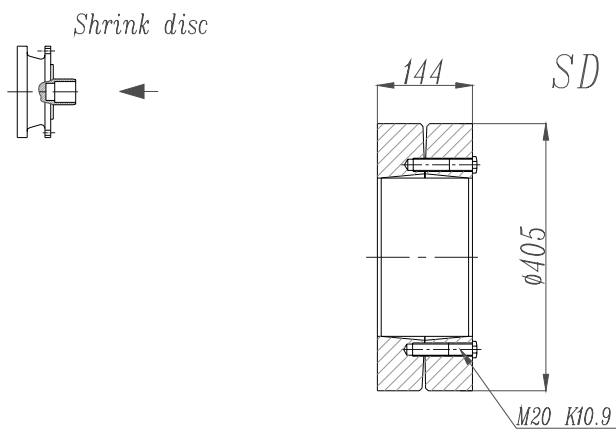
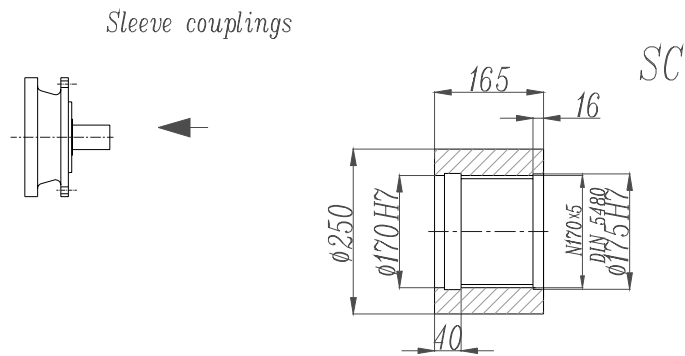
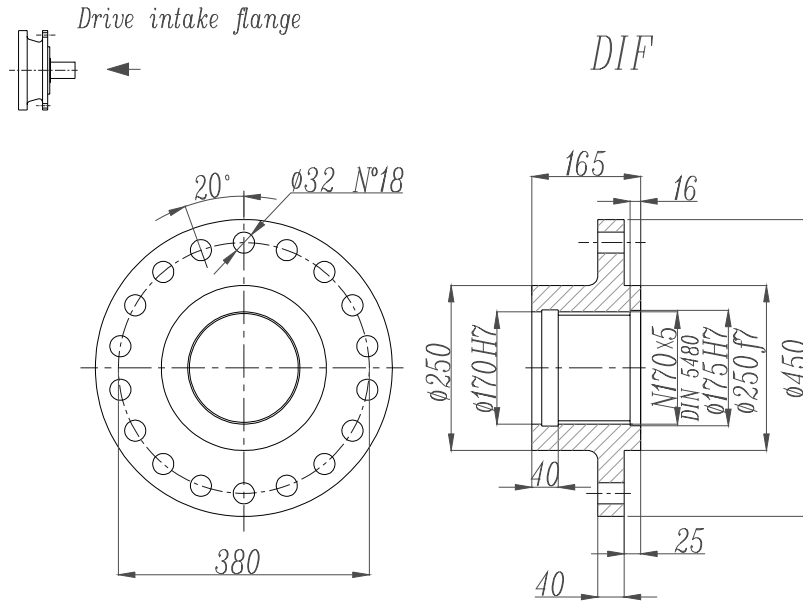

EP316 L - EP316 R

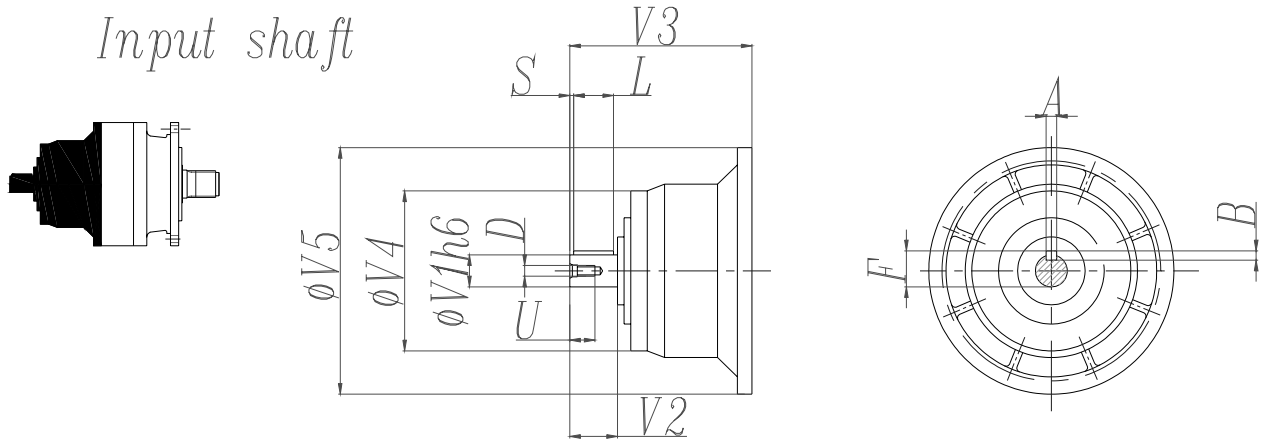

	CODE	V1	V2	V3	V4	V5	A	B	F	L	S	D	U
316 L2	V11B	80	130	348	200	428	22	14	85	110	10	M16	36
316 L3	V07B	80	130	316	200	345	22	14	85	110	105	M16	36
	V07A	60	105	316	155	345	18	11	64	90	7.5	M16	36
316 L4	V05B	48	82	239	155	245	14	9	51.5	70	6	M16	36
316 R3	V06B	60	105	307	155	292	18	11	64	90	7.5	M16	36
316 R4	V05B	48	82	239	155	245	14	9	51.5	70	6	M16	36

EP316 L - EP316 R

Permissible radial and axial loads on output shaft with Fh2 ($n_2 \cdot h=10\ 000$)

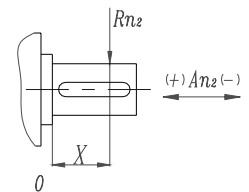
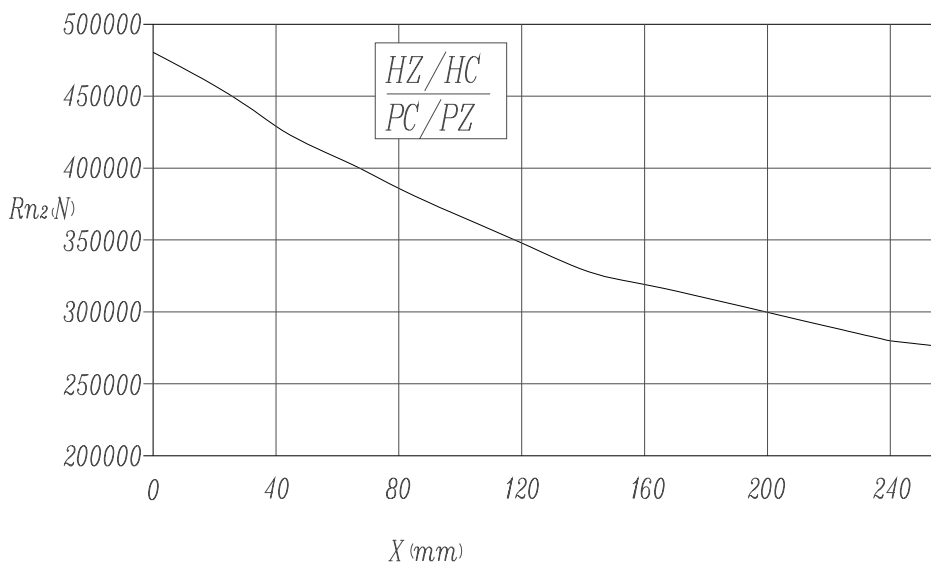

	$An_2(+)$	$An_2(-)$
HZ-HC-PC-PZ	360 000	300 000

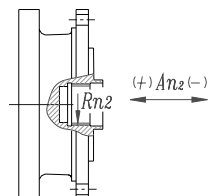

	Rn_2	$An_2(+/-)$
FZ	150 000	150 000

EP316 L - EP316 R

Load corrective factor fh2 on shafts	fh2= n2 • h		10 000	25 000	50 000	100 000	500 000	1 000 000
	fh2	MZ-MC-PC-PZ-FZ	1	0.74	0.58	0.46	0.27	0.21
		HZ-HC	1	0.76	0.61	0.50	0.31	0.25

Permissible radial loads on input shaft with Fh1 (n1 • h=250 000)

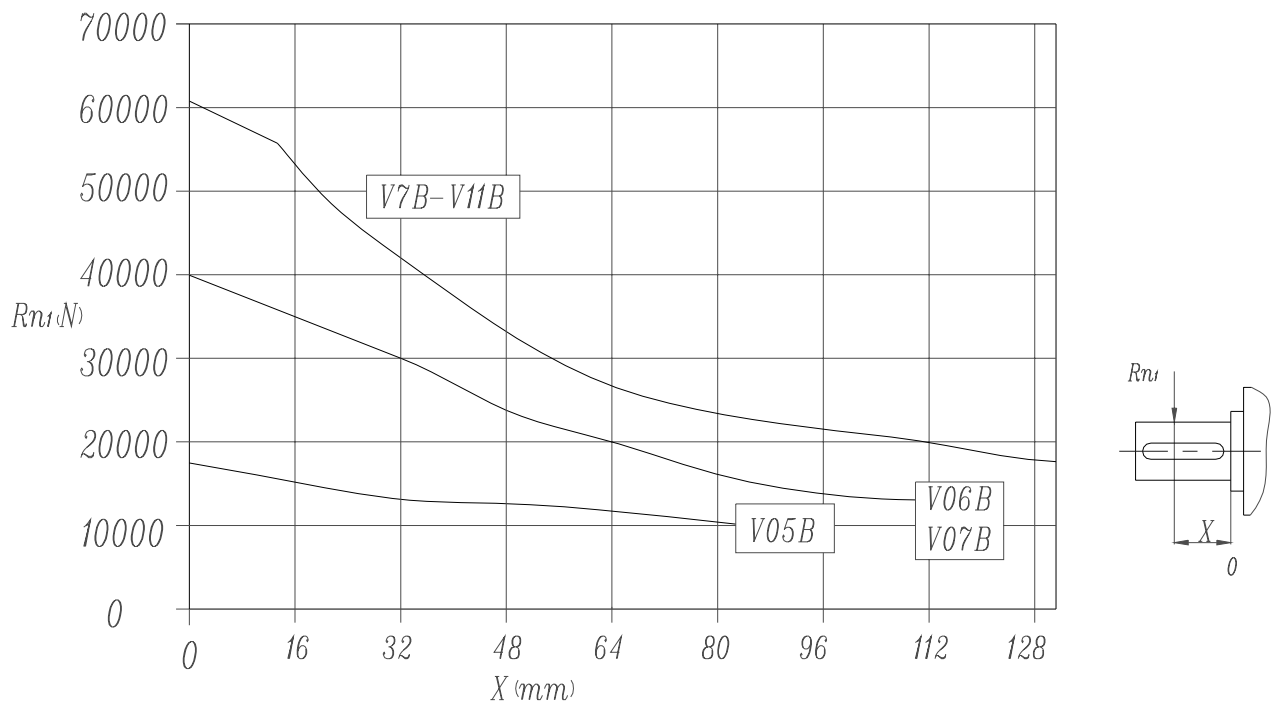

Load corrective factor fh1 on shafts	Fh1= n1 • h	250 000	500 000	1 000 000	2 00 000	5 000 000	10 000 000
	fh1		1	0.79	0.63	0.50	0.37



Parque Empresarial Cervelló
C/ Macabeo, 8
08758 Cervelló (Barcelona) Spain
Tel.: +34 93 663 07 40
Fax: +34 93 663 20 57
info@brownadvance.com
www.brownadvance.com